



Better solutions through innovation

Service Manual

Model Number:

DWOP20R

DWOP20BR

UL Part Number

6909030100

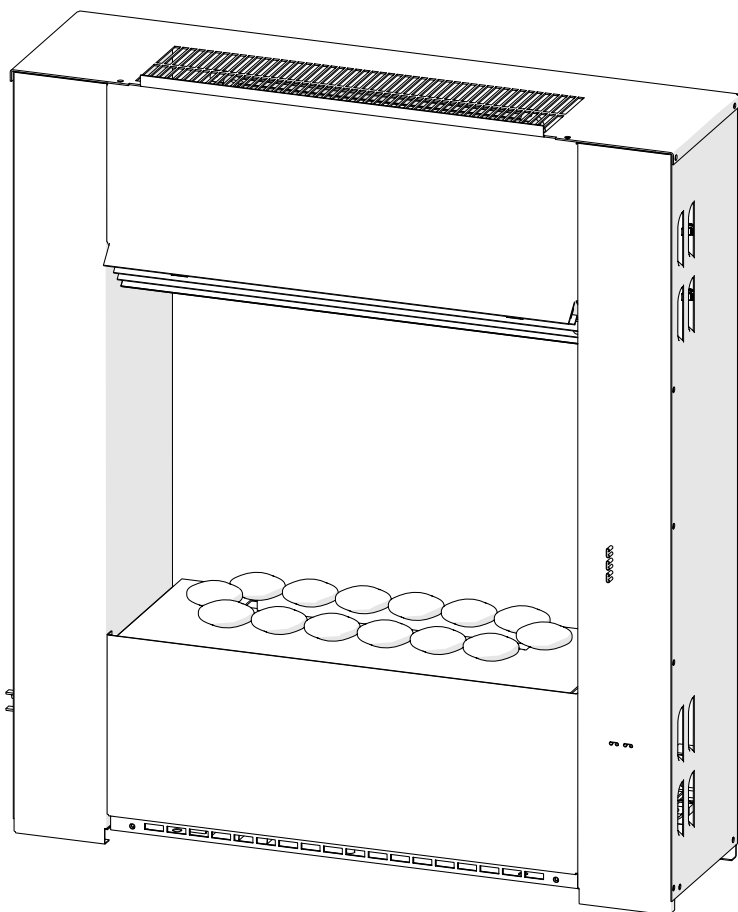

IMPORTANT SAFETY INFORMATION: Always read this manual first before attempting to service this fireplace. For your safety, always comply with all warnings and safety instructions contained in this manual to prevent personal injury or property damage.

Dimplex North America Limited
1367 Industrial Road • Cambridge ON Canada N1R 7G8
1-888-346-7539 • www.dimplex.com

In keeping with our policy of continuous product development, we reserve the right to make changes without notice.
© 2013 Dimplex North America Limited

REV	PCN	DATE
00	-	1-NOV-13

7400760100R00

TABLE OF CONTENTS

OPERATION	3
MAINTENANCE	4
EXPLODED PARTS DIAGRAM	5
REPLACEMENT PARTS	5
WIRING DIAGRAM	6
HEATER ASSEMBLY REPLACEMENT	7
COMPONENT ACCESS	7
ON/OFF SWITCH REPLACEMENT	7
3 POSITION SWITCH REPLACEMENT	8
THERMOSTAT REPLACEMENT	8
POTENTIOMETER REPLACEMENT	8
REMOTE RECEIVER REPLACEMENT	9
POWER BOARD REPLACEMENT	9
TRANSFORMER REPLACEMENT	9
IR SENSOR REPLACEMENT	9
POWER CORD REPLACEMENT	10
FAN ASSEMBLY REPLACEMENT - MOTOR AND HOUSING	10
LIGHT ASSEMBLY REPLACEMENT	10
TROUBLESHOOTING GUIDE	11

Always use a qualified technician or service agency to repair this fireplace.

! NOTE: Procedures and techniques that are considered important enough to emphasize.

⚠ CAUTION: Procedures and techniques which, if not carefully followed, will result in damage to the equipment.

⚠ WARNING: Procedures and techniques which, if not carefully followed, will expose the user to the risk of fire, serious injury, or death.

OPERATION

Figure 1

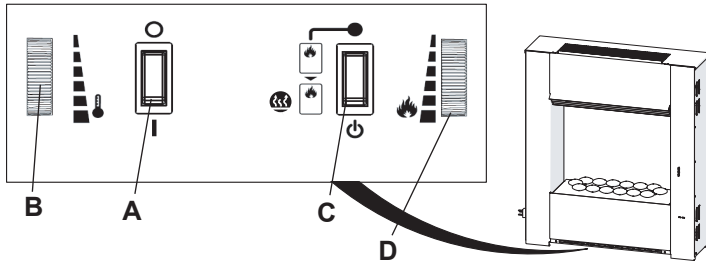

! NOTE: When the engine is used in an environment where background noise is very low, it may be possible to hear a sound which is related to the operation of the flame effect. This is normal and should not be a cause for concern.

! NOTE: Always ensure that the appliance is fixed to the wall in a level position.

The manual controls for the wall mount engine are located on the bottom of the unit. (Figure 1)

A. On/Off Switch

Supplies power to the engine.

B. Thermostat Control

To adjust the temperature to your individual requirements, turn the thermostat control backwards all the way to turn on the heater. When the room reaches the desired temperature, turn the thermostat knob forward until you hear a click. Leave thermostat in this position to maintain the room temperature at this setting. For additional heat, turn clockwise until you hear the click again and the heater will turn on.

C. Mode Selector Switch

Press once to turn on the flame effect. This will be indicated by an audible “beep”. Although the lights turn on immediately it will take 30 seconds before the flame effect starts.

- Press again to give flame effect and full heat. This will be indicated by two “beeps”.
- Press again to return to flame effect only. This will be indicated by one “beep”.
- Press  to put fire in to standby mode. This will be indicated by one “beep”.

D. Flame Intensity Control

Adjusts the intensity of the flame and smoke effect when the heater has been activated.

Turning the control knob towards you decreases the intensity of the flame and smoke effect. Turning the control knob away from you will increase the flame and smoke effect.

! NOTE: Give the flame generator some time to react to changes you may make on the flame control knob.

! NOTE: When the water tank is empty the unit will turn off after 30 seconds. See instructions under Maintenance Section for refilling tank. When this procedure is complete, the main lamps will illuminate but it will take 30 seconds before the flames return.

Resetting the Temperature Cutoff Switch

Should the heater overheat, an automatic cut out will turn the fireplace off and it will not come back on without being reset. It can be reset by switching the On/ Off Switch to Off and waiting ten (10) minutes before switching the unit back on.

! CAUTION: If you need to continuously reset the heater, unplug the unit and call Dimplex North America Limited at 1-888-346-7539 for technical support. Please have your model and serial number ready when calling.

Remote Control

The On/Off Switch must be in the ‘ON’ (I) position in order for the remote control to operate. There are 3 buttons on the remote control. (Figure 2)

! NOTE: To operate correctly the remote control must be pointed towards the heater outlet.

The remote control functions are as follows:

 Press once to turn on Flame effect only. This will be indicated by one beep.

 Press once to turn on Full heat and Flame effect. This will be indicated by two beeps.

 Standby - This will be indicated by one beep.

! NOTE: Once the mist has been activated, the unit will have to be turned Off, using either the momentary button, on the unit, or the Off button on the remote control, then back on to return to Level 1 - Logs and Light only operation.

Battery Replacement

To replace the battery:

1. Slide battery cover open on the remote control (Figure 10).
2. Install two 1.5 Volt (AAA) battery in the battery holder.
3. Close the battery cover.

 Battery must be recycled or disposed of properly. Check with your Local Authority or Retailer for recycling advice in your area.

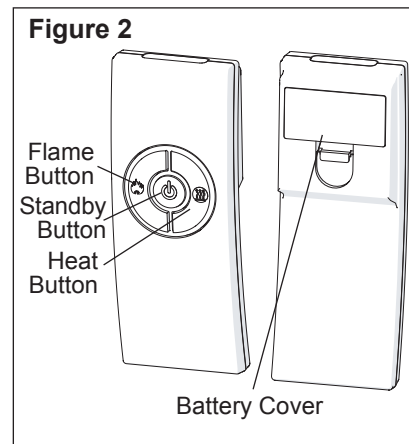

MAINTENANCE

⚠ WARNING: Disconnect power before attempting any maintenance or cleaning to reduce the risk of fire, electric shock or damage to persons.

Filling the water tank

When the water tank is empty, the flame effect shuts off and you will hear 2 audible beeps, follow these steps.

⚠ CAUTION: Allow at least five minutes for components to cool before disassembling the unit to refill.

1. Turn the On/Off switch to the off position (**0**) (Figure 1)
2. Gently remove the rock media and the media tray and place them carefully on the ground.
3. Remove the refill container by lifting upwards and outwards.
4. Refill the container with tap water.

! NOTE: Normal tap water can be used in the Optimyst® as long as the tap water is not considered to be hard water. In the event your tap water is hard, you may use softened water or distilled water with 1/8 tsp of salt (0.5 mL) added to the water reservoir. (The addition of additional salt should only be when you notice that the unit is not producing mist as expected.)

5. Screw the cap back on, **do not overtighten**.
6. Return the refill container to the sump, with the tank cap facing down and the flat side of the tank facing outward.
7. Gently place the media tray and rock media back into position.
8. Turn the On/Off switch to the off position (**I**). (Figure 1)

If you do not intend on using the unit for longer than 2 weeks, empty and drain the unit of water, and dry all of the water containing components.

Replacing the Light bulbs

If a large amount of the smoke appears grey or colourless it may be that one or more of the light bulbs have burnt out.

⚠ CAUTION: Allow at least twenty minutes for light bulbs to cool before touching bulbs to avoid accidental burning of skin.

1. Leaving the flame effect on, remove the rock media, tray and water tank and lift out the top cover (Figure 3).
2. View the lamps from a distance in front of the fire and observe which lamp needs to be changed.
3. Turn the unit off, and unplug the engine.
4. Leave the appliance for 20 minutes to allow the lamps to cool down before removing them.
5. Remove the water tank and sump (Figure 4) by lifting upwards and placing to the side.
6. Remove the defective bulb, by gently lifting vertically and disengaging the pins from the lamp holder.

! NOTE: Replacement light bulbs can be obtained by contacting Dimplex Customer Service at 1-888-346-7539.

7. Carefully insert the two pins of the new bulb into the two holes in the lamp holder. Push lamp firmly in place.
8. Replace the top cover, refill container, media tray and

media.

Cleaning

It is recommended that all of the components that contain water are cleaned with soap and water on a **biweekly** basis. A small brush has been included to assist in cleaning difficult items/areas, i.e. the transducer.

⚠ CAUTION: Do not put plastic components in the dishwasher.

Filter Cleaning

The air filter can be removed and gently rinsed with water to clean and dried on a towel before reinstalling.

! NOTE: Replace the filter so that the coarse black filter is facing the front of the engine.

Surface Cleaning

Use a warm damp cloth only to clean surfaces of the engine. Do not use abrasive cleaners.

! NOTE: If you need to move the unit ensure that all of the components that contain water have been emptied before relocating.

Figure 3

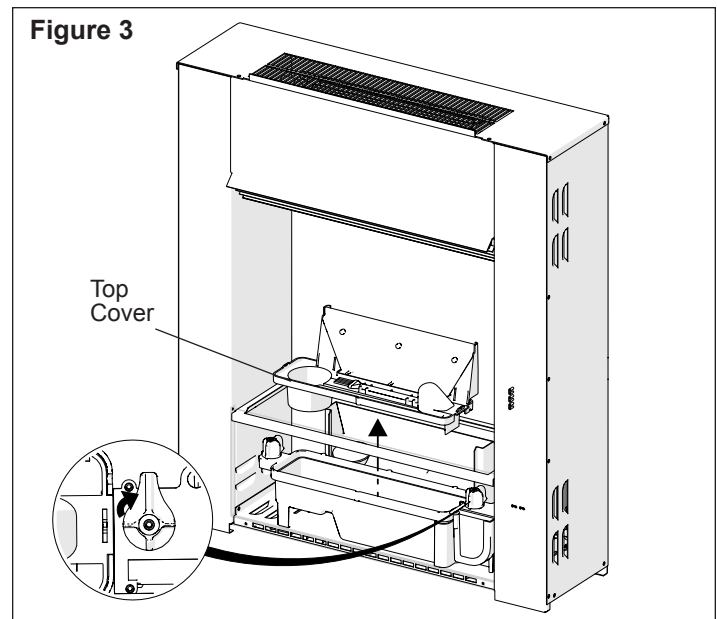
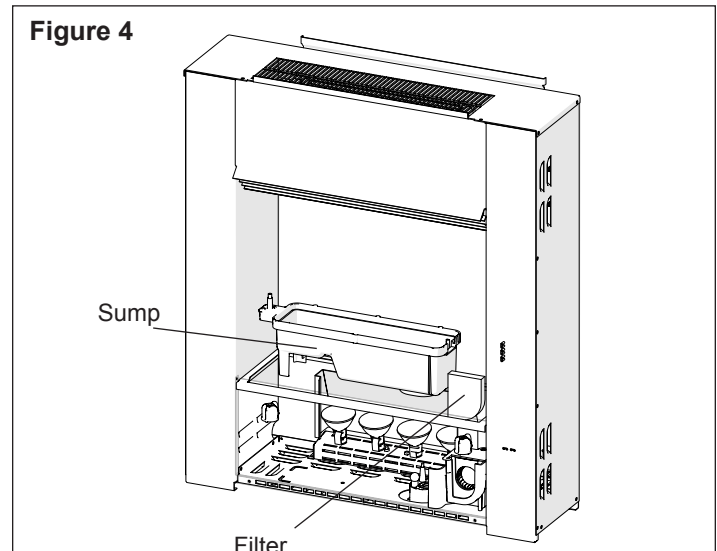
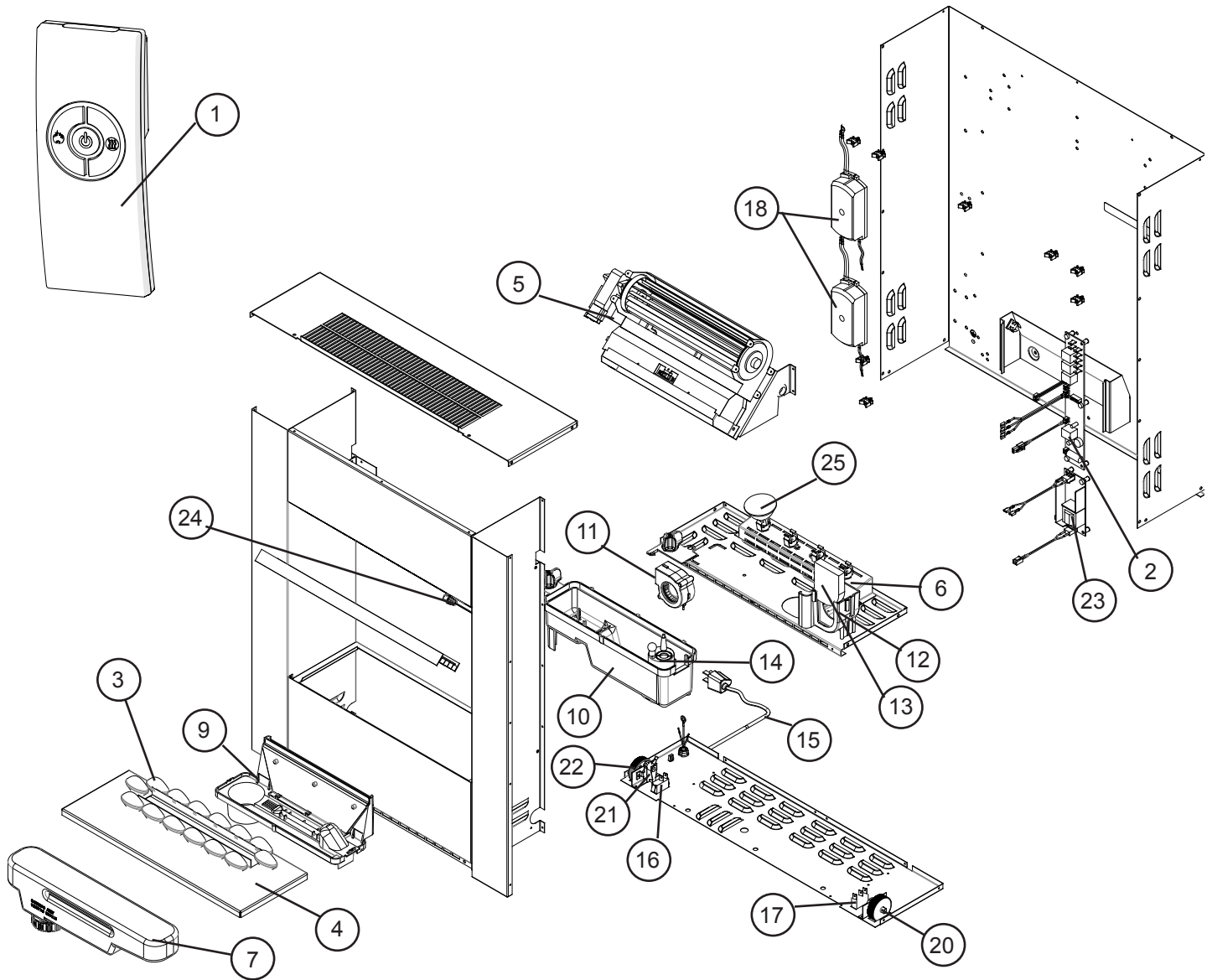

Figure 4



EXPLODED PARTS DIAGRAM



REPLACEMENT PARTS

1. Remote Control9600385600RP	14. Transducer3800040100RP
2. Remote Control Receiver9600580100RP	15. Power Cord	
3. White Rock Media9600650100RP	Mod 0-A9600385500RP
Black Rock Media6909500100RP	Mod B9600740100RP
4. Media Tray9600660100RP	16. On/Off Switch9600383500RP
5. Heating Assembly (with cutout).9600680100RP	17. 3-Position Switch9600383600RP
6. Light Holder Assembly9600610100RP	18. Transformers9600690100RP
7. Removable Refill Container with Cap	.0441440100RP	19. Mounting Hardware Kit9600700100RP
8. Cap for Refill Container0441440300RP	20. Potentiometer9600640100RP
9. Top Cover Assembly9600670100RP	21. Thermostat Assembly9600620100RP
10. Water Reservoir (Sump)0441380100RP	22. Control Knob9600630100RP
11. Fan Assembly5300300100RP	23. Power Board9600590100RP
12. Fan Housing Assembly9600540100RP	24. IR Receiver with Lens9600600100RP
13. Fan Filter8600300100RP	25. Light Bulbs	RB400

WIRING DIAGRAM

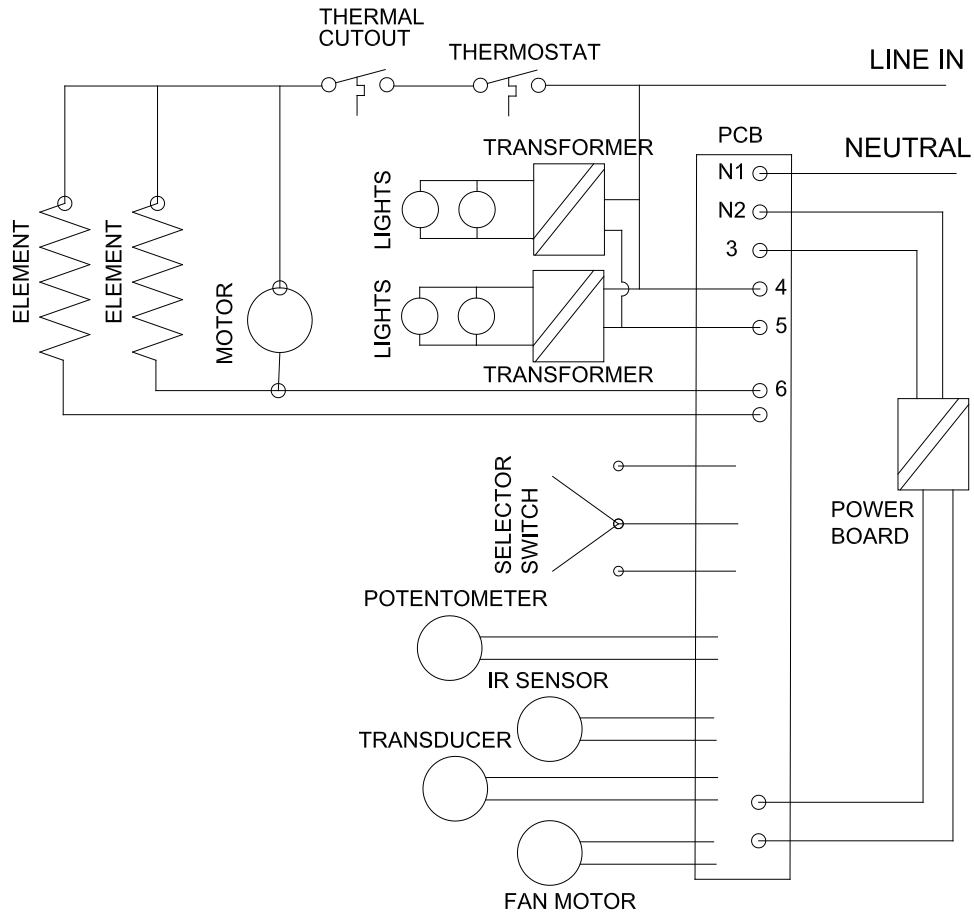

HEATER ASSEMBLY REPLACEMENT

Tools Required: Philips head screwdriver
Flat head screwdriver

⚠ WARNING: If the fireplace was operating prior to servicing, allow at least 10 minutes for light bulbs and heating elements to cool off to avoid accidental burning of skin.

⚠ WARNING: Disconnect power before attempting any maintenance to reduce the risk of electric shock or damage to persons.

1. Carefully remove the rocks from the front tray.
2. Remove the fireplace assembly from the wall by carefully lifting it upward, releasing it from the flanges of the wall-mounting bracket.
3. Carefully set the unit upright on a flat working surface.

! NOTE: If necessary, lay a protective barrier between the unit and your work surface, (i.e. cloth, cardboard, thick plastic) to avoid scratching your work surface.

4. Remove the three screws along the back edge of the top of the unit and the two screws along the top of the side edge. (Figure 5)
5. Gently remove the top panel, laying it on the work surface so that all of the components can easily be seen.
6. Remove the 4 screws that secure the heater assembly to the back panel. (Figure 6)
7. Disconnect the wiring connections noting their original locations.

! NOTE: A flat head screwdriver can be used to gently pry between the end of the connector and the switch to release the wires.

8. Transfer the mounting brackets from the old heater assembly to the new heater assembly.
9. Properly orient and install the new assembly and connect all of the wiring.
10. Reassemble in the reverse order as above.

Figure 5

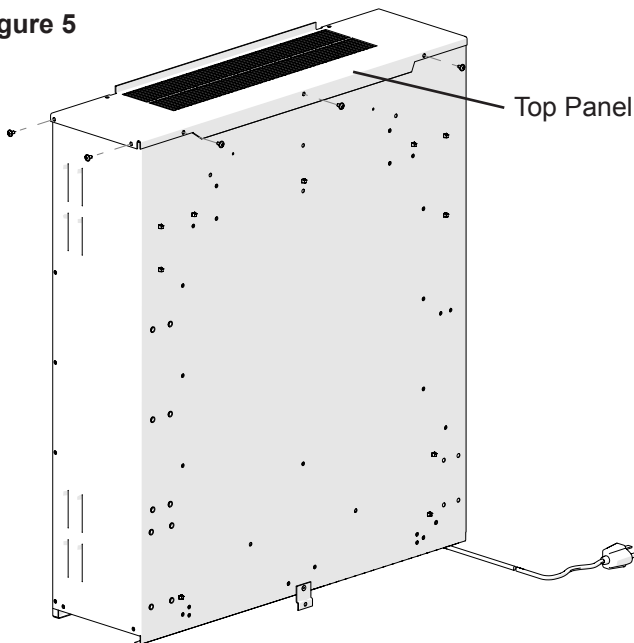
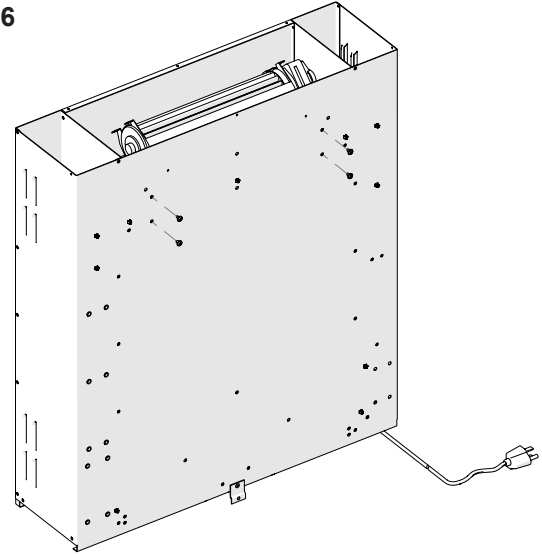

Figure 6



COMPONENT ACCESS

Tools Required: Phillips Head Screwdriver

⚠ WARNING: If the fireplace was operating prior to servicing, allow at least 10 minutes for light bulbs and heating elements to cool off to avoid accidental burning of skin.

⚠ WARNING: Disconnect power before attempting any maintenance to reduce the risk of electric shock or damage to persons.

1. Carefully remove the rocks from the front tray.
2. Remove the fireplace assembly from the wall by carefully lifting it upward, releasing it from the flanges of the wall-mounting bracket.
3. Carefully set the unit upright on a flat working surface.

! NOTE: If necessary, lay a protective barrier between the unit and your work surface, (i.e. cloth, cardboard, thick plastic) to avoid scratching your work surface.

4. Remove the three screws along the back edge of the top of the unit and the two screws along the top of the side edge. (Figure 5)
5. Gently remove the top panel, laying it on the work surface so that all of the components can easily be seen.
6. Remove the 4 screws along the front and back edge of the unit on both sides and the three along either side of the middle back of the unit. (Figure 7)
7. Lay the unit carefully down on the back surface.
8. From this point the entire front (sides and top) can be lifted off of the back exposing all of the inner components.

ON/OFF SWITCH REPLACEMENT

Tools Required: Philips head screwdriver
Flat head screwdriver

⚠ WARNING: If the fireplace was operating prior to servicing, allow at least 10 minutes for light bulbs and heating elements to cool off to avoid accidental burning of skin.

⚠ WARNING: Disconnect power before attempting any

Figure 7

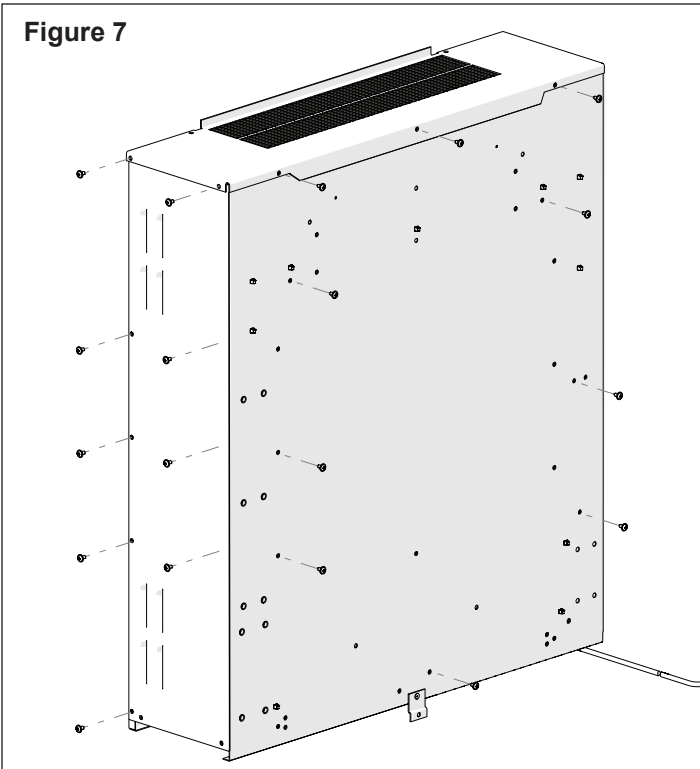

maintenance to reduce the risk of electric shock or damage to persons.

1. Follow “Component Access” instructions before proceeding.
2. Locate the On/Off switch and disconnect the wiring connections noting their original locations. (Figure 8)

! NOTE: A flat head screwdriver can be used to gently pry between the end of the connector and the switch to release the wires.

3. Depress the retainer clips on the rear of the switch and push the switch out through the opening.
4. Properly orient and insert the new switch and connect all of the wiring.
5. Reassemble in the reverse order as above.

3 POSITION SWITCH REPLACEMENT

Tools Required: Philips head screwdriver
Flat head screwdriver

⚠ WARNING: If the fireplace was operating prior to servicing, allow at least 10 minutes for light bulbs and heating elements to cool off to avoid accidental burning of skin.

⚠ WARNING: Disconnect power before attempting any maintenance to reduce the risk of electric shock or damage to persons.

1. Follow “Component Access” instructions before proceeding.
2. Locate the 3 Position switch and disconnect the wiring connections noting their original locations. (Figure 8)

! NOTE: A flat head screwdriver can be used to gently pry between the end of the connector and the switch to release the wires.

3. Depress the retainer clips on the rear of the switch and push the switch out through the opening.
4. Properly orient and insert the new switch and connect all of the wiring.
5. Reassemble in the reverse order as above.

THERMOSTAT REPLACEMENT

Tools Required: Philips head screwdriver
Flat head screwdriver

⚠ WARNING: If the fireplace was operating prior to servicing, allow at least 10 minutes for light bulbs and heating elements to cool off to avoid accidental burning of skin.

⚠ WARNING: Disconnect power before attempting any maintenance to reduce the risk of electric shock or damage to persons.

1. Follow “Component Access” instructions before proceeding.
2. Locate the thermostat and disconnect the wiring connections noting their original locations. (Figure 8)

! NOTE: A flat head screwdriver can be used to gently pry between the end of the connector and the board to release the wires.

3. Remove the screws securing the thermostat to the chassis and gently lift the thermostat off.
4. Properly orient and install the new thermostat and connect all of the wiring.
5. Reassemble in the reverse order as above.

POTENTIOMETER REPLACEMENT

Tools Required: Philips head screwdriver
Flat head screwdriver

⚠ WARNING: If the fireplace was operating prior to servicing, allow at least 10 minutes for light bulbs and heating elements to cool off to avoid accidental burning of skin.

⚠ WARNING: Disconnect power before attempting any maintenance to reduce the risk of electric shock or damage to persons.

1. Follow “Component Access” instructions before proceeding.
2. Locate the potentiometer and disconnect the wiring connections noting their original locations. (Figure 8)

! NOTE: A flat head screwdriver can be used to gently pry between the end of the connector and the board to release the wires.

3. Remove the screws securing the potentiometer to the chassis and gently lift the potentiometer off.
4. Replace the control knob, if required.
5. Properly orient and install the new potentiometer and connect all of the wiring.
6. Reassemble in the reverse order as above.

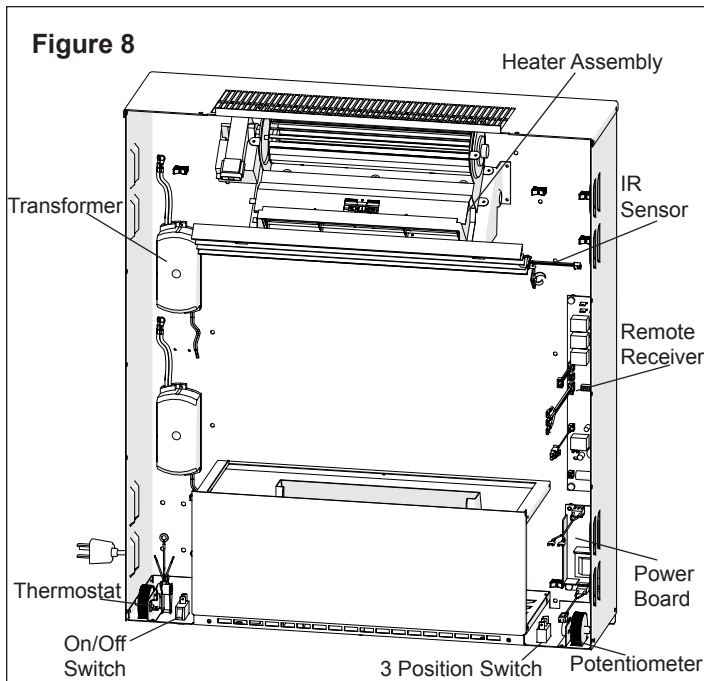

REMOTE RECEIVER REPLACEMENT

Tools Required: Philips head screwdriver
Flat head screwdriver

⚠ WARNING: If the fireplace was operating prior to servicing, allow at least 10 minutes for light bulbs and heating elements to cool off to avoid accidental burning of skin.

⚠ WARNING: Disconnect power before attempting any maintenance to reduce the risk of electric shock or damage to persons.

1. Follow "Component Access" instructions before proceeding.
2. Locate the remote control receiver and disconnect the wiring connections noting their original locations. (Figure 8)

! NOTE: A flat head screwdriver can be used to gently pry between the end of the connector and the board to release the wires.

3. Remove the screws securing the remote receiver to the chassis and gently lift the receiver off.
4. Properly orient and install the new remote control receiver and connect all of the wiring.
5. Reassemble in the reverse order as above.

POWER BOARD REPLACEMENT

Tools Required: Philips head screwdriver
Flat head screwdriver

⚠ WARNING: If the fireplace was operating prior to servicing, allow at least 10 minutes for light bulbs and heating elements to cool off to avoid accidental burning of skin.

⚠ WARNING: Disconnect power before attempting any maintenance to reduce the risk of electric shock or damage to persons.

1. Follow "Component Access" instructions before proceeding.

ceeding.

2. Locate the power board and disconnect the wiring connections noting their original locations. (Figure 8)

! NOTE: A flat head screwdriver can be used to gently pry between the end of the connector and the board to release the wires.

3. Release the power board from the chassis by using needle nose pliers to depress the tab on the mounting standoffs and gently lift the receiver off.
4. Properly orient and install the new power board and connect all of the wiring.
5. Reassemble in the reverse order as above.

TRANSFORMER REPLACEMENT

Tools Required: Philips head screwdriver
Flat head screwdriver

⚠ WARNING: If the fireplace was operating prior to servicing, allow at least 10 minutes for light bulbs and heating elements to cool off to avoid accidental burning of skin.

⚠ WARNING: Disconnect power before attempting any maintenance to reduce the risk of electric shock or damage to persons.

1. Follow "Component Access" instructions before proceeding.
2. Locate the transformer and disconnect the wiring connections noting their original locations. (Figure 8)

! NOTE: A flat head screwdriver can be used to gently pry between the end of the connector and the board to release the wires.

3. Remove the screws securing the transformer to the chassis and gently lift the board off.
4. Properly orient and install the new transformer and connect all of the wiring.
5. Reassemble in the reverse order as above.

IR SENSOR REPLACEMENT

Tools Required: Philips head screwdriver
Flat head screwdriver

⚠ WARNING: If the fireplace was operating prior to servicing, allow at least 10 minutes for light bulbs and heating elements to cool off to avoid accidental burning of skin.

⚠ WARNING: Disconnect power before attempting any maintenance to reduce the risk of electric shock or damage to persons.

1. Follow "Component Access" instructions before proceeding.
2. Locate the IR sensor and disconnect the wiring connection noting their original locations. (Figure 8)
3. Properly orient and install the new IR sensor and connect the wiring.
4. Reassemble in the reverse order as above.

Figure 9

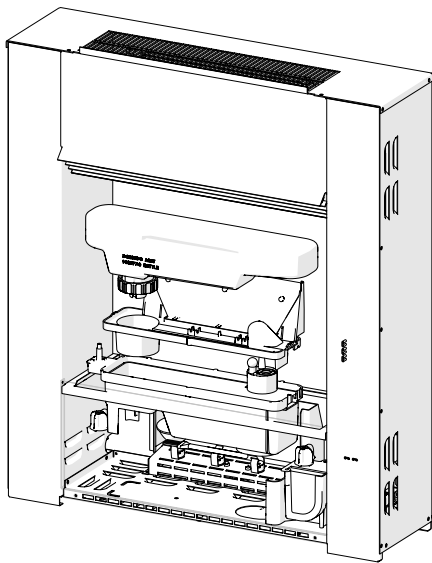

POWER CORD REPLACEMENT

Tools Required: Philips head screwdriver
Flat head screwdriver
Needle nose pliers

⚠ WARNING: If the fireplace was operating prior to servicing, allow at least 10 minutes for light bulbs and heating elements to cool off to avoid accidental burning of skin.

⚠ WARNING: Disconnect power before attempting any maintenance to reduce the risk of electric shock or damage to persons.

1. Follow “Component Access” instructions before proceeding.
2. Locate the power cord and disconnect the wiring connections noting their original locations.
! NOTE: A flat head screwdriver can be used to gently pry between the end of the connector and the switch to release the wires.
3. With needle nose pliers, grasp the power cord strain relief grommet from inside the back of the bottom panel and push while twisting to remove.
4. Install the new power cord.
5. Reassemble in the reverse order as above.

FAN ASSEMBLY REPLACEMENT - MOTOR AND HOUSING

Tools Required: Philips head screwdriver
Flat Head Screwdriver

⚠ WARNING: Disconnect power before attempting any maintenance to reduce the risk of electric shock or damage to persons.

! NOTE: Ensure that all of the components that contain water have been emptied before performing any maintenance.

1. Carefully remove the rocks from the front tray.
2. Remove the fireplace assembly from the wall by care-

fully lifting it upward, releasing it from the flanges of the wall-mounting bracket.

3. Carefully set the unit upright on a flat working surface.
! NOTE: If necessary, lay a protective barrier between the unit and your work surface, (i.e. cloth, cardboard, thick plastic) to avoid scratching your work surface.
4. Disassemble the sump components. (Figure 9)
5. Remove the 3 screws that hold the cover onto the fan housing.
6. Remove the fan motor out of the housing and disconnect the wiring connection located near the bottom of the housing.
7. If replacing only the motor, attach new motor and reassemble the remainder of the cassette in reverse order from the instructions above.
 - If replacing the housing, remove the 3 screws attaching the base to the cassette. (Figure 6)
8. Attach new fan housing base to the cassette.
9. Transfer the filter from the old housing to the new housing.
10. Reinstall the fan motor and reconnect the wire.
11. Re-assemble the remainder of the cassette in reverse order from the instructions above.

LIGHT ASSEMBLY REPLACEMENT

Tools Required: Phillips Head Screwdriver

⚠ WARNING: If the fireplace was operating prior to servicing, allow at least 10 minutes for light bulbs and heating elements to cool off to avoid accidental burning of skin.

⚠ WARNING: Disconnect power before attempting any maintenance to reduce the risk of electric shock or damage to persons.

1. Carefully remove the rocks from the front tray.
2. Remove the fireplace assembly from the wall by carefully lifting it upward, releasing it from the flanges of the wall-mounting bracket.
3. Carefully set the unit upright on a flat working surface.
! NOTE: If necessary, lay a protective barrier between the unit and your work surface, (i.e. cloth, cardboard, thick plastic) to avoid scratching your work surface.
4. Disassemble the sump components. (Figure 9)
5. Lay the unit carefully down on the back surface.
6. Remove the light bulbs and place in a safe location.
7. Remove the two screws securing the light assembly and housing bracket to the bottom panel.
8. Lift the assembly out and disconnect the wiring connections noting their original locations.
9. Remove the light assembly from the housing bracket.
10. Properly orient and install the new light assembly and connect all of the wiring.
11. Reassemble in the reverse order as above.

TROUBLESHOOTING GUIDE

PROBLEM	CAUSE	SOLUTION
General		
Circuit breaker trips or fuse blows when unit is turned on	Short in unit wiring.	Trace wiring in unit.
	Improper circuit current rating	Additional appliances may exceed the current rating of the circuit breaker or fuse. Plug unit into another outlet or install unit on a dedicated 15 amp circuit.
Lights dim in room while the unit is on	Unit is drawing close to circuit current rating	Move the unit to another outlet or install unit on a dedicated 15 amp circuit
Power cord gets warm	Normal Operation	The power cord may get slightly warm to the touch when the heater is on
	Defective power cord	Replace power cord if cord gets hot to the touch.
Unpleasant smell when unit is used.	Dirty or stale water.	Clean the unit as described under maintenance.
Appearance		
Fireplace does not turn on Manually	Improper operation	Refer to Operation Section
	No incoming voltage from the electrical wall socket	Check Fuse/Breaker Panel
	Defective 3 Position Switch	Replace 3 Position switch
Fireplace does not turn on with the Remote Control	Improper operation	Refer to Operation Section
	The batteries in the remote control are dead.	Install new battery into the remote control
	Defective remote control	Replace Remote Control
	Defective remote control receiver	Replace remote control receive
	Defective IR sensor	Replace IR sensor
The flame effect will not start	Switch A is in the 'ON' (I) position, but mode Switch B has not been pressed. (Figure 2)	Press Switch B once for flame effect. (Figure 2)
	Low water level.	Check the water tank is full and there is water in the sump.
	Water in unit is too cold	Allow water to warm to room temperature.
	If using distilled or reverse osmosis water, unit will not produce a consistent mist	Add 1/8 tsp of table salt to water reservoir to introduce electrolytes, only repeat when mist is not being produced correctly
	Check that the fan is operating correctly	Replace fan assembly Ensure that the air filter is clean and dry
	Cord is located over emitter on transducer	Relocate cord so that mist is free to rise off of transducer.
	Defective Transducer	Replace Transducer
The flame effect is too low.	Flame effect control knob is set too low. (Figure 2)	Increase level of flame by turning Control knob C to the left slowly. (Figure 2)
The flame effect has too much smoke.	Flame effect setting is too high.	Turn the flame effect Control knob "C" to the right until it is at minimum and slowly turn to the left, about ¼ a turn, at a time. Give the flame generator some time to adjust before increasing. (Figure 2)
Mist is not coming out and the red light by the transducer is not on	The cord from the power board is not working	Ensure that the cord is not pinched.
		Ensure that the cord is fully inserted into the connection on the power board.
Mist is coming out fast	Filter is missing off of Fan Housing	Replace Fan Filter
Mist does not appear to be coming out evenly	Unit is not level	Level unit
	Media is blocking air flow	Rearrange media
	A light bulb is burnt out	Replace light bulb

PROBLEM	CAUSE	SOLUTION
Heater		
Heater is not turning off	Improper operation	Refer to Operation Section
	Defective 3 position switch	Replace 3 position switch
	Defective thermostat	Replace thermostat
Heater is not turning on	Improper operation	Refer to Operation Section
	Loose wiring	Trace Wiring
	Defective heater assembly	Replace heater assembly
	Defective 3 position switch	Replace 3 position switch
Heater is turning off after a couple of minutes of operation	Build up of dirt/dust in heater assembly	Ensure that exterior intake louvers and firebox cavity are free of dirt/dust.
	Defective Heater Assembly	Replace Heater Assembly
Heater emits an odor	Normal Operation	Normal operation is when the heater emits an odor for a brief period after the heater is initially turned on. The heater is burning off any dust accumulated during manufacturing or operation.
	Defective heater assembly	Replace heater assembly
Heater fan turns on but heater lacks heat	Improper operation	Refer to Operation Section
	Loose wiring	Trace wiring in unit
	Defective heater assembly	Replace heater assembly
Heating element is glowing red	Normal Operation	Small glowing sections of the element are considered normal.
	Defective heater assembly	If larger glowing sections are causing the heater to trip the thermal cutout, unplug unit, discontinue use and replace heater assembly.
Heater fan runs continuously	Loose wiring	Trace wiring in unit
	Defective momentary switch	Replace momentary switch
	Defective heater assembly	Replace heater assembly
Noise		
Excessive noise with the heater on	Dirty heater assembly	Ensure that exterior intake louvers and firebox cavity are free of dirt/dust.
	Defective heater assembly	Replace heater assembly