

⚠ WARNING: FIRE OR EXPLOSION HAZARD If the information in this manual is not followed exactly, a fire or explosion could result causing property damage, personal injury or death.

- Do not store or use gasoline or other flammable vapors and liquids in the vicinity of this or any other appliance.
- **WHAT TO DO IF YOU SMELL GAS:**
 - Do not try to light any appliance.
 - Do not touch any electrical switch; do not use any phone in your building.
 - Immediately call your gas supplier from a neighbor's phone. Follow the gas supplier's instructions.
 - If you cannot reach your gas supplier, call the fire department.
- Installation and service must be performed by a qualified installer, service agency or the gas supplier.

Model BW9 Gas-Fired Direct Vent Condensing Water Boiler

NOTE TO INSTALLER:

This manual must be left with the equipment user.

USER:

Please read all manuals and retain manuals for future reference.

**USER'S INFORMATION
MANUAL FOR THE
OPERATION AND
MAINTENANCE OF YOUR
NEW GAS-FIRED DIRECT
VENT CONDENSING BOILER**

**⚠ WARNING: CARBON MONOXIDE
POISONING HAZARD**

Failure to follow this warning could result in personal injury or death. Carbon Monoxide is invisible, odorless, and toxic! We recommend a carbon monoxide alarm in your home, even if you do not own a gas appliance. Locate the carbon monoxide alarm in the living area of your home and away from gas appliances and doorways to attached garages. Follow the alarm manufacturer's instructions included with the alarm.

Do not use this furnace if any part has been under water. A flood-damaged furnace is extremely dangerous. Attempts to use the furnace can result in fire or explosion. A qualified service agency should be contacted to inspect the furnace and to replace all gas controls, control system parts, electrical parts that have been wet or the furnace if deemed necessary.

Gas-Fired Direct Vent Condensing Water Boiler

Congratulations! Your new gas-fired indoor boiler is an excellent choice and sound investment in home heating comfort. Your modern boiler represents the latest in engineering development and is the culmination of many years of experience from one of the most reputable manufacturers of residential hydronic heating systems.

Not only is your new boiler one of the most energy-efficient heating systems you can buy today, it is also one of the safest and most dependable. With only minimal care, your new boiler will continue to deliver money-saving home comfort and enjoyment for many years to come. Spend just a few minutes with this manual to learn the operation of your new boiler and the small amount of maintenance it takes to help keep it operating at peak efficiency.

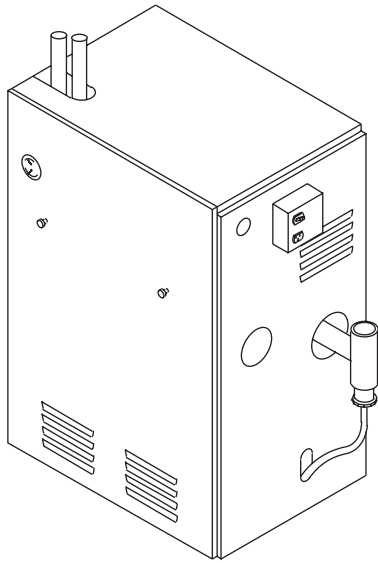

1

**Model BW9-50 Through 100
Gas-Fired Direct Vent
Condensing Water Boiler**

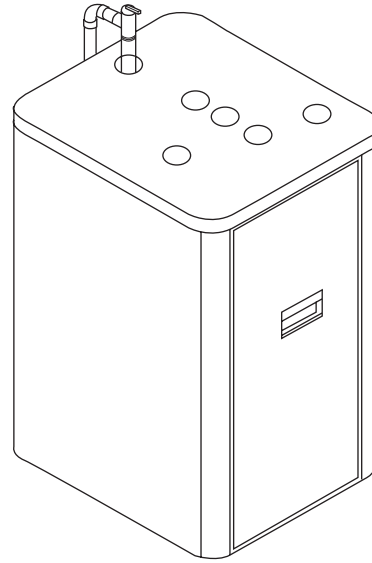

2

**Model BW9-125 Through 200
Gas-Fired Direct Vent
Condensing Water Boiler**

BOILER IDENTIFICATION

For your convenience, record the product and serial numbers of your new boiler on the form below. Should you ever require service, you will have ready access to the information needed by the service representative.

Product No. _____

Serial No. _____

Date Installed _____

Dealer Name _____

Address _____

City _____

State _____ Zip _____

Telephone _____

Typical boiler and piping arrangements are shown in Fig. 3 through 6. Since there are many variations in boiler piping systems, your system may not look the same as shown. Your dealer is your best resource to explain your particular boiler piping arrangement.

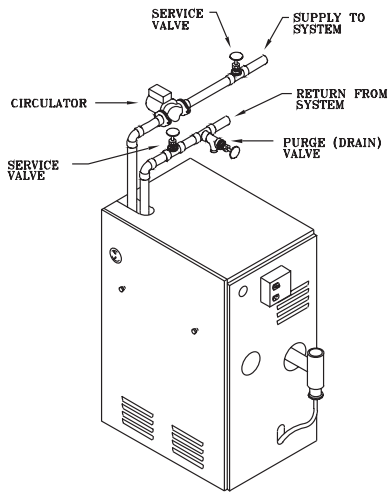

3

**BW9 050, 075, 100
Typical Single Zone Piping**

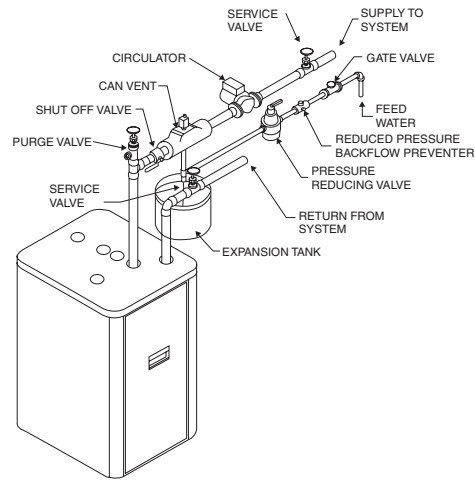

4

**BW9 125, 150, 175, 200
Typical Single Zone Piping**

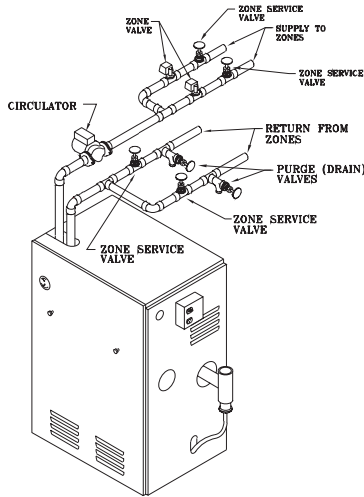

5

**BW9 050, 075, 100
Typical Multi-Zone Piping**

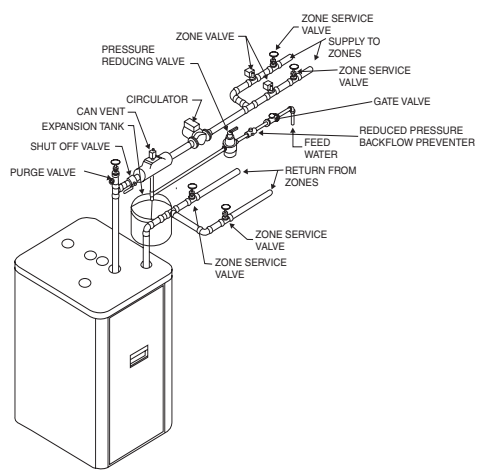

6

**BW9 125, 150, 175, 200
Typical Multi-Zone Piping**

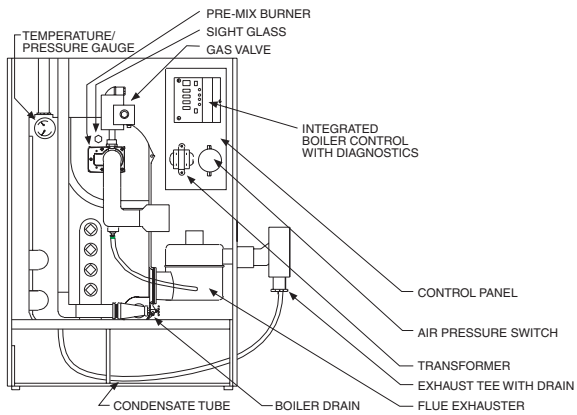

7

**BW9 050, 075, 100
Component Location**

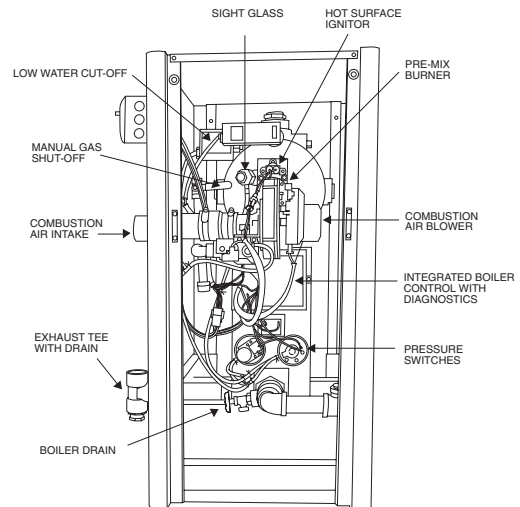

8

**BW9 125, 150, 175, 200
Component Location**

SAFETY CONSIDERATIONS

Installing and servicing heating equipment can be hazardous due to gas and electrical components. Only trained and qualified personnel should install, repair, or service heating equipment.

Untrained personnel may perform the inspections shown in this Owners Guide. All other operations must be performed by trained service personnel. Observe safety precautions in this manual, on tags, and on labels attached to the boiler, and other safety precautions that may apply.

Recognize safety information. This is the safety-alert symbol \triangle . When you see this symbol on the boiler and in instructions or manuals, be alert to the potential for personal injury.

Understand the signal words DANGER, WARNING, and CAUTION. These words are used with the safety-alert symbol. DANGER identifies the most serious hazards which **will** result in severe personal injury or death. WARNING signifies hazards which **could** result in personal injury or death. CAUTION is used to identify unsafe practices which **may** result in minor personal injury or product and property damage. NOTE is used to highlight suggestions which will result in enhanced installation, reliability or operation.

IMPORTANT FACTS ABOUT YOUR BOILER (DO'S AND DON'TS)

- DO: READ AND UNDERSTAND THIS MANUAL.
- DO: Have your boiler and vent system inspected annually by a qualified service technician.
- DO: Inspect your boiler monthly for water leaks or other obvious signs service may be required.
- DO: Provide adequate airflow to the boiler or efficient combustion and safe ventilation.
- DO: Keep your boiler free and clear of insulation material. Some materials may be combustible. Examine the boiler area when the boiler is installed or when insulation is added.
- DO NOT: Enclose your boiler in an airtight room. Allow for adequate ventilation of the boiler room or combustion air of other appliances.
- DO NOT: Keep combustible materials, gasoline, and other flammable liquids or vapors around your boiler.

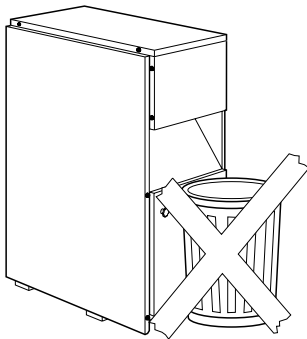

9

- DO NOT: Cover your boiler in any manner.
- DO NOT: Store anything (including trash or debris) near your boiler.
- DO NOT: In any way block or restrict airflow around your boiler.
- DO NOT: In any way block or restrict airflow to your supply air and return air grills.
- DO NOT: Use your boiler room as a broom closet or a place to store any kind of chemical or cleaner.

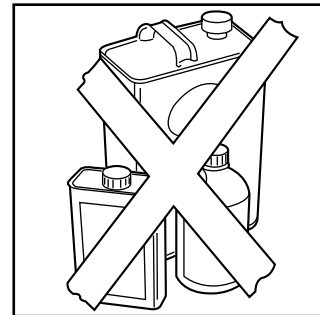

10

BEFORE STARTING YOUR BOILER

Examine the boiler installation to determine that:

1. All flue gas carrying areas external to the boiler (i.e. 2 pipe termination or concentric vent) are clear and free of obstructions.
2. The combustion air and intake pipes are in place, slopes back to the boiler and are physically sound without holes, sags or evidence of leaks.
3. The circulating water piping is physically sound, without missing pipe hangars or evidence of water leaks.
4. The physical support of the boiler is sound without sagging cracks, gaps, etc. around the base.
5. There are no obvious signs of deterioration of the boiler.

STARTING YOUR BOILER

This appliance does not have a pilot. It is equipped with an ignition device that automatically lights the burner. DO NOT try to light the burner by hand.

BEFORE OPERATING smell all around the appliance area for gas. Be sure to smell next to the floor because some gas is heavier than air and will settle on the floor.

WHAT TO DO IF YOU SMELL GAS

Do not try to light any appliance. Do not touch any electric switch; do not use any phone in your building. Immediately call your gas supplier from a neighbor's phone. Follow the gas supplier's instructions. If you cannot reach your gas supplier, call the fire department.

Use only your hand to turn the gas control knob. Never use tools. If the knob will not turn by hand, don't try to repair it; call a qualified service technician. Force or attempted repair may result in a fire or explosion.

Do not use this appliance if any part has been under water. Immediately call a qualified service technician to inspect the appliance and to replace any part of the control system and any gas control, which has been under water.

1. Set the thermostat to lowest setting. (See Fig. 11)
2. Turn off all electric power to the appliance. (See Fig. 12)

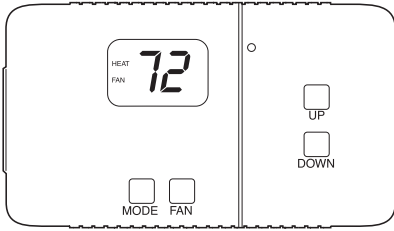

11

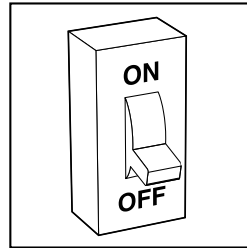

12

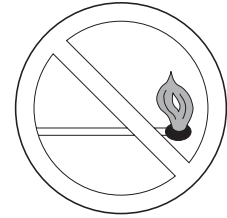

13

3. This appliance is equipped with an ignition device, which automatically lights the burner. DO NOT try to light the burner by hand.
4. Remove the front jacket panel. (See Fig. 14 or 16)
5. Turn the gas control knob clockwise to "OFF" on BW9 050, 075 and 100 models. (See Fig. 17) On BW9 125, 150, 175 and 200 models turn manual gas control valve to "OFF". (See Fig. 15)

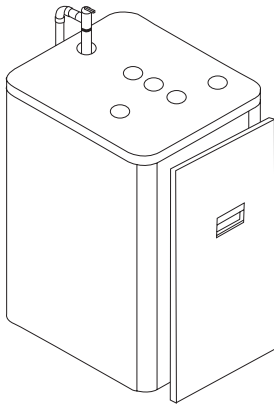

14

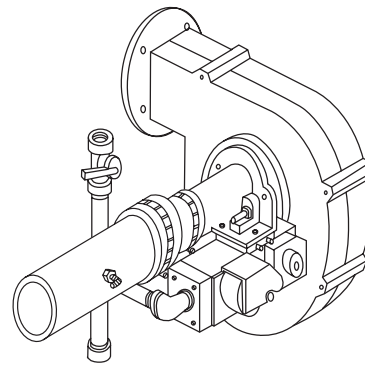

15

Model BW9-125 Through 200

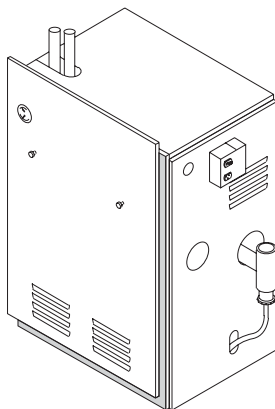

16

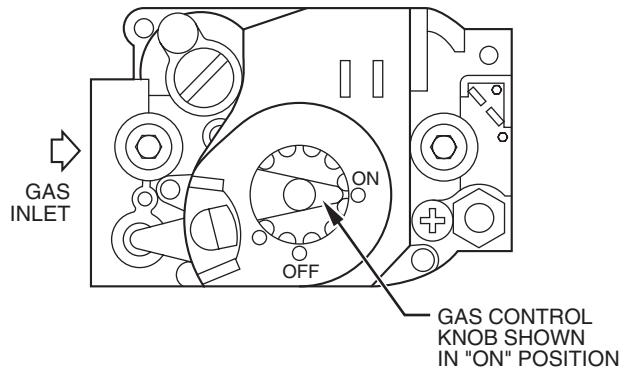

17

Model BW9-50 Through 100

6. Wait five (5) minutes to clear out any gas. Then smell for gas, including near the floor. If you smell gas, STOP! Follow "WHAT TO DO IF YOU SMELL GAS" in the instructions above. If you don't smell gas, go to next step.
7. Turn the gas control knob counterclockwise to "ON" for BW9 050, 075 and 100 models. (See Fig. 18) On BW9 125, 150, 175 and 200 models turn manual gas control valve to "ON". (See Fig. 19)

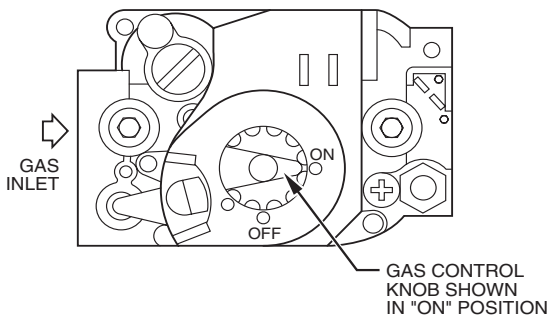

18

BW9-50 Through 100

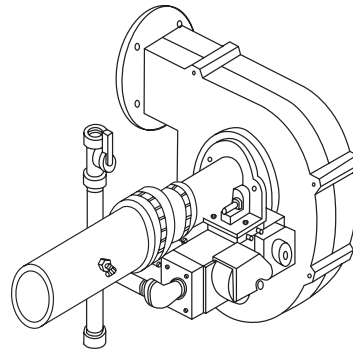

19

BW9-125 Through 200

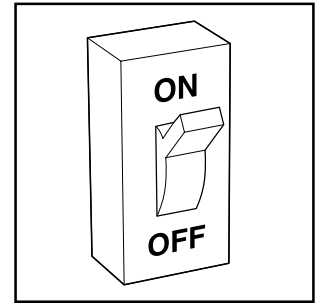

20

8. Replace the front jacket panel.
9. Turn on all electric power to the appliance. (See Fig. 20)
10. Set thermostat to desired setting.
11. If the appliance will not operate, follow the instructions “TO TURN OFF GAS TO APPLIANCE” and call your service technician or gas supplier.

SHUTTING DOWN YOUR BOILER

Once the heating season has ended, or should you ever suspect a malfunction in your boiler, you will want to turn the boiler off. The following procedures must be followed:

1. Set the thermostat to lowest setting. (See Fig. 21)
2. Turn off all electric power to the appliance. (See Fig. 22)
3. Remove the front jacket panel.

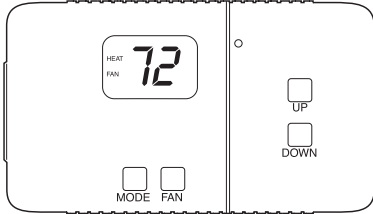

21

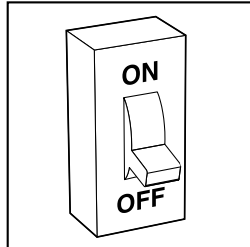

22

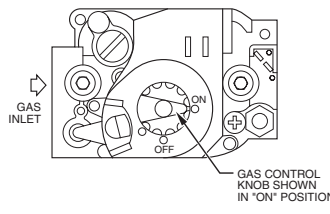

23

BW9-50 Through 100

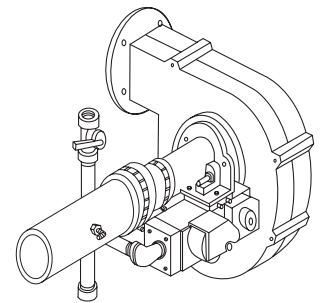

24

BW9-125 Through 200

4. Turn the gas control knob clockwise to “OFF”. Do not force. (See Fig. 23 or 24)
5. Replace the front jacket panel.

PERFORMING ROUTINE MAINTENANCE

With only routine maintenance and care, you can rely on your new boiler to operate economically for many years. Some of the maintenance you may want to do yourself. However, before performing any service on your boiler, please carefully consider the following:

1. Turn off electrical power supply to your boiler before removing access door to service or perform maintenance.

⚠ WARNING: ELECTRICAL SHOCK HAZARD. A failure to follow this warning could result in personal injury or death. Turn off electrical power supply to your boiler before removing the access doors to service or perform maintenance.

2. Although special care has been taken to reduce sharp edges to a minimum, be extremely careful when handling parts or reaching into boiler.

COMBUSTION AREA AND VENT SYSTEM

Visually inspect the combustion area and vent system before each heating season. When dirt, soot, scale, or rust builds up, your boiler can lose efficiency and perform improperly. Accumulations on the main burners can result in the burners firing out of normal sequence. This delayed ignition will create an alarmingly loud sound.

⚠ CAUTION: UNIT DAMAGE HAZARD. Failure to follow this caution may result in unit component damage. If your boiler makes an especially loud noise when the main burners light, shut down your boiler and call your dealer.

To inspect the combustion area and vent system, you will need a flashlight. Then referring to Fig. 25, 26, 27 or Fig. 28, 29 and 30 proceed as follows:

1. Turn the electrical supply to the boiler to OFF, and remove burner access door.

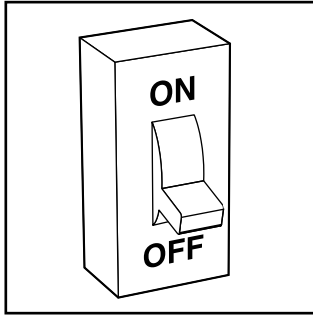

25

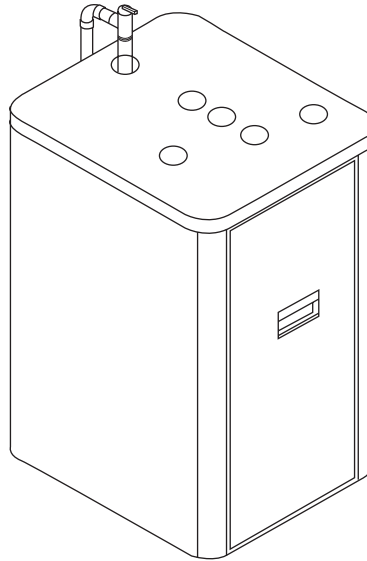

26

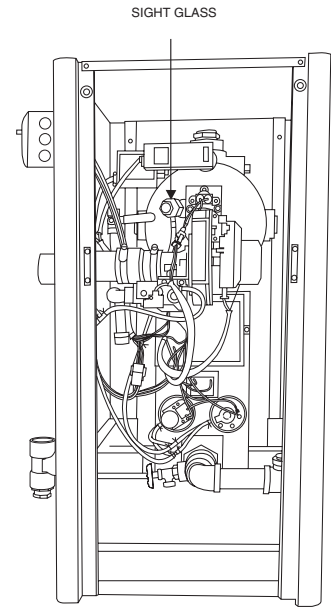

27

Model BW9-125 Through 200

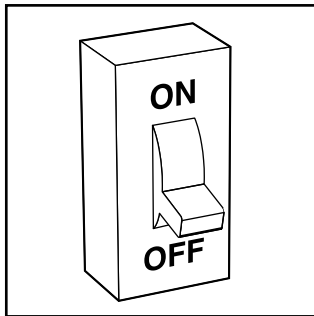

28

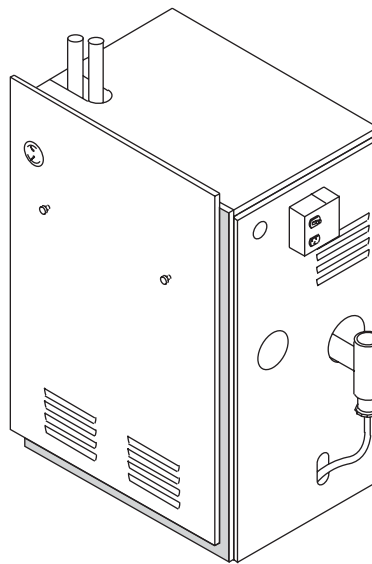

29

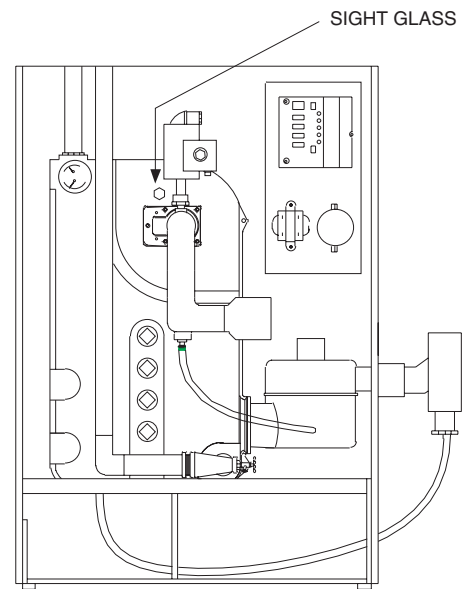

30

Model BW9-50 Through 100

2. Using the sight glass, carefully inspect the burner area including the burner for dirt, soot, or rust. Service and additional maintenance information can be located in the installation instructions.

⚠ CAUTION: UNIT OPERATION HAZARD. Failure to follow this caution may result in unit or property damage. If dirt, rust, soot, or scale accumulations are found, call your dealer. DO NOT OPERATE YOUR BOILER.

3. Inspect the exhaust pipe and combustion air pipe for sags, holes, or disconnections. Use Fig. 31 for reference.

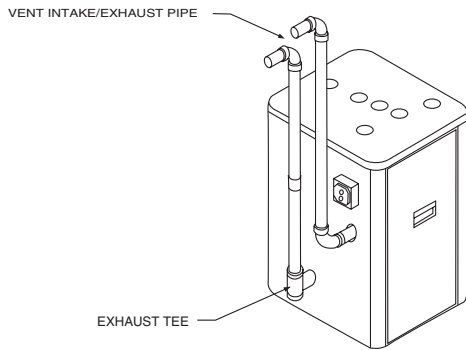

31

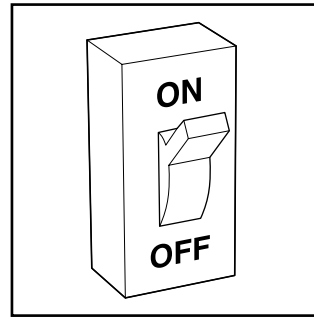

32

⚠ WARNING: CARBON MONOXIDE POISONING AND PROPERTY DAMAGE HAZARD. A failure to follow this warning could result in property damage, personal injury or death. If holes are found—or if the vent pipe is obstructed or is not connected—toxic fumes can escape into your home. DO NOT OPERATE YOUR FURNACE. Call your dealer for service.

4. Turn the electrical supply to the boiler to ON. (See Fig. 32)
5. Start your boiler and observe its operation. Watch the burner flames to see if they are bright blue. (See Fig. 27 or 30)
6. Replace front jacket panel.

If you observe a suspected malfunction, or that the burner flames are not bright blue, call your dealer.

A CHECKUP LIST

Your boiler represents an important investment in your family's comfort and your home's value. To keep it in tip-top shape and prevent future problems, have a trained service specialist give your boiler a professional checkup at least once each year. The following checklist can be used as a guideline to proper service.

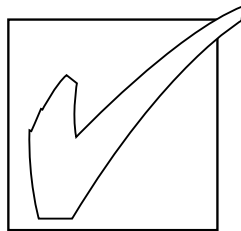

33

- Inspect all flue product passages including the burner, passages between the section, and exhaust and intake pipes.
- Remove and clean intake air baffle. Inspect all combustion and ventilation air passages and openings.
- Inspect electrical wiring, connections, and components for loose connections. Check gas pipes leading to and inside your boiler for leaks.
- Clean all drain lines.
- Perform an operational checkout to determine whether your boiler is working properly, and if it requires adjustments.
- Check all safety controls such as limit switch, pressure relief valve, etc. for proper operation.
- Consult the installation instructions for additional service and maintenance information.

If your boiler is not operating or not performing properly, you may save the expense of a service call by checking a few things yourself before calling for service.

BEFORE YOU REQUEST A SERVICE CALL IF YOUR BOILER FAILS TO OPERATE

Follow this checklist step by step, advancing to the next one only if boiler fails to operate.

- Check thermostat for proper temperature setting.
- Is electrical power supply to boiler on?
- Is manual shut-off valve in gas supply pipe in open position? (Follow start-up procedures if you open gas line.)

NOTE: Turn the electrical power to OFF and remove access doors before continuing with the checklist.

- Control dial on gas valve in ON position? (Follow start-up procedures if you must reset dial to ON.)

If your boiler still fails to operate, call your service representative.

For your convenience, record the model and serial numbers of your new boiler on the page provided in these instructions. Should you ever require service, you will have ready access to the information needed by the service representative.

© 2004 CAC/BDP, P.O. Box 70, Indianapolis, IN 46206