

**INSTALLER: LEAVE THIS MANUAL WITH THE APPLIANCE.  
CONSUMER: RETAIN THIS MANUAL FOR FUTURE REFERENCE.  
NEVER LEAVE CHILDREN OR OTHER AT RISK INDIVIDUALS ALONE WITH THE APPLIANCE.**

EN



# INSTALLATION AND OPERATING INSTRUCTIONS

CERTIFIED UNDER AMERICAN NATIONAL STANDARDS: ANSI Z21.11.2 FOR UNVENTED ROOM HEATERS.

**FOR INDOOR USE ONLY**

## SAFETY INFORMATION

### **WARNING**

If the information in these instructions are not followed exactly, a fire or explosion may result causing property damage, personal injury or loss of life.

- Do not store or use gasoline or other flammable vapors and liquids in the vicinity of this or any other appliance.

- **WHAT TO DO IF YOU SMELL GAS:**

- Do not try to light any appliance.
- Do not touch any electrical switch; do not use any phone in your building.
- Immediately call your gas supplier from a neighbour's phone. Follow the gas supplier's instructions.
- If you cannot reach your gas supplier, call the fire department.

- Installation and service must be performed by a qualified installer, service agency or the supplier.

- This is an unvented gas-fired heater that uses air (oxygen) from the room in which it is installed. Provisions for adequate combustion and ventilation air must be provided. Refer to section "COMBUSTION AND VENTILATION AIR PROVISIONS".

This appliance may be installed in an aftermarket, permanently located, manufactured (mobile) home, where not prohibited by local codes. This appliance is only for use with the type of gas indicated on the rating plate. This appliance is not convertible for use with other gases.

## WHVF24N

NATURAL GAS

## WHVF24P

PROPANE

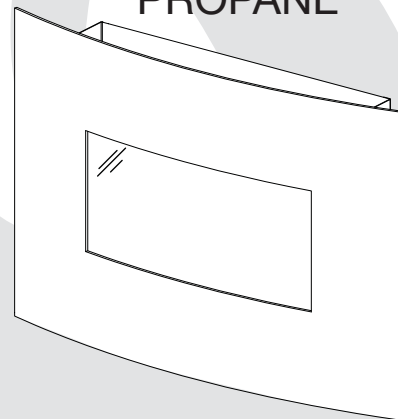

### **WARNING**

**HOT GLASS WILL CAUSE BURNS.**

**DO NOT TOUCH GLASS UNTIL COOLED.**

**NEVER ALLOW CHILDREN TO TOUCH GLASS.**



Quality System Certified To



APPLY SERIAL NUMBER LABEL FROM CARTON



Wolf Steel Ltd., 24 Napoleon Rd., Barrie, ON, L4M 0G8 Canada /  
103 Miller Drive, Crittenden, Kentucky, USA, 41030  
Phone (705)721-1212 • Fax (705)722-6031 • [www.napoleonfireplaces.com](http://www.napoleonfireplaces.com) • [hearth@napoleonproducts.com](mailto:hearth@napoleonproducts.com)

# TABLE OF CONTENTS

<b>1.0</b>	<b>INSTALLATION OVERVIEW</b>	<b>3</b>
<b>2.0</b>	<b>INTRODUCTION</b>	<b>4</b>
2.1	DIMENSIONS	5
2.2	GENERAL INSTRUCTIONS	5
2.3	GENERAL INFORMATION	6
2.4	RATING PLATE INFORMATION	7
<b>3.0</b>	<b>INSTALLATION</b>	<b>8</b>
3.1	COMBUSTION AND VENTILATION AIR PROVISIONS	8
3.2	DETERMINING CONFINED OR UNCONFINED SPACE	8
3.3	GAS INSTALLATION	10
3.4	MOBILE HOME	10
3.5	MOUNTING THE APPLIANCE	11
3.6	MINIMUM CLEARANCE TO COMBUSTIBLES	13
<b>4.0</b>	<b>FINISHING</b>	<b>14</b>
4.1	SURROUND INSTALLATION / REMOVAL	14
4.2	DOOR REMOVAL / INSTALLATION	15
4.3	GLASS MEDIA	16
<b>5.0</b>	<b>IGNITION SYSTEM DIAGRAM</b>	<b>16</b>
<b>6.0</b>	<b>OPERATION</b>	<b>17</b>
6.1	LIGHTING AND OPERATING INSTRUCTIONS	17
<b>7.0</b>	<b>ADJUSTMENTS</b>	<b>18</b>
7.1	VENTURI ADJUSTMENT	18
7.2	FLAME CHARACTERISTICS	18
<b>8.0</b>	<b>MAINTENANCE</b>	<b>19</b>
8.1	ANNUAL MAINTENANCE	20
8.2	CARE OF GLASS	21
8.3	CARE OF PLATED PARTS	21
8.4	DOOR GLASS REPLACEMENT	21
<b>9.0</b>	<b>REPLACEMENTS</b>	<b>22</b>
9.1	OVERVIEW	23
<b>10.0</b>	<b>TROUBLESHOOTING</b>	<b>24</b>
<b>11.0</b>	<b>WARRANTY</b>	<b>25</b>

**NOTE:** Changes, other than editorial, are denoted by a line in the margin.

## 1.0 INSTALLATION OVERVIEW

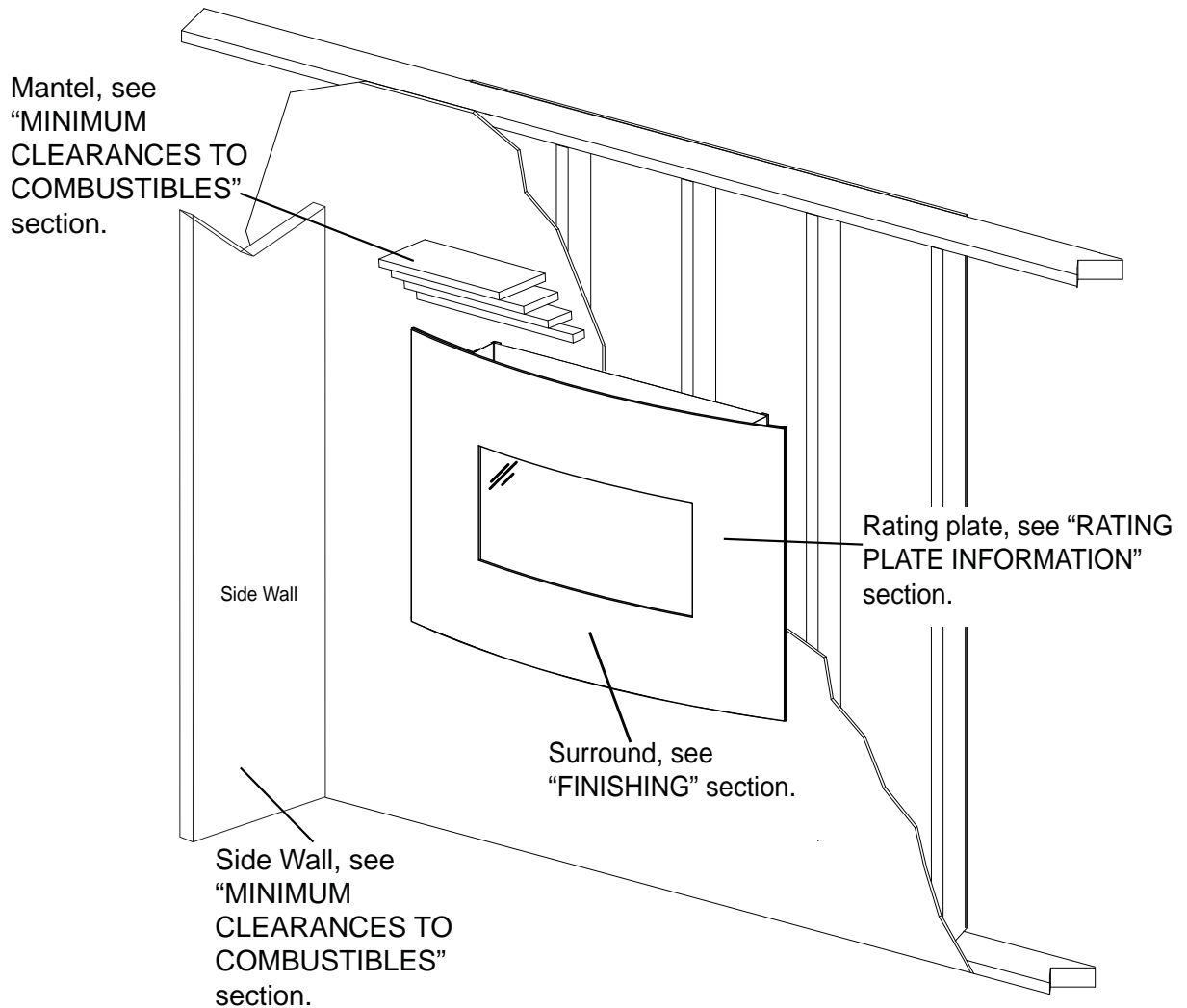

Batteries must be disposed of according to the local laws and regulations. Some batteries may be recycled, and may be accepted for disposal at your local recycling center. Check with your municipality for recycling instructions.

## 2.0 INTRODUCTION

### WARNING

- **THIS APPLIANCE IS HOT WHEN OPERATED AND CAN CAUSE SEVERE BURNS IF CONTACTED.**
- **ANY CHANGES TO THIS APPLIANCE OR ITS CONTROLS CAN BE DANGEROUS AND IS PROHIBITED.**
- Under no circumstances should this appliance be modified.
- Do not operate appliance before reading and understanding operating instructions. Failure to operate appliance according to operating instructions could cause fire or injury.
- Risk of burns. The appliance should be turned off and cooled before servicing.
- Do not install damaged, incomplete or substitute components.
- Risk of cuts and abrasions. Wear protective gloves and safety glasses during installation. Sheet metal edges may be sharp.
- Provide adequate ventilation and combustion air. Provide adequate accessibility clearance for servicing and operating the appliance. Never obstruct the front opening of the appliance.
- If the appliance shuts off, do not re-light until you provide fresh air. If appliance keeps shutting off, have it serviced. Keep burner and control compartment clean.
- Do not burn wood or other materials in this appliance.
- Children and adults should be alerted to the hazards of high surface temperature and should stay away to avoid burns or clothing ignition.
- Young children should be carefully supervised when they are in the same room as the appliance. Toddlers, young children and others may be susceptible to accidental contact burns. A physical barrier is recommended if there are at risk individuals in the house. To restrict access to an appliance, install an adjustable safety gate to keep toddlers, young children and other at risk individuals out of the room and away from hot surfaces.
- Due to high temperatures, the appliance should be located out of traffic and away from furniture and draperies.
- Ensure you have incorporated adequate safety measures to protect infants/toddlers from touching hot surfaces.
- Clothing or other flammable material should not be placed on or near the appliance.
- Check with your local hearth specialty dealer for safety screens and hearth guards to protect children from hot surfaces. These screens and guards must be fastened to the floor.
- Any safety screen or guard removed for servicing must be replaced prior to operating the appliance.
- It is imperative that the control compartments, burners and circulating blower and its passageway in the appliance are kept clean. The appliance should be inspected before use and at least annually by a qualified service person. More frequent cleaning may be required due to excessive lint from carpeting, bedding material, etc. The appliance area must be kept clear and free from combustible materials, gasoline and other flammable vapours and liquids.
- Furniture or other objects must be kept a minimum of 4 feet (1.2m) away from the front of the appliance.
- Do not use this appliance if any part has been under water. Immediately call a qualified service technician to inspect the appliance and to replace any part of the control system and any gas control which has been under water.
- Do not allow fans to blow directly into the appliance. Avoid any drafts that alter burner flame patterns.
- Do not use a blower insert, heat exchanger insert or other accessory not approved for use with this appliance.
- Carbon or soot should not occur in a vent free appliance as it can distribute into the living area of your home. If you notice any signs of carbon or soot, immediately turn off your appliance and arrange to have it serviced by a qualified technician before operating it again.
- Keep the packaging material out of reach of children and dispose of the material in a safe manner. As with all plastic bags, these are not toys and should be kept away from children and infants.
- As with any combustion appliance, we recommend having your appliance regularly inspected and serviced as well as having a Carbon Monoxide Detector installed in the same area to defend you and your family against Carbon Monoxide.
- If equipped, the screen must be in place (closed) when the appliance is in operation.
- Ensure clearances to combustibles are maintained when building a mantel or shelves above the appliance. Elevated temperatures on the wall or in the air above the appliance can cause melting, discolouration or damage to decorations, a T.V. or other electronic components.

3.4C

## 2.1 DIMENSIONS

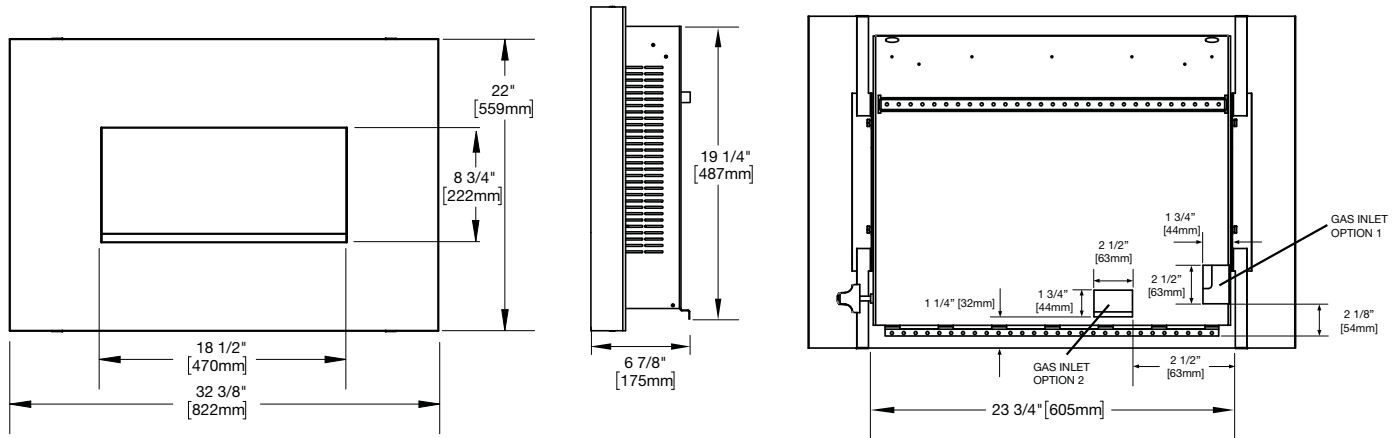

## 2.2 GENERAL INSTRUCTIONS

### **! WARNING**

**\* CARBON MONOXIDE POISONING MAY LEAD TO DEATH**

**EARLY SIGNS OF CARBON MONOXIDE POISONING RESEMBLE THE FLU, WITH HEADACHE, DIZZINESS AND/OR NAUSEA. IF YOU HAVE THESE SIGNS, THE HEATER MAY NOT BE WORKING PROPERLY. GET FRESH AIR AT ONCE! HAVE HEATER SERVICED.**

**SOME PEOPLE SUCH AS PREGNANT WOMEN, PERSONS WITH HEART OR LUNG DISEASE, ANEMIA, THOSE UNDER THE INFLUENCE OF ALCOHOL, THOSE AT HIGH ALTITUDES, ARE MORE AFFECTED BY CARBON MONOXIDE THAN OTHERS.**

**FAILURE TO KEEP THE PRIMARY AIR OPENING(S) OF THE BURNER(S) CLEAN MAY RESULT IN SOOTING AND PROPERTY DAMAGE.**

**THE APPLIANCE IS ONLY FOR USE WITH THE TYPE OF GAS INDICATED ON THE RATING PLATE. THIS APPLIANCE IS NOT CONVERTIBLE FOR USE WITH OTHER GASES. THIS APPLIANCE IS INTENDED FOR SUPPLEMENTAL HEATING.**

**OBJECTS PLACED IN FRONT OF THE HEATER SHOULD BE KEPT A MINIMUM OF 48" (1219.2mm) AWAY FROM THE FRONT FACE OF THE APPLIANCE. KEEP APPLIANCE AREA CLEAR AND FREE FROM COMBUSTIBLE MATERIALS, GASOLINE AND OTHER FLAMMABLE VAPORS AND LIQUIDS.**

**USE ONLY WOLF STEEL APPROVED OPTIONAL ACCESSORIES AND REPLACEMENT PARTS WITH THIS APPLIANCE. USING NON-LISTED ACCESSORIES AND REPLACEMENT PARTS (BLOWERS, LOUVRES, TRIMS, GAS COMPONENTS, VENT COMPONENTS, ETC.) COULD RESULT IN A SAFETY HAZARD AND WILL VOID THE LIMITED LIFETIME WARRANTY.**

**THIS APPLIANCE MUST NOT BE INSTALLED IN A BATHROOM.**

**DO NOT OPERATE WITHOUT CERAMIC CATALYST IN PLACE.**

This gas appliance should be installed and serviced by a qualified installer to conform with local codes. Installation practices vary from region to region and it is important to know the specifics that apply to your area, for example: in Massachusetts State:

- The appliance off valve must be a "T" handle gas cock.
- The flexible connector must not be longer than 36" (914.4mm).
- The appliance is not approved for installation in a bathroom unless the appliance is a direct vent sealed combustion product.
- A carbon monoxide detector is required in all rooms containing gas fired appliances.
- **WARNING:** This product must be installed by a licensed plumber or gas fitter when installed within the commonwealth of Massachusetts.
- Un-vented room appliance shall be installed in accordance with 527 CMR 30.00 and 248 CMR 3.00 through 7.00.
- Sellers of un-vented propane or natural gas-fired space / room appliances shall provide to each purchaser a copy of 527 CMR 30.00 upon the sale of the appliance from [http://www.napoleonfireplaces.com/Webshare/installation\\_manuals/mass\\_requirements.pdf](http://www.napoleonfireplaces.com/Webshare/installation_manuals/mass_requirements.pdf)

In absence of local codes, install the appliance to the current National Fuel Gas Code, ANSI Z223.1 Installation Code which can be obtained from:

**American National Standards Institute Inc.**  
1430 Broadway  
New York, NY 10018

or **National Fire Protection Association Inc.**  
Batterymarch Park  
Quincy, MA 02269

The appliance and its individual shutoff valve must be disconnected from the gas supply piping system during any pressure testing of that system at test pressures in excess of 1/2 psig (35mb). The appliance must be isolated from the gas supply piping system by closing its individual manual shutoff valve during any pressure testing of the gas supply piping system at test pressures equal to or less than 1/2 psig (35mb). When installed with a blower the junction box must be electrically connected and grounded in accordance with local codes. In the absence of local codes, use the current ANSI / NFPA 70 National Electric Code. In the case where the blower is equipped with a power cord it must be connected into a properly grounded receptacle. The grounding prong must not be removed from the cord plug.



We suggest that our gas hearth products be installed and serviced by professionals who are certified in the U.S. by the National Fireplace Institute® (NFI) as NFI Gas Specialists

As long as the required clearance to combustibles is maintained, the most desirable and beneficial location for the appliance is in the center of a building, thereby allowing the most efficient use of the heat created. The location of windows, doors and the traffic flow in the room where the appliance is to be located should be considered.

\* Air shortage caused by an inadequate air supply, improper log positions, the addition of foreign or unapproved materials or the failure to properly maintain the appliance, may result in incomplete combustion of the fuel. Incomplete combustion results in soot being deposited inside the firebox as well as surfaces outside the appliance. If any soot deposits are observed, shut off the appliance immediately and arrange for it to be serviced by a qualified technician. Incomplete combustion can also generate increased levels of carbon monoxide (CO).

## 2.3 GENERAL INFORMATION

**FOR YOUR SATISFACTION, THIS APPLIANCE HAS BEEN TEST-FIRED TO ASSURE ITS OPERATION AND QUALITY!**

RATES AND EFFICIENCIES		
	NATURAL GAS	PROPANE GAS
Altitude	0-2000*	0-2000*
Maximum Input	9,000 BTU/hr (2.6kw/hr)	9,000 BTU/hr (2.6kw/hr)
Efficiency	99.9%	99.9%
Minimum Inlet Gas Supply Pressure	4.5" Water Column (11.2mb)	11" Water Column (27.3mb)
Maximum Inlet Gas Supply Pressure	7" Water Column (17.4mb)	13" Water Column (32.8mb)
Manifold Pressure Under Flow Conditions	3.5" Water Column (8.7mb)	10" Water Column (25mb)

\* When the appliance is installed at elevations above 2,000ft (609.6m), and in the absence of specific recommendations from the local authority having jurisdiction, the certified high altitude input rating shall be reduced at the rate of 4% for each additional 1,000ft (304.8m).

This appliance is suitable for mobile home installation. The natural gas model can only be installed in a mobile home that is permanently positioned on its site and fueled with natural gas. This appliance may be installed in an aftermarket permanently located, manufactured (mobile) home, where not prohibited by local codes.

This appliance is only for use with the type of gas indicated on the rating plate. This appliance is not convertible for use with other gases.

The appliance is equipped with two catalytic tiles which are designed to filter out harmful gases and limit carbon monoxide output. It is likely that with the appliance in operation, the catalytic tiles will actually scrub the carbone monoxide normally found in the room and reduce it to a lower level. The tiles must not be altered or removed. Do not operate the appliances when using products such as paint, paint thinner, adhesives, etc. These products will permanently affect the catalytic tiles' ability to scrub the air.

Expansion / contraction noises during heating up and cooling down cycles are normal and are to be expected.

## 2.4 RATING PLATE INFORMATION

For rating plate location, see “INSTALLATION OVERVIEW” section.

This illustration is for reference only. Refer to the rating plate on the appliance for accurate information.

**NOTE:** The rating plate must remain with the appliance at all times. It must not be removed.

<p>CERTIFIED UNDER: ANSI Z21.11.2-2011 UNVENTED ROOM HEATER THIS APPLIANCE SHALL NOT BE INSTALLED IN BATHROOM, AND IS INTENDED FOR SUPPLEMENTAL HEATING. THIS APPLIANCE MAY BE INSTALLED IN AN AFTERMARKET, PERMANENTLY LOCATED, MANUFACTURED (MOBILE) HOME, WHERE NOT PROHIBITED BY LOCAL CODES. THIS APPLIANCE IS ONLY FOR USE WITH THE TYPE OF GAS INDICATED ON THE RATING PLATE. THIS APPLIANCE IS NOT FIELD CONVERTIBLE FOR USE WITH OTHER GASES. THIS IS A GAS-FIRED UNVENTED ROOM HEATER THAT REQUIRES ADEQUATE COMBUSTION AND VENTILATION AIR.</p>		 <p>CERTIFIED FOR / CERTIFIEE POUR CANADA / USA REFERENCE # 161746</p>	
<p><input type="checkbox"/> WHVF24N    <input type="checkbox"/> CWHVF24N    <input type="checkbox"/> CWHVF24P    <input type="checkbox"/> WHVF24P</p>			
<p><b>NATURAL GAS MODEL</b> *0-2000FT 9,000 BTU/HR BQ902C01 BENAN 20310 (NG)</p>		<p><b>PROPANE MODEL</b> *0-2000FT 9,000BTU/HR BQ902C01 BENAN 20310 (LP)</p>	
		<p><b>ALTITUDE</b> <b>INPUT</b> <b>CONTROL</b> <b>PILOT</b></p>	
<p>*ABOVE 2,000FT, CONSULT LOCAL AUTHORITY HAVING JURISDICTION.</p>			
<p>MANIFOLD PRESSURE: 3.5" WATER COLUMN (NG) MIN. SUPPLY PRESSURE: 4.5" WATER COLUMN (NG) MAX. SUPPLY PRESSURE: 7" WATER COLUMN (NG)</p>		<p>MANIFOLD PRESSURE: 10" WATER COLUMN (LP) MIN. SUPPLY PRESSURE: 11" WATER COLUMN (LP) MAX. SUPPLY PRESSURE: 13" WATER COLUMN (LP)</p>	
<p><b>NOT FOR USE WITH SOLID FUEL</b></p>			
<p><b>WARNING:</b> DO NOT ADD ANY MATERIAL TO THE APPLIANCE, WHICH WILL COME IN CONTACT WITH THE FLAME. DO NOT USE ACCESSORIES NOT APPROVED FOR USE WITH THIS APPLIANCE. APPLY LOOSE MATERIAL PER INSTRUCTIONS MANUAL. DO NOT APPLY EXTRA MATERIAL OR MATERIAL NOT SUPPLIED WITH THE APPLIANCE. IMPROPER INSTALLATION, ADJUSTMENT, ALTERNATION, SERVICE OR MAINTENANCE CAN CAUSE PROPERTY DAMAGE, PERSONAL INJURY OR LOSS OF LIFE. REFER TO THE OWNER'S INFORMATION MANUAL PROVIDED WITH THIS APPLIANCE. INSTALLATION AND SERVICE MUST BE PERFORMED BY A QUALIFIED INSTALLER, SERVICE AGENCY OR THE GAS SUPPLIER.</p>			
<p><b>MINIMUM CLEARANCE TO COMBUSTIBLE MATERIAL (FROM APPLIANCE):</b> MANTEL 20" FLOOR 10" SIDES 7"</p>			
<p><b>WOLF STEEL LTD.</b> 24 NAPOLEON ROAD, BARRIE, ON, L4M 0G8 CANADA</p>			
<p>SERIAL NUMBER</p>		<p>W385-1902_B</p>	



## 3.0 INSTALLATION

### 3.1 COMBUSTION AND VENTILATION AIR PROVISIONS

This appliance shall not be installed in a confined space or unusually tight construction unless provisions are provided for adequate combustion and ventilation air.

The National Fuel Gas Code, ANSI Z223.1 / NFPA 54 defines a confined space as a space whose volume is less than 50 cubic feet per 1,000 Btu per hour (4.8 m<sup>3</sup> per kw) of the aggregate input rating of all appliances installed in that space and an unconfined space as a space whose volume is not less than 50 cubic feet per 1,000 Btu per hour (4.8 m<sup>3</sup> per kw) of the aggregate input rating of all appliances installed in that space. Rooms communicating directly with the space in which the appliances are installed, through openings not furnished with doors are considered a part of the unconfined space.

17.1A

The WHVF24 is rated at 9,000 BTUs per hour for natural gas and propane and therefore requires a minimum unconfined space of 450 cubic feet.

### 3.2 DETERMINING CONFINED OR UNCONFINED SPACE

To determine the volume of the room where the appliance is to be installed, multiply the width x the length x the ceiling height of that room measured in feet. If any adjoining rooms are connected by grilles or openings such as kitchen pass-throughs, etc., the volume of those rooms may be added to the total.

Multiply the room volume by 1000 and divide this amount by 50 to determine the maximum BTU/hr that the space can support with adequate combustion and ventilation air.

Add the Btu/hr of all fuel burning appliances located within the space such as gas furnace, gas water appliance, etc. Do not include direct vent gas appliances which draw their input and output air from and to the outdoors.

#### WARNING

**IF THE AREA IN WHICH THE APPLIANCE MAY BE OPERATED IS SMALLER THAN THAT DEFINED AS AN UNCONFINED SPACE OR IF THE BUILDING IS OF UNUSUALLY TIGHT CONSTRUCTION, PROVIDE ADEQUATE COMBUSTION AND VENTILATION AIR BY ONE OF THE METHODS DESCRIBED IN THE NATIONAL FUEL GAS CODE ANSI Z223.1/ NFPA 54 , AIR FOR COMBUSTION AND VENTILATION, OR THE APPLICABLE LOCAL CODE.**

**IF THE AREA IN WHICH THE APPLIANCE MAY BE OPERATED DOES NOT MEET THE REQUIRED VOLUME FOR INDOOR COMBUSTION AIR, COMBUSTION AND VENTILATION AIR SHALL BE PROVIDED BY ONE OF THE METHODS DESCRIBED IN THE ANSI Z223.1 / NFPA 54, THE INTERNATIONAL FUEL GAS CODE, OR APPLICABLE LOCAL CODES.**

Unusually tight construction is defined as construction where:

- A) Walls and ceilings exposed to the outside atmosphere have a continuous water vapour retarder with a rating of 1 perm (6 x 10<sup>-11</sup> kg per pa-sec-m<sup>2</sup>) or less with openings gasketed or sealed, and
- B) Weather stripping has been added on openable windows and doors, and
- C) Caulking or sealants are applied to areas such as joints around window and door frames, between sole plates and floors, between wall-ceiling joints, between wall panels, at penetrations for plumbing, electrical, and gas lines, and at other openings.

An unvented room appliance is recommended for use as a secondary heat source rather than as a primary source. Gas combustion produces water vapour which could occur at the rate of approximately one ounce of water for every 1,000 BTU/hr of gas input. During the cold weather season, indoor humidity levels tend to be low. Consequently, this water vapour can enhance the living space. However if a problem should occur:

- A) Ensure sufficient combustion and circulation air
- B) Use a dehumidifier
- C) Do not use the unvented room appliance as a primary heat source

Without sufficient fresh air for proper operation, poor fuel combustion can result. Carbon Monoxide is a result of poor combustion.

If additional fresh air is required, use one of the methods described in the National Fuel Gas Code, ANSI Z223.1 / NFPA54 or the applicable local code.



Room Volume = Length x Width x Height  
 Max BTU/hr = Room Volume x 1000 / 50

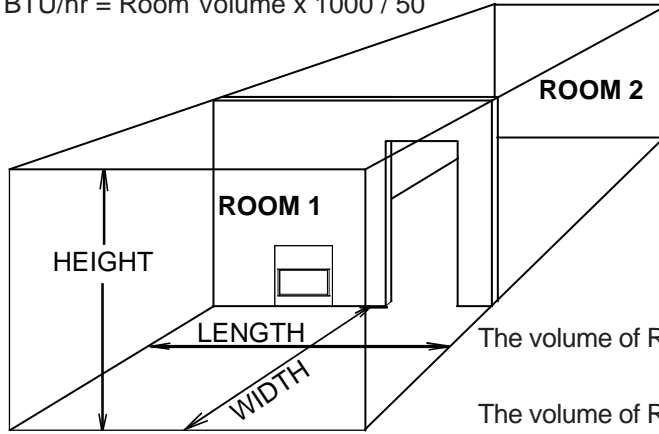

**If for example:**

The length of the rooms is 5 feet (1.5m),  
 The width of Room 1 is 10 feet (3.1m),  
 The width of Room 2 is 15 feet (4.6m),  
 The height of the rooms is 8 feet (2.4m).

The volume of Room 1:  $5 \times 10 \times 8 = 400$  cubic feet  
 ( $1.5 \times 3.1 \times 2.4 = 11.16$  cubic meters)

The volume of Room 2:  $5 \times 15 \times 8 = 600$  cubic feet  
 ( $1.5 \times 4.6 \times 2.4 = 16.56$  cubic meters)

19.1C

**EXAMPLE 1:**

In this example, because there is no door to the adjoining room, the volume of the adjoining room may be added to the volume of the room with the heater to get a total unconfined space.

The total unconfined space:  $400 \text{ ft}^3 (11.3\text{m}^3) + 600 \text{ ft}^3 (17\text{m}^3) = 1000$  cubic feet ( $28.3\text{m}^3$ ).

Maximum BTU/h:  $\frac{1000 \times 1000}{50} = 20,000$  BTU/h

19.2A

**EXAMPLE 2:**

If in this example a solid door separates Room 1 from Room 2, the volume of Room 2 could not be used. In this case the maximum BTU/h would be:

Maximum BTU/h:  $\frac{400 \times 1000}{50} = 8,000$  BTU/h

19.3

This would be considered a confined space since it can not support the 9,000 BTU/h input of the appliance and it would be necessary to provide adequate combustion and ventilation air to Room 1.

### 3.3 GAS INSTALLATION

 <b>WARNING</b>
<b>RISK OF FIRE, EXPLOSION OR ASPHYXIATION. ENSURE THERE ARE NO IGNITION SOURCES SUCH AS SPARKS OR OPEN FLAMES.</b>
<b>SUPPORT GAS CONTROL WHEN ATTACHING GAS SUPPLY PIPE TO PREVENT DAMAGING GAS LINE.</b>
<b>ALWAYS LIGHT THE PILOT WHETHER FOR THE FIRST TIME OR IF THE GAS SUPPLY HAS RUN OUT WITH THE GLASS DOOR OPENED OR REMOVED. PURGING OF THE GAS SUPPLY LINE SHOULD BE PERFORMED BY A QUALIFIED SERVICE TECHNICIAN. ASSURE THAT A CONTINUOUS GAS FLOW IS AT THE BURNER BEFORE CLOSING THE DOOR. ENSURE ADEQUATE VENTILATION. FOR GAS AND ELECTRICAL LOCATIONS, SEE “DIMENSIONS” SECTION.</b>
<b>ALL GAS CONNECTIONS MUST BE CONTAINED WITHIN THE APPLIANCE WHEN COMPLETE.</b>
<b>HIGH PRESSURE WILL DAMAGE VALVE. DISCONNECT GAS SUPPLY PIPING BEFORE TESTING GAS LINE AT TEST PRESSURES ABOVE 1/2 PSIG.</b>
<b>VALVE SETTINGS HAVE BEEN FACTORY SET, DO NOT CHANGE.</b>

Installation and servicing to be done by a qualified installer.

- Move the appliance into position and secure.
- If equipped with a flex connector the appliance is designed to accept a 1/2” (13mm) gas supply. Without the connector it is designed to accept a 3/8” (9.5mm) gas supply. The appliance is equipped with a manual shut off valve to turn off the gas supply to the appliance.
- Connect the gas supply in accordance to local codes. In the absence of local codes, install to the current CAN/CSA-B149.1 Installation Code in Canada or to the current National Fuel Gas Code, ANSI Z223.1 / NFPA 54 in the United States.
- When flexing any gas line, support the gas valve so that the lines are not bent or kinked.
- The gas line flex-connector should be installed to provide sufficient movement for shifting the burner assembly on its side to aid with servicing components.
- Check for gas leaks by brushing on a soap and water solution. **Do not use open flame.**

---

30.1A

### 3.4 MOBILE HOME

Suitable for mobile home installation where the mobile home has been permanently placed on its site. This appliance may be installed in an aftermarket permanently located, manufactured (mobile) home, where not prohibited by local codes.

For mobile home installations, the appliance must be fastened in place. It is recommended that the appliance be secured in all installations. See “REPLACEMENTS” section for the levelling / securing kit specific to your appliance.

---

29.2

### 3.5 MOUNTING THE APPLIANCE

- A. Level and affix the paper template to the wall at desired location and height. See “MINIMUM CLEARANCES TO COMBUSTIBLES” section for the minimum clearance requirement.
- B. Using the paper template, mark the mounting screw locations, see Figure 1.
- C. Install the mounting bracket onto the wall using the two screws as shown in Figure 2. Make sure the mounting bracket is level on the wall and the slots are facing upward. **NOTE: The mounting screws must go into a wall stud or proper anchors.**
- D. Mount the appliance onto the mounting bracket by placing the appliance into the slots until it is secured in place, see Figure 3. **NOTE: Ensure the appliance is resting securely in the slots.**
- E. Further secure the bottom of the appliance with the two screws, see Figure 4. **NOTE: It is strongly recommended that the appliance be screwed into the wall studs where possible. If the wall studs cannot be used, ensure that the proper anchors (not supplied) are used to affix the appliance to the wall and the appliance is adequately secured.**

FIG. 1

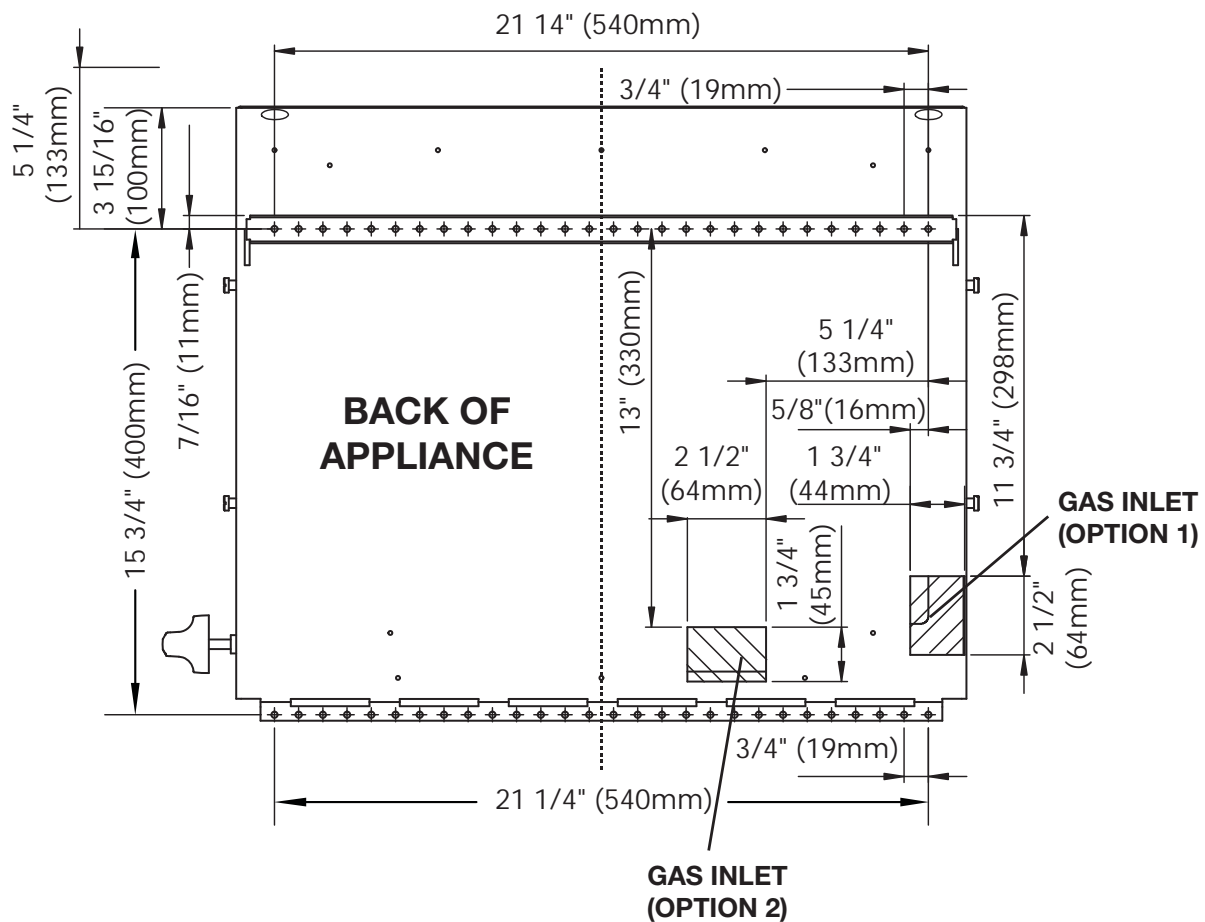

FIG. 2

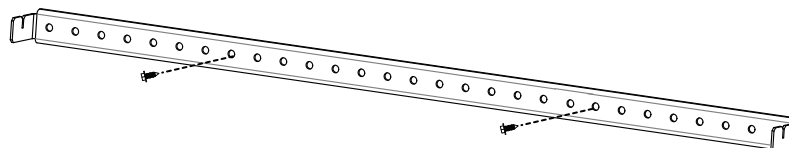

FIG. 3

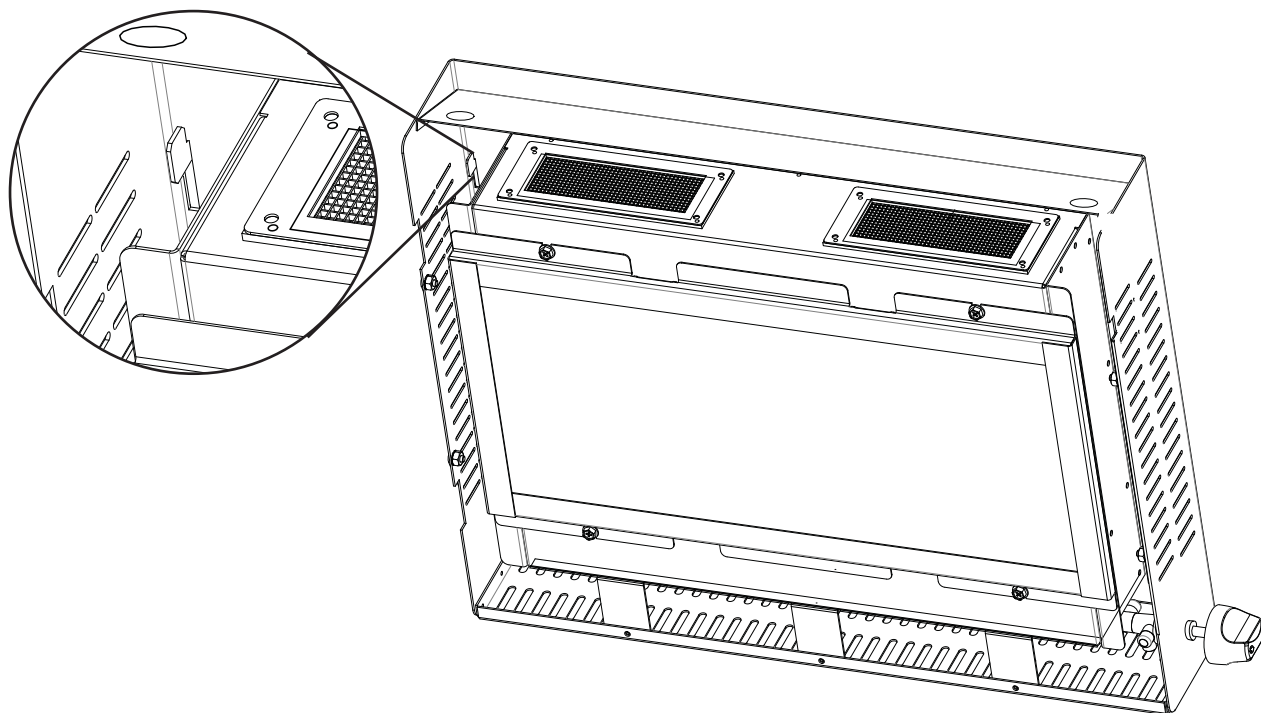
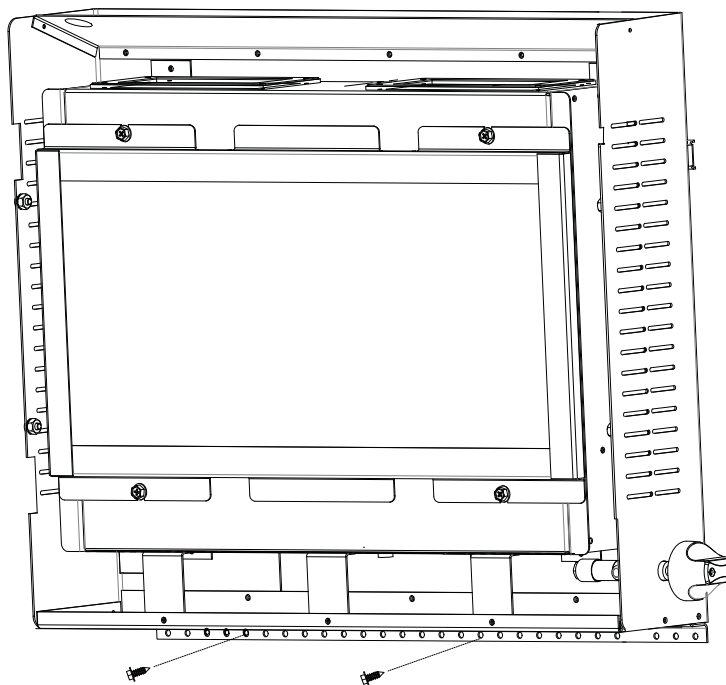

FIG. 4



### 3.6 MINIMUM CLEARANCE TO COMBUSTIBLES

Clearances are measured from the appliance.

#### MINIMUM CLEARANCES TO COMBUSTIBLES:

- 20" (508mm) to top
- 7" (178mm) to sides
- 10" (254mm) to bottom
- 36" (914mm) to rear

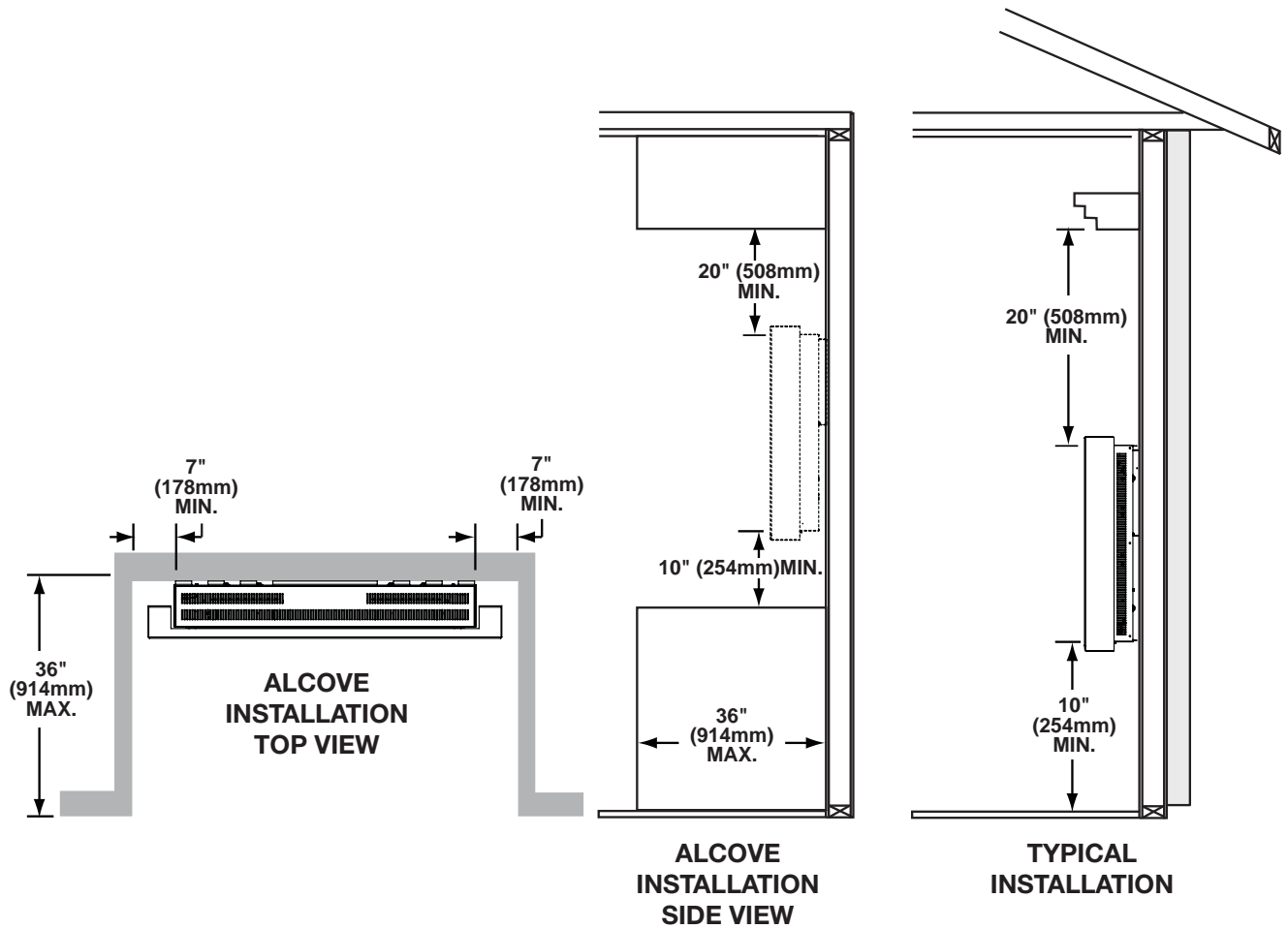

## 4.0 FINISHING

### **! WARNING**

**RISK OF FIRE!**

**NEVER OBSTRUCT THE FRONT OPENING OF THE APPLIANCE.**

**DO NOT STRIKE, SLAM OR SCRATCH GLASS. DO NOT OPERATE APPLIANCE WITH GLASS REMOVED, CRACKED, BROKEN OR SCRATCHED.**

72.4

### 4.1 SURROUND INSTALLATION / REMOVAL

- A. Lift the surround and engage the hooks into the studs on the appliance, then let it slide down into position.

**WARNING:**  
Do not let glass go until you ensure hooks have engaged the studs. Handle glass with care, if edge of glass strikes a hard surface, it will shatter.

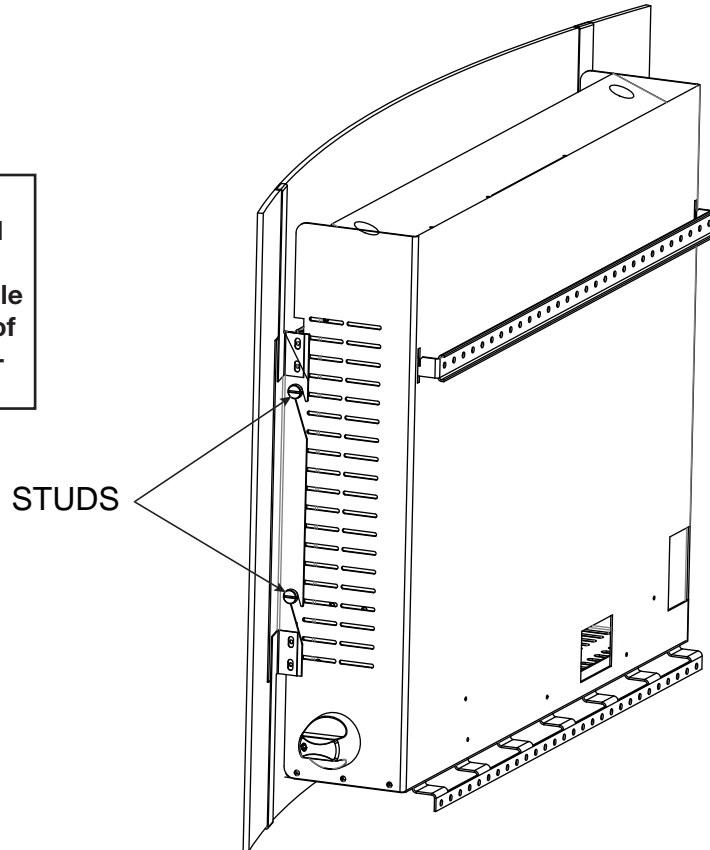

## 4.2 DOOR REMOVAL / INSTALLATION

### ! WARNING

GLASS MAY BE HOT, DO NOT TOUCH GLASS UNTIL COOLED.

IF EQUIPPED WITH DOOR LATCHES THAT ARE PART OF A SAFETY RELIEF SYSTEM, THEY MUST BE PROPERLY ENGAGED. DO NOT OPERATE THE APPLIANCE WITH LATCHES DISENGAGED.

FACING AND/OR FINISHING MATERIALS MUST NOT INTERFERE WITH AIR FLOW THROUGH AIR OPENINGS, LOUVRE OPENINGS, OPERATION OF LOUVRES OR DOORS OR ACCESS FOR SERVICE. OBSERVE ALL CLEARANCES WHEN APPLYING COMBUSTIBLE MATERIALS.

BEFORE DOOR IS REMOVED TURN THE APPLIANCE OFF AND WAIT UNTIL APPLIANCE IS COOL TO THE TOUCH. DOORS ARE HEAVY AND FRAGILE SO HANDLE WITH CARE.

75.1A

- A. Remove the surround, see “SURROUND INSTALLATION / REMOVAL” section.
- B. Remove the two screws on the upper frame that secure the door.  
Loosen the two screws on the lower frame. **NOTE: These lower screws support the door assembly and should not be removed.**
- C. Lift the door up and off.

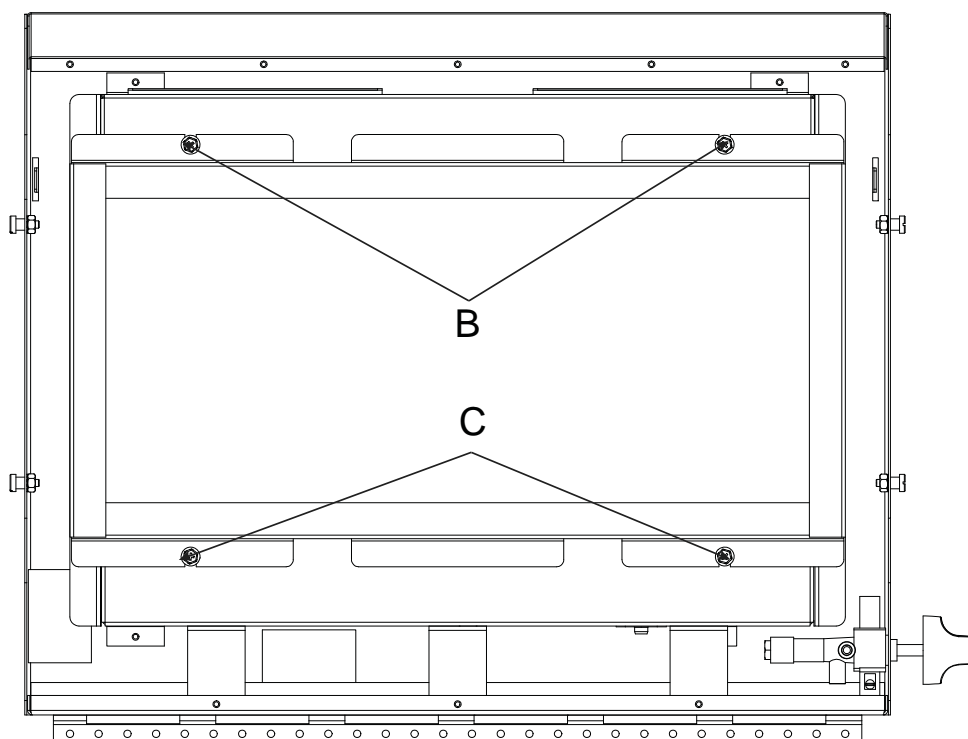



### 4.3 GLASS MEDIA

#### ! WARNING

CLEAN THE GLASS MEDIA PRIOR TO INSTALLATION. BEFORE APPLYING THE CLEANED GLASS, ENSURE THAT IT IS DRY.

DO NOT CHANGE OR SUBSTITUTE THE GLASS MEDIA MATERIAL PROVIDED WITH THIS APPLIANCE. IF REPLACING, USE ONLY THE REPLACEMENT GLASS MEDIA AVAILABLE FROM YOUR AUTHORIZED DEALER / DISTRIBUTOR.

GLASS MEDIA OVER THE BURNER MUST NOT BE MORE THAN ONE LAYER HIGH. MORE THAN ONE LAYER OVER THE BURNER WILL CAUSE FLAME LIFTING AND SOOTING PROBLEMS.

DO NOT PLACE ANY MEDIA (GLASS OR VERMICULITE) IN OR AROUND THE PILOT OPENING. THIS WILL INTERFERE WITH THE PILOT OPERATION.

Evenly spread the glass media onto the media tray, covering the burner tube and tray.

Glass media over the burner ports may cause a "Puffing" sound. To eliminate this sound, simply push the media away from the burner ports.

**NOTE:** The distribution of glass media over the burner ports will influence the flame height. When the flames impinge on the glass, the glass may discolour slightly and the edges may soften.

**NOTE:** Do not use more media than what was supplied with the appliance.

#### CLEANING GLASS MEDIA

Glass media may have a fine oil residue that needs to be cleaned prior to installation. Clean the glass with mild dish soap, drain, rinse thoroughly and dry before placing over the burner.

74.1C

## 5.0 IGNITION SYSTEM DIAGRAM

#### ! WARNING

TURN OFF THE APPLIANCE COMPLETELY AND LET COOL BEFORE SERVICING. ONLY A QUALIFIED SERVICE PERSON SHOULD SERVICE AND REPAIR THIS ELECTRIC APPLIANCE.

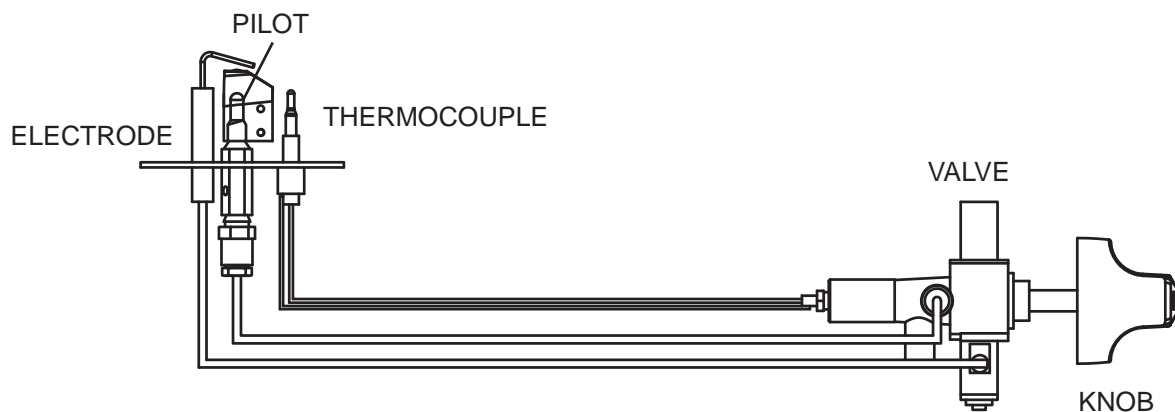

## 6.0 OPERATION

When lit for the first time, the appliance will emit a slight odour for a few hours. This is a normal temporary condition caused by the “burn-in” of internal paints and lubricants used in the manufacturing process and will not occur again. Simply open a window to sufficiently ventilate the room. After extended periods of non-operation such as following a vacation or a warm weather season, the appliance may emit a slight odour for a few hours. This is caused by dust particles in the heat exchanger burning off. Open a window to sufficiently ventilate the room.



### 6.1 LIGHTING AND OPERATING INSTRUCTIONS

- A. Locate the pilot adjustment knob on the bottom right of appliance.
- B. Push and turn the knob counter clockwise to the “PILOT ON” position and hold for a few seconds to ignite the pilot.
- C. Once the pilot is lit, slightly push the knob and turn counter clockwise to light the main burner.
- D. To adjust the flame height, push the knob and turn to desired height.

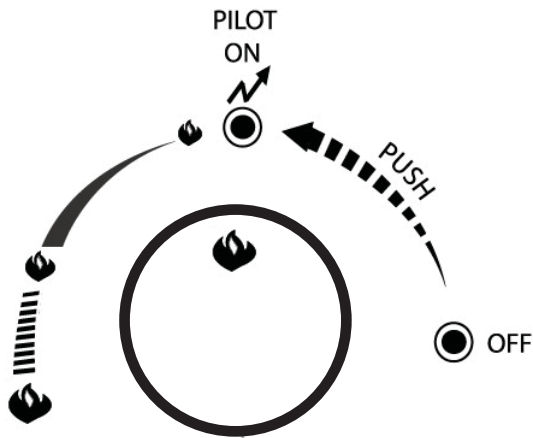
**NOTE:** When first lighting the pilot, push the knob and hold for 30 seconds to purge the gas line. **WARNING:** Do not hold for more than a minute.



#### FOR YOUR SAFETY READ BEFORE OPERATING LIGHTING INSTRUCTIONS

1. STOP! READ ALL INFORMATION OF OPERATING AND LIGHTING INSTRUCTIONS BEFORE PROCEEDING.
2. THIS FIREPLACE IS EQUIPPED WITH AN IGNITION DEVICE WHICH AUTOMATICALLY LIGHTS THE PILOT. DO NOT TRY TO LIGHT THE PILOT BY HAND.
3. TURN MANUAL SHUTOFF VALVE CLOCKWISE  TO OFF.
4. WAIT FIVE (5) MINUTES TO CLEAR OUT ANY GAS. IF YOU SMELL GAS INCLUDING NEAR THE FLOOR, STOP! FOLLOW “B” OF THE OPERATING INSTRUCTIONS. IF YOU DON’T SMELL GAS GO TO THE NEXT STEP.
5. TURN MANUAL SHUTOFF VALVE COUNTER-CLOCKWISE  TO ON.
6. TURN ON MAIN BURNER.

IF THE APPLIANCE WILL NOT OPERATE, FOLLOW THE INSTRUCTIONS “TO TURN OFF GAS” AND CALL YOUR SERVICE TECHNICIAN OR GAS SUPPLIER.

#### OPERATING INSTRUCTIONS



**WARNING:** IF YOU DO NOT FOLLOW THESE INSTRUCTIONS EXACTLY, A FIRE OR EXPLOSION MAY RESULT CAUSING PROPERTY DAMAGE, PERSONAL INJURY OR LOSS OF LIFE.

SEE INSTALLATION INSTRUCTIONS.

- A. THIS FIREPLACE IS EQUIPPED WITH AN IGNITION DEVICE WHICH AUTOMATICALLY LIGHTS THE PILOT. DO NOT TRY TO LIGHT BY HAND.
  - B. BEFORE OPERATING SMELL ALL AROUND THE FIREPLACE AREA FOR GAS AND NEXT TO THE FLOOR BECAUSE SOME GAS IS HEAVIER THAN AIR AND WILL SETTLE ON THE FLOOR.
- WHAT TO DO IF YOU SMELL GAS:
- TURN OFF ALL GAS TO THE FIREPLACE.
  - OPEN WINDOWS.
  - DO NOT TRY TO LIGHT ANY APPLIANCE.
  - DO NOT TOUCH ANY ELECTRIC SWITCH; DO NOT USE ANY PHONE IN YOUR BUILDING.
  - IMMEDIATELY CALL YOUR GAS SUPPLIER FROM A NEIGHBOUR’S PHONE. FOLLOW THE GAS SUPPLIER’S INSTRUCTIONS.
  - IF YOU CANNOT REACH YOUR GAS SUPPLIER, CALL THE FIRE DEPARTMENT.
- C. DO NOT TRY TO REPAIR ANY PART OF THIS ASSEMBLY. CALL A QUALIFIED SERVICE TECHNICIAN. FORCE OR ATTEMPTED REPAIR MAY RESULT IN A FIRE OR EXPLOSION.
  - D. DO NOT USE THIS FIREPLACE IF ANY PART HAS BEEN UNDER WATER. IMMEDIATELY CALL A QUALIFIED SERVICE TECHNICIAN TO INSPECT THE FIREPLACE AND REPLACE ANY PART OF THE CONTROL SYSTEM AND ANY GAS CONTROL WHICH HAS BEEN UNDER WATER.

#### TO TURN OFF GAS

2. TURN MANUAL SHUTOFF VALVE CLOCKWISE  TO OFF. DO NOT FORCE.

W385-1902\_B

## 7.0 ADJUSTMENTS

### 7.1 VENTURI ADJUSTMENT

This appliance has an air shutter that has been factory set open according to the chart below:

Regardless of venturi orientation, closing the air shutter will cause a more yellow flame, but can lead to carbonization. Opening the air shutter will cause a more blue flame, but can cause flame lifting from the burner ports. The flame may not appear yellow immediately; allow 15 to 30 minutes for the final flame colour to be established.

**AIR SHUTTER ADJUSTMENT MUST ONLY BE DONE BY A QUALIFIED INSTALLER!**

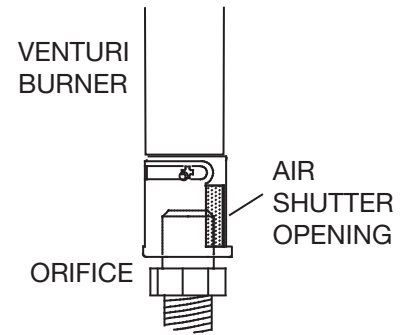

49.1

VENTURI ADJUSTMENT CHART	
FUEL	WHVF24
NG	0"
LP	1/16" (1.6mm)

### 7.2 FLAME CHARACTERISTICS

It is important to periodically perform a visual check of the pilot and burner flames. Compare them to the illustration provided. If any flames appear abnormal, call a service person.

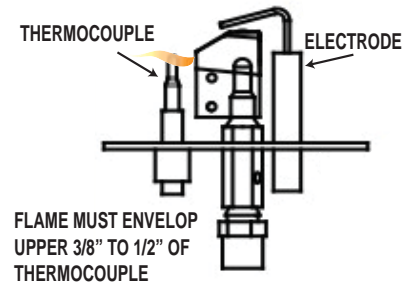
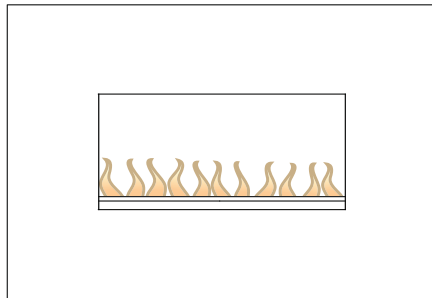

54.1B

## 8.0 MAINTENANCE

### **WARNING**

**TURN OFF THE GAS AND ELECTRICAL POWER BEFORE SERVICING THE APPLIANCE.**

**APPLIANCE MAY BE HOT, DO NOT SERVICE UNTIL APPLIANCE HAS COOLED.**

**DO NOT USE ABRASIVE CLEANERS.**

**DO NOT PAINT THE PILOT ASSEMBLY.**

**CAUTION:** Label all wires prior to disconnection when servicing controls. Wiring errors can cause improper and dangerous operation. Verify proper operation after servicing. This appliance and its venting system should be inspected before use and at least annually by a qualified service person. The appliance area must be kept clear and free of combustible materials, gasoline or other flammable vapors and liquids. The flow of combustion and ventilation air must not be obstructed.

1. In order to properly clean the burner and pilot assembly, remove the logs, rocks and/or glass to expose both assemblies.
2. Keep the control compartment, media, burner, air shutter opening and the area surrounding the logs clean by vacuuming or brushing, at least once a year.
3. Check to see that all burner ports are burning. Clean out any of the ports which may not be burning or are not burning properly.
4. Check to see that the pilot flame is large enough to engulf the flame sensor and/or thermocouple / thermopile as well as reaches the burner.
5. Replace the cleaned logs, rocks or glass. Failure to properly position the media may cause carboning which can be distributed in the surrounding living area.
6. Check to see that the main burner ignites completely on all openings when turned on. A 5 to 10 second total light-up period is satisfactory. If ignition takes longer, consult your local authorized dealer / distributor.
7. Check that the gasketing on the sides, top and bottom of the door is not broken or missing. Replace if necessary.
8. Blow or vacuum any dust or debris from the catalyst cells, ensuring they are all free from obstruction.

## 8.1 ANNUAL MAINTENANCE

### WARNING

**THE FIREBOX BECOMES VERY HOT DURING OPERATION. LET THE APPLIANCE COOL COMPLETELY OR WEAR HEAT RESISTANT GLOVES BEFORE CONDUCTING SERVICE.**

**NEVER VACUUM HOT EMBERS.**

**DO NOT PAINT THE PILOT ASSEMBLY.**

- This appliance will require maintenance which should be planned on an annual basis.
- Service should include cleaning, battery replacement, venting inspection and inspection of the burner, media and firebox. Refer to the door removal section and remove the door as instructed.
- Carefully remove media if necessary (logs, glass, brick panels etc).
- Using a vacuum with a soft brush attachment, gently remove any dirt, debris or carbon build up from the logs, firebox and burner. For glass media, follow the installation instructions for pre-cleaning.
- Also gently remove any build-up on the pilot assembly including, if equipped; thermopile, thermocouple, flame sensor and igniter. **NOTE: Clean flame sensor using a fine emery cloth or a synthetic scrub pad (such as Scotch-Brite™) to remove any oxides. Clean the pilot assembly using a vacuum with a soft brush attachment. It is important that the pilot assembly is not painted.**
- Inspect all accessible gaskets and replace as required.
- Access the blower, if equipped and clean using a soft brush and vacuum.
- Re-assemble the various components in reverse order.
- Inspect the relief system. The appliance relieves through the main glass door or through the flaps on the firebox top. Ensure they open freely, and close sealed.
- Check the gas control valve pilot and Hi / Lo knobs move freely (if equipped) – replace if any stiffness in movement is experienced.
- Check for gas leaks on all gas connections up and downstream from the gas valve including the pilot tube connections.

37.1E

## 8.2 CARE OF GLASS

**DO NOT CLEAN GLASS WHEN HOT! DO NOT USE ABRASIVE CLEANERS TO CLEAN GLASS.**

Buff lightly with a clean dry soft cloth. Clean both sides of the glass after the first 10 hours of operation with a recommended fireplace glass cleaner. Do not use an ammonia-based fireplace glass cleaner. Thereafter clean as required. If the glass is not kept clean permanent discoloration and / or blemishes may result.



5.1A

## 8.3 CARE OF PLATED PARTS

If the appliance is equipped with plated parts, you must clean fingerprints or other marks from the plated surfaces before operating the appliance for the first time. Use a glass cleaner or vinegar and towel to clean. If not cleaned properly before operating for the first time, the marks can cause permanent blemishes on the plating. After the plating is cured, the fingerprints and oils will not affect the finish and little maintenance is required, just wipe clean as needed. Prolonged high temperature burning with the door ajar may cause discoloration on plated parts.

**NOTE:** The protective wrap on plated parts is best removed when the assembly is at room temperature but this can be improved if the assembly is warmed, using a hair dryer or similar heat source.

6.1

## 8.4 DOOR GLASS REPLACEMENT

<b>! WARNING</b>
<b>DO NOT USE SUBSTITUTE MATERIALS.</b>
<b>GLASS MAY BE HOT, DO NOT TOUCH GLASS UNTIL COOLED.</b>
<b>CARE MUST BE TAKEN WHEN REMOVING AND DISPOSING OF ANY BROKEN DOOR GLASS OR DAMAGED COMPONENTS. BE SURE TO VACUUM UP ANY BROKEN GLASS FROM INSIDE THE APPLIANCE BEFORE OPERATION.</b>
<b>DO NOT STRIKE, SLAM OR SCRATCH GLASS. DO NOT OPERATE APPLIANCE WITH GLASS REMOVED, CRACKED, BROKEN OR SCRATCHED.</b>

Replacement glass/frame assembly shall be replaced as a complete unit as supplied by the appliance manufacturer.

56.1C

## 9.0 REPLACEMENTS

### **WARNING**

**FAILURE TO POSITION THE PARTS IN ACCORDANCE WITH THIS MANUAL OR FAILURE TO USE ONLY PARTS SPECIFICALLY APPROVED WITH THIS APPLIANCE MAY RESULT IN PROPERTY DAMAGE OR PERSONAL INJURY.**

Contact your dealer for questions concerning prices and policies on replacement parts. Normally, all parts can be ordered through your Authorized dealer / distributor.

**FOR WARRANTY REPLACEMENT PARTS, A PHOTOCOPY OF THE ORIGINAL INVOICE WILL BE REQUIRED TO HONOUR THE CLAIM.**

When ordering replacement parts always give the following information:

- Model & Serial Number of appliance
- Installation date of appliance
- Part number
- Description of part
- Finish

**PARTS, PART NUMBERS AND AVAILABILITY ARE SUBJECT TO CHANGE WITHOUT NOTICE.**

**PARTS IDENTIFIED AS STOCKED WILL BE DELIVERED WITHIN 2 TO 5 BUSINESS DAYS FOR MOST DELIVERY DESTINATIONS.**

**PARTS NOT IDENTIFIED AS STOCKED WILL BE DELIVERED WITHIN A 2 TO 4 WEEK PERIOD, FOR MOST CASES.**

**PARTS IDENTIFIED AS 'SO' ARE SPECIAL ORDER AND CAN TAKE UP TO 90 DAYS FOR DELIVERY.**

41.1C



## 9.1 OVERVIEW

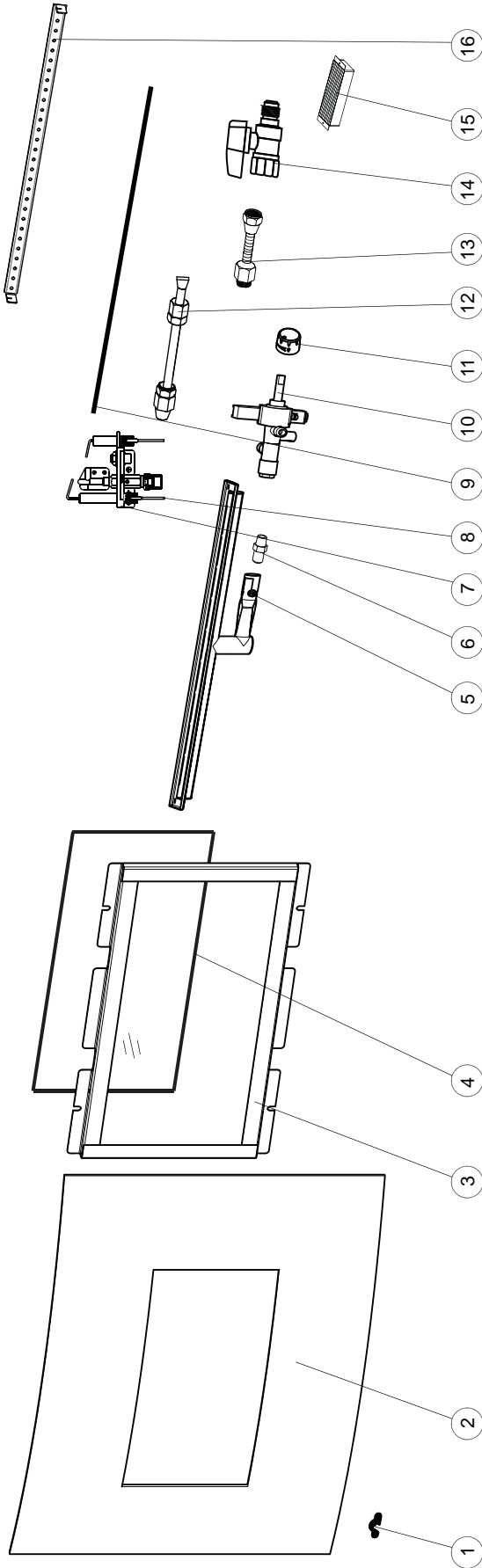

ITEMS MAY NOT APPEAR EXACTLY AS ILLUSTRATED

REF. NO.	PART NUMBER	DESCRIPTION	STOCKED
1	W385-2010	NAPOLEON LOGO	YES
2	G010-0035	CURVED FRONT GLASS ASSEMBLY	
3	G010-0032	COMPLETE DOOR ASSEMBLY	
4	W562-0071	DOOR GASKET	YES
5	G010-0028	BURNER ASSEMBLY	YES
6	W456-0055	BURNER ORIFICE #55 (NG)	YES
6	W456-0066	BURNER ORIFICE #66 (P)	YES
7	G240-0002N	ELECTRODE ODS (NG)	YES
7	G240-0002P	ELECTRODE ODS (P)	YES
8	G530-0003N	REGULATOR (NG)	YES

REF. NO.	PART NUMBER	DESCRIPTION	STOCKED
8	G530-0003P	REGULATOR (P)	YES
9	G750-0001	ELECTRODE WIRE (24")	
10	G530-0002	VALVE	
11	N380-0019B	KNOB	
12	G490-0001	BRASS TUBE	
13	N720-0044	FLEXIBLY CONNECTOR (12" X 3/8")	YES
14	W725-0046	GAS BALL VALVE	
15	G137-0001	CERAMIC CATALYST C/W CAN	
16	W080-1370	MOUNTING BRACKET	

## 10.0 TROUBLESHOOTING

### ! WARNING

**ALWAYS LIGHT THE PILOT WHETHER FOR THE FIRST TIME OR IF THE GAS SUPPLY HAS RUN OUT, WITH THE GLASS DOOR OPEN OR REMOVED.**

**TURN OFF THE GAS AND ELECTRICAL POWER BEFORE SERVICING THE APPLIANCE.**

**APPLIANCE MAY BE HOT, DO NOT SERVICE UNTIL APPLIANCE HAS COOLED.**

**DO NOT USE ABRASIVE CLEANERS.**

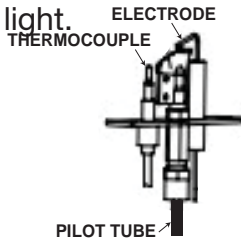
SYMPTOM	PROBLEM	TEST SOLUTION
Pilot will not light. 	Wiring.	- Verify the wire for the electrode and ignitor are connected.
	Loose connection.	- Verify no loose connections, electrical shorts in the wiring or ground out to any metal object.
	Igniter Spark gap is incorrect.	- Spark gap of the ignitor to the pilot should be 1/8" (3.2mm).
Pilot sparks but will not light.	Gas supply.	- Verify that the incoming gas line ball valve is "Open". Verify that the inlet pressure reading is within acceptable limits, inlet pressures must not exceed 14" W.C.(34.9mb)
	Out of propane gas.	- Fill the tank.
Carbon is being deposited on glass, logs, rocks, media or combustion chamber surfaces.	Air shutter has become blocked.	- Ensure air shutter opening is free of lint or other obstructions.
	Flame is impinging on the glass, logs, rocks, media or combustion chamber.	- Check that the glass, logs, rocks or media are correctly positioned. - Open air shutter to increase the primary air. - Check the input rate: check the manifold pressure and orifice size as specified in the instructions. - Check that the door gasketing is not broken or missing and that the seal is tight.
White / grey film forms.	Sulphur from fuel is being deposited on glass, logs or combustion chamber surfaces.	- Clean the glass, see "CARE OF GLASS" section <b>DO NOT CLEAN GLASS WHEN HOT.</b> - If deposits are not cleaned off regularly, the glass may become permanently marked.
Noisy Burner	Media Placement.	- In some installations, the glass media can lead to a "puffing" sound. Simply remove media covering burner ports.

## 11.0 WARRANTY

NAPOLEON products are manufactured under the strict Standard of the world recognized ISO 9001 : 2008 Quality Assurance Certificate.

NAPOLEON products are designed with superior components and materials assembled by trained craftsmen who take great pride in their work. The burner and valve assembly are leak and test-fired at a quality test station. The complete appliance is again thoroughly inspected by a qualified technician before packaging to ensure that you, the customer, receives the quality product that you expect from NAPOLEON.

### NAPOLEON GAS APPLIANCE PRESIDENT'S LIFETIME LIMITED WARRANTY

The following materials and workmanship in your new NAPOLEON gas appliance are warranted against defects for as long as you own the appliance. This covers: combustion chamber, heat exchanger, stainless steel burner, phazer™ logs and embers, rocks, ceramic glass (thermal breakage only), gold plated parts against tarnishing, porcelainized enameled components and aluminum extrusion trims.\*

Electrical (110V and millivolt) components and wearable parts are covered and NAPOLEON will provide replacement parts free of charge during the first year of the limited warranty. This covers: blowers, gas valves, thermal switch, switches, wiring, remote controls, ignitor, gasketing, and pilot assembly.\*

Labour related to warranty repair is covered free of charge during the first year. Repair work, however, requires the prior approval of an authorized company official. Labour costs to the account of NAPOLEON are based on a predetermined rate schedule and any repair work must be done through an authorized NAPOLEON dealer.

\* Construction of models vary. Warranty applies only to components included with your specific appliance.

### CONDITIONS AND LIMITATIONS

NAPOLEON warrants its products against manufacturing defects to the original purchaser only. Registering your warranty is not necessary. Simply provide your proof of purchase along with the model and serial number to make a warranty claim. NAPOLEON reserves the right to have its representative inspect any product or part thereof prior to honouring any warranty claim. Provided that the purchase was made through an authorized NAPOLEON dealer your appliance is subject to the following conditions and limitations:

Warranty coverage begins on the date of original installation.

This factory warranty is non-transferable and may not be extended whatsoever by any of our representatives.

The gas appliance must be installed by a licensed, authorized service technician or contractor. Installation must be done in accordance with the installation instructions included with the product and all local and national building and fire codes.

This limited warranty does not cover damages caused by misuse, lack of maintenance, accident, alterations, abuse or neglect and parts installed from other manufacturers will nullify this warranty.

This limited warranty further does not cover any scratches, dents, corrosion or discoloring caused by excessive heat, abrasive and chemical cleaners nor chipping on porcelain enamel parts, mechanical breakage of PHAZER™ logs and embers.

This warranty extends to the repair or replacement of warranted parts which are defective in material or workmanship provided that the product has been operated in accordance with the operation instructions and under normal conditions.

After the first year, with respect to this President's Lifetime Limited Warranty, NAPOLEON may, at its discretion, fully discharge all obligations with respect to this warranty by refunding to the original warranted purchaser the wholesale price of any warranted but defective part(s).

NAPOLEON will not be responsible for installation, labour or any other expenses related to the reinstallation of a warranted part and such expenses are not covered by this warranty.

Notwithstanding any provisions contained in the President's Lifetime Limited Warranty, NAPOLEON'S responsibility under this warranty is defined as above and it shall not in any event extend to any incidental, consequential or indirect damages.

This warranty defines the obligations and liability of NAPOLEON with respect to the NAPOLEON gas appliance and any other warranties expressed or implied with respect to this product, its components or accessories are excluded.

NAPOLEON neither assumes, nor authorizes any third party to assume, on its behalf, any other liabilities with respect to the sale of this product.

NAPOLEON will not be responsible for: over-firing, downdrafts, spillage caused by environmental conditions such as rooftops, buildings, nearby trees, hills, mountains, inadequate vents or ventilation, excessive venting configurations, insufficient makeup air, or negative air pressures which may or may not be caused by mechanical systems such as exhaust fans, furnaces, clothes dryers, etc.

Any damages to the appliance, combustion chamber, heat exchanger, plated trim or other components due to water, weather damage, long periods of dampness, condensation, damaging chemicals or cleaners will not be the responsibility of NAPOLEON.

All parts replaced under the President's Limited Lifetime Warranty Policy are subject to a single claim.

During the first 10 years NAPOLEON will replace or repair the defective parts covered by the lifetime warranty at our discretion free of charge. From 10 years to life, NAPOLEON will provide replacement parts at 50% of the current retail price.

All parts replaced under the warranty will be covered for a period of 90 days from the date of their installation.

The manufacturer may require that defective parts or products be returned or that digital pictures be provided to support the claim. Returned products are to be shipped prepaid to the manufacturer for investigation. If a product is found to be defective, the manufacturer will repair or replace such defect.

Before shipping your appliance or defective components, your dealer must obtain an authorization number. Any merchandise shipped without authorization will be refused and returned to sender.

Shipping costs are not covered under this warranty.

Additional service fees may apply if you are seeking warranty service from a dealer.

Warranty labour allowance is only for the replacement of the warranted part. Travel, diagnostic tests, shipping and other related charges are not covered by this warranty.

ALL SPECIFICATIONS AND DESIGNS ARE SUBJECT TO CHANGE WITHOUT PRIOR NOTICE DUE TO ON-GOING PRODUCT IMPROVEMENTS. NAPOLEON IS A REGISTERED TRADEMARK OF WOLF STEEL LTD.

Other Napoleon Products



Fireplace Inserts • Charcoal Grills • Gas Fireplaces • Waterfalls • Wood Stoves  
Heating & Cooling • Electric Fireplaces • Outdoor Fireplaces • Gas Grills



24 Napoleon Road, Barrie, Ontario, Canada L4M 0G8  
214 Bayview Drive, Barrie, Ontario, Canada L4N 4Y8  
103 Miller Drive, Crittenden, Kentucky, USA 41030  
7200 Trans Canada Highway, Montreal, Quebec, Canada H4T 1A3

Fireplaces / Heating & Cooling call: 705-721-1212 • Grills call: 705-726-4278

[napoleonproducts.com](http://napoleonproducts.com)