

SERIES 100 SINGLE PACKAGE ROOFTOP UNITS ENGINEERING GUIDE

50–65 Tons
Cooling and Heating (Gas, Electric, Water, and Steam)

R-410A

Mod F



LD19892



Nomenclature

BASE MODEL NUMBER YPAL 050-061

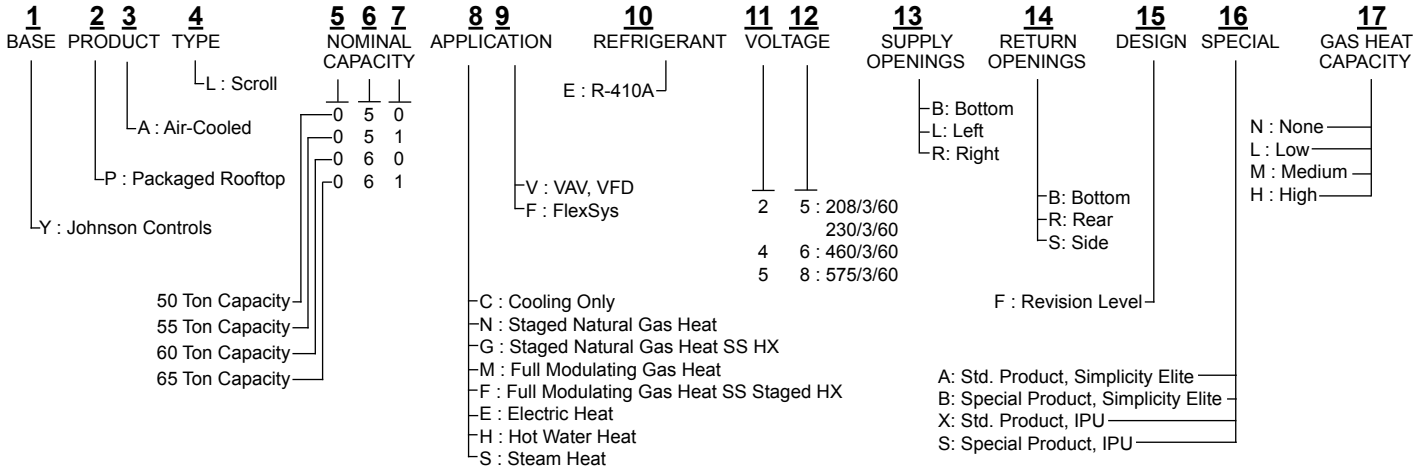

Table of Contents

INTRODUCTION	5
FEATURES AND BENEFITS	7
APPLICATION DATA	15
PHYSICAL DATA	21
ALTITUDE AND TEMPERATURE CORRECTIONS	25
COOLING PERFORMANCE DATA — 050 MODEL	27
COOLING PERFORMANCE DATA — 051 MODEL	28
COOLING PERFORMANCE DATA — 060 MODEL	29
COOLING PERFORMANCE DATA — 061 MODEL	30
HEATING PERFORMANCE DATA — GAS/ELECTRIC HEAT/HOT WATER COIL/ STEAM COIL	31
COMPONENT STATIC PRESSURE DROPS	32
SUPPLY FAN DATA	34
RETURN FAN DATA	36
ELECTRICAL DATA	37
CONTROLS	39
SPECIAL DESIGN OPTIONS	52
GENERAL ARRANGEMENT DRAWINGS	53
UNIT WEIGHTS	58
HOT WATER/STEAM COIL CONNECTION LOCATIONS	61
POWER/CONTROL ENTRY DRAWING — 50–61 MODELS	62
GUIDE SPECIFICATIONS	63

THIS PAGE INTENTIONALLY LEFT BLANK.

Introduction

The Johnson Controls Series 100 Single Package Units – designed to meet the demands of the market for today and tomorrow.

Better Economy...

Lower total cost of ownership

- **Accurate Ventilation Control:** Ensures that no more than the proper amount of ventilation air is utilized. This avoids the energy cost of conditioning excess outside air and simultaneously monitors all other unit functions for maximized energy efficiency.
- **Flexible Design:** Configurations simplify the design process and allow the Johnson Controls Series 100 to be applied to virtually any building application.
- **Easy Access:** Through double-wall access doors, spacious compartments and supportive floors to improve serviceability.
- **Scroll Compressor:** Provides high efficiency, quiet operation, and maximum reliability.
- **Modulating Gas Heat Option:** Precise temperature control in heating mode.

Better Ecology...

Indoor air quality features for the indoor environment

- **Double-Wall Construction:** The roof, floor, doors, and walls prevent insulation fibers from entering the conditioned air. The inner liner also facilitates periodic cleaning of the unit to prevent harmful build-up of bacteria or contaminants.
- **Filtration:** Up to MERV 14, the filters provide high air quality in buildings. Johnson Controls is providing different choices of filters in mixed air section, as well as a final filtration option.
- **CO₂ Sensor:** Available to control IAQ. The unit control center uses microprocessor logic to analyze and optimize ventilation decisions and perform demand ventilation, as well as allow airflow compensation to maintain the air quality at a healthy level.

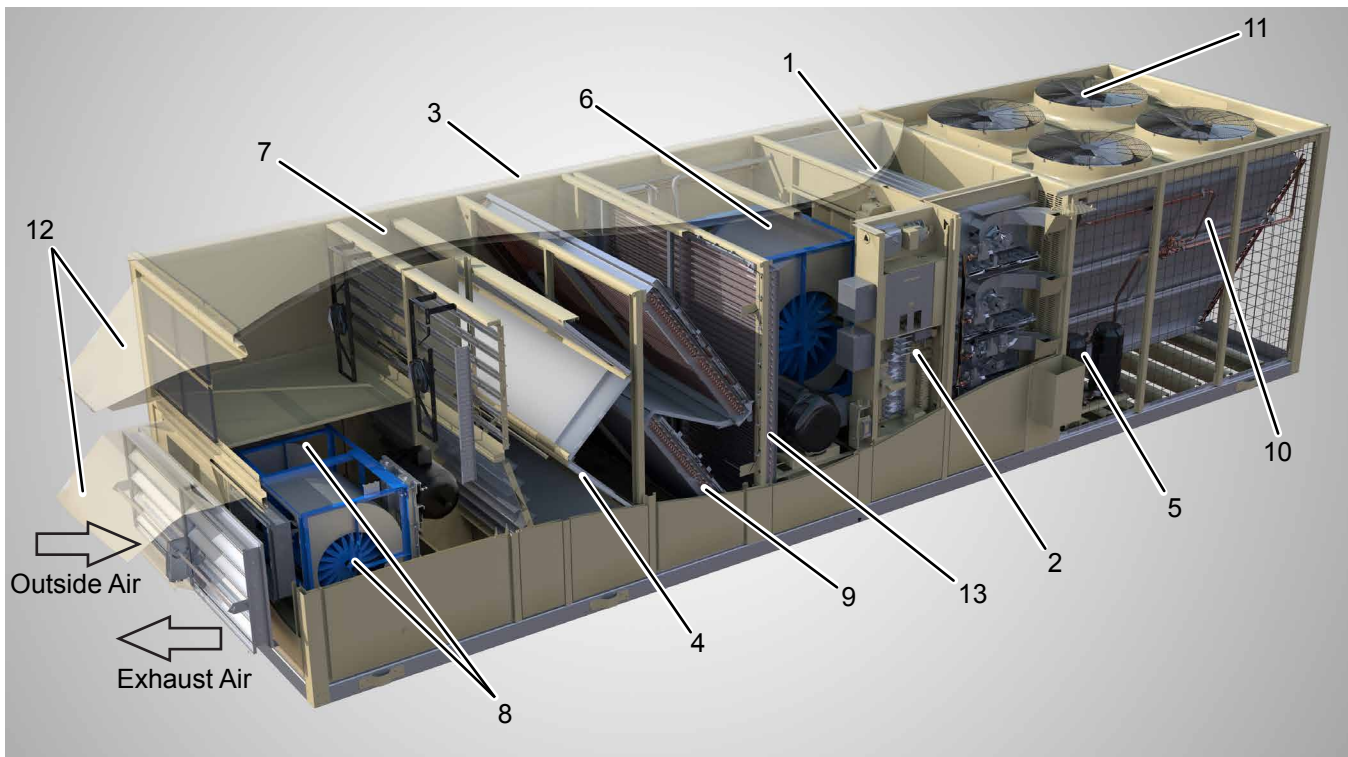

LD20074

FIGURE 1 - STANDARD CABINET ASSEMBLY

Features and Benefits

1. **Modulating or Staged Gas Heat**
 - Available in stainless steel as an option.
 - Suitable for natural or propane gas as an option.
 - Modulating gas heat is available for improved temperature control.
 - Staged gas has three modules (375 mbh with two staged each) available for YPAL units with bottom discharge, and two are available with left-side discharge.
2. **Advance Single Package Unit Controller**
 - Microprocessor-based single package IPU controller.
 - Factory-installed, programmed and commissioned with I/O capabilities and control sequences.
 - Easy access for diagnostics.
 - BACnet or LonWorks communications capabilities.
3. **Double-Wall Construction**
 - Standard construction of the Johnson Controls Series 100.
 - Powder coated, pre-fabricated panels.
 - Corner post for maximum exterior surface protection
4. **Filters Section** - Series 100 has multiple filtration options to improve IAQ
 - 2" cleanable
 - 2" pleated MERV 8
 - 2" carbon MERV 8
 - 2" MERV 8 (pre-filter) + 12" MERV 11
 - 2" MERV 8 (pre-filter) + 12" MERV 14
5. **Scroll Compressors**
 - Reliable, efficient, trouble-free operation.
 - Simplicity of a hermetic scroll compressor allows the use of fewer moving parts to minimize breakdowns.
 - Two compressors per circuit and two circuits per unit proved redundancy and help maintain comfort inside your building.
6. **Double Width, Double Inlet (DWDI), Forward-Curved Supply Fan or Airfoil Supply Fan**
 - Airfoil supply fan - option offers higher efficiency and lower sound in certain applications.
 - Forward-curved fan - suitable for medium static pressures and high air-flows.
7. **Economizer**
 - Modulating outdoor air and return air dampers helps improve IAQ in your building.
 - Available with low-leak dampers as an option.
 - YPAL can be equipped with one of three types of economizer control: dry bulb, single enthalpy, or dual enthalpy.
8. **Exhaust or Return Fan**
 - Exhaust fan - available with constant-speed exhaust fan or with VFD to modulate the speed.
 - Return fan - includes SWSI plenum fan(s) to control building pressure. The fan motors are driven by VFD to maintain a constant return plenum pressure.
9. **Evaporator Coil**
 - Copper fins (optional) are available for extreme climate conditions.
10. **Condenser**
 - Copper fins (optional) are available for extreme climate conditions.
11. **Condenser Fans**
12. **Rain Hoods**
13. **Modulating Hot Gas Reheat**
 - Provides comfort benefits and energy efficient operation to building applications where space dehumidification is a customer concern.

Features and Benefits (Cont'd)

AIRFLOW CONFIGURATIONS

Variable-Air-Volume – Series 100 units are available for a traditional overhead Variable Air Volume system. In this configuration, the Supply Fan speed is controlled by a VFD to maintain duct pressure. The duct pressure setpoint can be fixed or it can be reset via a BAS or a 0-5VDC analog input for optimized duct static pressure control. Operating mode (cooling, heating, ventilation) changes are controlled by the Return Air Temperature. However, a space temperature sensor or BAS must be used for Night Set Back and Morning Warm Up operation.

Note: For duct pressure control, a Duct Static Pressure Transducer is included. However, 5/16- or 1/4-inch plastic tubing and a static pressure probe must be field supplied/installed approximately 3/4 down the longest supply duct run.

Single Zone VAV – Series 100 is available for single zone variable air volume (VAV) applications in compliance with ASHRAE 90.1-2010 and 2013. In cooling mode, refrigeration capacity or compressor stages are cycled on or off to maintain supply air temperature. Likewise in heating, additional stages are cycled on or are modulated on to maintain supply air temperature setpoint. The supply fan speed is modulated to maintain zone temperature setpoint. The S100 uses either a BAS signal or a zone temperature sensor to determine zone temperature and deviation from setpoint. Either a BAS signal or a zone temperature sensor is required in the conditioned space.

FlexSys Underfloor Air VAV – Series 100 units are configurable for underfloor VAV applications. Control can be used with a zone sensor or building automation system. Supply fans are controlled to the supply duct static pressure setpoint, which can be reset via a BAS or through a 0-5VDC analog input on the unit controller for optimized duct static pressure control.

Flexsys bypass control option is not available with the Simplicity Elite Controller.

COOLING AND HEATING CONFIGURATIONS

Cooling Only – For applications where no heat is required, or heating is provided elsewhere within the building HVAC system, cooling only units include an empty discharge plenum. Supply duct connections are configurable for bottom, left or right discharge. The supply air temperature sensor is included and factory-installed.

Staged Gas Heat – For applications requiring gas heat for morning warm-up, or other heating needs, a staged natural gas furnace is available. The furnace is located in the discharge plenum, downstream of the supply fan. The supply air temperature sensor is located across the face of the supply duct opening in the unit. Furnaces are designed in 375 mbh modules with two stages each. Three 375 mbh modules are available on the YPAL050-061 with bottom discharge and two are available on the YPAL050-061 with left-side discharge. Ignition and safety controls are included and factory-wired.

Modulating Gas Heat – For more precise control of temperature, a modulating gas heat option is available. Furnaces are designed in 375 mbh modules with three turndown ratios in 8:1 increments. On YPAL050-065, there are 8:1, 16:1, and 24:1 turndown ratios.

Gas furnace is suitable for natural gas applications and liquid propane applications. A conversion kit is required for liquid propane applications.

Both staged gas and modulating gas are available in the stainless steel version.

Modulating Hot Gas Reheat – The Series100 Modulating Hot Gas Reheat (HGRH) design provides comfort benefits and energy efficient operation to building applications where space dehumidification is a customer concern.

Variable occupancy building design combined with high OA or ventilation requirements place a unique demand on typical packaged rooftop unit operation. During partial or low load occupancy use or during high humidity OA loads, when space temperature is met, the refrigeration system will cycle off after short operating periods. These short operating cycles can lead to humidity control problems and overcooling of the space. The Series100 Modulating HGRH option redirects the hot refrigerant gas leaving the compressor to a separate coil downstream of the evaporator cooling coil, in effect providing reheat function (at no additional energy cost) for the air off the cooling coil. Educational facilities, places of worship, restaurants, gymnasiums, and museums/learning centers are all applications that benefit from the enhanced humidity control of Series100 Modulating HGRH rooftop option.

The Series100 unit IPU controller energizes the HGRH operation when dehumidification is needed, controlling the modulating valve, reheat coil, and cooling coil to maintain the consistent levels humidity and temperature control needed by the building space. This operation adds sensible heat to the supply air being delivered to the space and allows the evaporator cooling coil to operate at a lower temperature, removing excess moisture without overcooling the conditioned space.

Altitude – (1000 feet up to 6000 feet) If your product's destination is above sea level, please select current altitude. Due to air density, corrections are needed to outline the correct unit performance. The altitude will affect cooling and gas heating performance. It will not affect other heating options, such as electrical, hot water, or steam coils. Most likely, in order to maintain desired static pressures at higher altitudes, higher RPM motors may be required. At the same time, lower heat may be required due to a decrease in air density. High altitude heating options will be required for altitude higher than 2000 feet above sea level. All calculations are for the U.S. territory.

Electric Resistance Heat – For applications where electric heat is desired, a slip-in electric resistance heat element is available in sizes from 40-150 kW depending on the rooftop model size. The number of stages varies by size and voltage, but all have a minimum of two stages of capacity. Units with electric heat are ETL listed.

Hot Water Heat – For applications where hot water is available for heating, a hot water heating coil is available. A range of coil fin count selections are available to properly size the heating for the application. Units with hot water heat are ETL listed. See *Hot Water/Steam Coil Connection Locations on page 61, Table 2 on page 21, and Table 11 on page 31* for more information.

Steam Heat – For applications where steam is available for heating, a steam heating coil is available. A range of coil fin count selections are available to properly size the heating for the application. Units with steam heat are ETL listed. See *Hot Water/Steam Coil Connection Locations on page 61, Table 2 on page 21, and Table 12 on page 31* for more information.

POWER OPTIONS

Single-point supply with terminal block – This configuration is standard, and includes three terminals for the incoming 3-phase power and is the standard configuration for the Johnson Controls Series 100 product. It includes the enclosure, terminal-block, and interconnecting wiring to the compressors, heater and furnace controls, all fans, etc. In this configuration, code requires that a means of disconnect (not provided) must be installed at the site within line-of-sight of the equipment.

Features and Benefits (Cont'd)

Single-point supply with non-fused disconnect switch – This option is the same as the single-point with terminal block option except it includes a unit-mounted through-the-door manual non-fused disconnect switch with an external, lockable handle (in compliance with Article 440-14 of N.E.C.). This option provides a means to isolate the unit power voltage for servicing. Others must supply separate external fusing which must comply with the National Electric Code and/or local codes.

Dual-point supply with terminal block – This option includes enclosure, terminal blocks circuited to the supply and exhaust fans and control transformer and a second set of terminal blocks with interconnecting wiring to the compressors, heat (if applicable) and condenser.

Convenience Outlet – This option includes a powered 115V GFCI convenience outlet that can be used for powering tools or lights for servicing. A protective cover plate is included while not in use. The outlet is located on the bottom left hand corner of the power panel.

CONTROL FEATURES AND OPTIONS

Standard Controller

Microprocessor-Based Single Package IPU Unit Controller – All Series 100 units are equipped with a factory-installed, programmed and commissioned unit controller with all I/O capabilities and control sequences. The controls include all on-board diagnostic, safety and control features to operate the single package unit. A multimedia card interface is included for software upgrades and can be used for data logging to simplify equipment troubleshooting. Communication ports are included as standard with three alarm outputs, a shutdown contact, remote start/stop input, smoke ventilation controls, analog inputs for supply air temperature and duct static pressure reset, along with a variety of other capabilities.

Optional Controller

Simplicity Elite Unit Controller – All Johnson Controls Series 100 units are equipped with a factory-installed, programmed and commissioned unit controller with all I/O capabilities and control sequences. The controls include all on-board diagnostic, safety and control features to operate the unit. Two RS485 communication ports are included as standard with one alarm output, a shutdown contact, smoke ventilation contact, analog inputs for supply air temperature and duct static pressure reset, along with a variety of other capabilities.

Standard Ambient – YPAL050-061 models operate down to 40 °F as standard.

Low Ambient – This option includes low ambient control of the first refrigerant circuit down to 0 °F through the use of discharge pressure transducer on circuit one, and condenser fan speed using a variable-frequency drive on the first condenser fan of circuit one. Mechanical cooling with circuit two is locked out below 45 °F (adjustable).

SENSOR AND THERMOSTAT AND SENSOR OPTIONS

Wall-Mount Temperature Sensor – A thermistor zone sensor for wall mounting. This zone sensor is for sensing temperature only, and does not include any setpoint adjustment features.

Programmable Thermostat – This option is for a ship-loose thermostat to interface with the Johnson Controls Series 100 unit. All models, YPAL050-061, include an interface for a 7-wire thermostat as standard.

COMMUNICATIONS

BACnet MSTP (RS-485) Communications – This communication is standard with the IPU controller and is available via optional field installed Simplicity Linc Gateway with the Simplicity Elite Controller. Communications to the unit are through a twisted pair, and the wire terminations are on the primary unit control board.

Modbus RTU Communications – This communication is standard on every Johnson Controls Series 100 unit and can be used in lieu of the BACnet communications (only one can be used at a time).

FILTER OPTIONS

Filter Options – Two-inch throwaway, cleanable MERV 8 filters in an angled rack are available. For higher filtration requirements, optional rigid filter racks are available with 2-inch MERV 8 plus 12-inch MERV 11 filters or 2-inch MERV 8 plus 12-inch MERV 14 filters. Two-inch pre-filters are included with rigid filter options. The rigid filter rack option is available without filter media where field-supplied filters are required.

OUTSIDE AIR DAMPER OPTIONS

Manual Damper – This option includes a manually adjustable outside air damper. It is manually adjustable at the unit by setting a mechanical stop between 0-100 percent.

Two-Position – This outside air damper option is controlled to two positions, opened and closed. Determination of the damper position is based on the occupancy schedule. In the occupied mode, the outside air damper is positioned to the manually configured point (set by mechanical stop). In the unoccupied mode, the damper is fully closed.

Modulating Economizer – This option includes modulating outdoor air and return air dampers that are interlocked and positioned by fully modulating, solid-state damper actuators. Control of the damper is via a standard ambient outdoor air dry bulb sensor, or optional single or comparative enthalpy controls.

Rain Hoods on Outside Air Intakes – For all options with outside air intake openings, rain hoods are provided as standard to keep moisture from entering the equipment. Rain hoods are an integral part of the unit and are rotated into place.

CO₂ Sensors – Optional carbon dioxide sensors for occupied space that operate demand ventilation control opening outside air dampers to ventilate the building. The CO₂ sensors can operate in a single or comparative control scheme.

RELIEF SYSTEM

Barometric Relief – Optional building air exhaust shall be accomplished through barometric relief dampers installed in the return air plenum. The dampers will open relative to the building pressure. The opening pressure shall be adjustable via a spring tension adjustment.

Modulating Powered Exhaust with Damper Control – This option consists of a constant-speed exhaust fan with a discharge damper that is modulated to control the flow of exhaust air. The damper control logic is based on the building static pressure setpoint within the unit controller.

Modulating Powered Exhaust with a VFD – This option consists of a VFD to modulate the speed of the exhaust fan to control the flow of exhaust air. The VFD control logic is based on the building static pressure setpoint within the unit controller.

Features and Benefits (Cont'd)

Powered Return Fan with Exhaust – This option uses SWSI plenum fan(s) to control building pressure. The fan motors are driven by a VFD to maintain a constant return plenum pressure. An exhaust hood with a modulating control damper is used to maintain building pressure via the building static pressure. The powered return fan is also available without the exhaust capabilities. For units with no exhaust capabilities, the HVAC system must provide alternate means of controlling building pressure.

SUPPLY FAN OPTIONS

DWDI Forward-Curved Supply Fan – The standard supply air blower is a forward-curved supply fan. This fan is good for medium static pressures and high airflows.

DWDI Airfoil Supply Fan – An optional airfoil blade supply fan is available on all models for higher static conditions. This option offers higher efficiency and lower sound in certain applications.

Fan Skid Isolation – The entire supply fan assembly is isolated from the unit base with one (standard) or two-inch deflection springs.

Supply and Exhaust Fan Motors – High efficiency open drip-proof (ODP) type and high efficiency total enclosed fan-cooled (TEFC) motors are available, all meeting the Energy Policy Act of 1992 (EPACT).

Supply Fan VFD and Manual Bypass – For VAV applications, VFDs are provided to modulate air flow. Optional manual bypass can also be provided to allow full airflow in the event of a VFD failure.

EVAPORATOR SECTION

Copper Fins – For more extreme climates that can aggressively attack aluminum, copper tube evaporator coils with copper fins are available. (This is not recommended for units in areas where they may be exposed to acid rain or environments where ammonia is present.)

CONDENSER FEATURES AND OPTIONS

Scroll Compressors – Reliable, efficient, trouble-free operation is the true measure of a packaged rooftop's value. That's why Johnson Controls Series 100 Packaged Air Conditioners use established scroll compressor technology to deliver dependable, economical performance in a wide range of applications. With the Johnson Controls Series 100 Packaged rooftops, you get the latest generation of compressor enhancements added to the scroll's inherent strengths. The simplicity of a hermetic scroll compressor allows the use of fewer moving parts to minimize breakdown.

Multiple Compressor Staging – Through the use of the scroll compressor, the Johnson Controls Series 100 has the ability to stage its cooling by enabling and disabling multiple single stage compressors on multiple circuits. These compressors are manifolded together in pairs on a single refrigeration circuit.

Compressor Circuiting – The Johnson Controls Series 100 is designed so that only two scroll compressors are in tandem within one refrigeration circuit. This means more reliable compressors, and less equipment down time. With multiple circuits, if a compressor should ever fail on one circuit, the other circuit will remain operational to work to maintain occupied loads. The Johnson Controls Series 100 system has two circuits in a unit.

Condenser Fan Motors – The condenser fan motors used on the Johnson Controls Series 100 unit are Totally Enclosed Air Over (TEAO) to provide maximum durability through any season.

Hot Gas Bypass – This option permits continuous, stable operation at capacities below the minimum step of unloading by introducing an artificial load on the evaporator. For models YPAL050-061, it is used on the lead circuit and standard on VAV units.

Replaceable Core Liquid Line Driers – Liquid line driers are standard on the Johnson Controls Series 100 unit. An option is provided for replaceable core driers.

Copper Fins – For more extreme climates that aggressively can attack aluminum, copper tube condenser coils with copper fins are available. (This is not recommended for units in areas where they may be exposed to acid rain or environments where ammonia is present)

Pre-Coated Fins – An epoxy-coated aluminum fin stock to guard against corrosive agents and insulate against galvanic potential. Recommended for mild seashore or industrial locations.

Post-Coated Fins – Technicoat coil-coating process used on condenser coils for seashore and other corrosive applications (with the exception of strong alkalis, oxidizers, wet bromide, chlorine and fluorine in concentrations greater than 100ppm).

Compressor Sound Blankets – Optional compressor acoustic sound blankets are available for sound sensitive applications.

ROOF CURBS

Partial perimeter roof curbs – This option includes a knock-down 14" high roof curb for use with wood nailer (by others). Roof curb supports the air handling section with a separate support under the condenser end.

CABINET FEATURES AND OPTIONS

Double-Wall Access Doors – Full-sized access doors provide easy access into the unit for routine maintenance and inspection. Solid wall liners encase insulation and prevent damage and erosion into the airstream.

Industry-leading 1,000-hour salt-spray rating, per ASTM B117, keeps unit in superior condition.

Series 100 package systems are offered with two common foot prints (standard and extended). The extended cabinet allows for left or right side discharge with hydronic heating coils. Note: Electric heat and gas are not available options for extended cabinet.

Double Wall Construction – Double-wall construction is the standard construction of the Johnson Controls Series 100 and incorporates powder coated pre-fabricated outer panels and corner post for maximum exterior surface protection.

Factory Shrink-Wrap – Johnson Controls Series 100 units are shipped from the factory with factory-applied shrink-wrap packaging. No longer does the contractor need to worry about dirt and debris clogging up condenser coils or moisture leaking into the air handler on the unit's way to the job site or rigging yard.

ACCESSORIES

Filter Switch – An optional dirty filter alarm can be provided that will activate an alarm when the filters require cleaning.

Magnahelic Filter Pressure Gauge – On units equipped with downstream filtration, a magnahelic filter gauge is included and visible on the exterior of the unit. The filter gauge measures the air pressure drop through the rigid filter bank to indicate when replacement is required.

THIS PAGE INTENTIONALLY LEFT BLANK.

Application Data

GENERAL

The Johnson Controls Series 100 air conditioning units are designed for outdoor installation. When selecting a site for installation, be guided by the following conditions:

- Unit must be installed on a level surface.
- For the outdoor location of the unit, select a place having a minimum sun exposure and an adequate supply of fresh air for the condenser.
- Also avoid locations beneath windows or between structures.
- Optional condenser coil protection should be used for seashore locations or other harsh environments.
- The unit should be installed on a roof that is structurally strong enough to support the weight of the unit with a minimum of deflection. It is recommended that the unit(s) be installed not more than 15 feet from a main support beam to provide proper structural support and to minimize the transmission of sound and vibration. Ideally, the center of gravity should be located over a structural support or building column.
- Location of unit(s) should also be away from building flue stacks or exhaust ventilators to prevent possible reintroduction of contaminated air through the outside air intakes.
- Be sure the supporting structures will not obstruct the duct, gas or wiring connections.
- Proper service clearance space of 6-feet around the perimeter of the unit, 8-feet on one side for coil servicing, and 12-feet to any adjacent units is required to eliminate cross contamination of exhaust and outdoor air, and for maintenance tasks such as coil pull and cleaning. No obstructions should be above the condensing unit section.

LOCATION

Of the many factors that can effect the location of equipment, some of the most important to consider are Structural, Acoustical and Service clearances. Proper attention should be made at the design stage to ensure proper structural support. In cases where equipment is being replaced, be aware of building design to insure support is adequate for the application.

The next most important consideration in applying roof top equipment is that of sound from the equipment. Special care should be made to keep the roof top unit away from sound sensitive areas such as conference rooms, auditoriums and executive offices and any other room that may have potential for tenant occupancy. Possible locations could be above hallways, mechanical or utility rooms.

Finally, service clearances should be maintained in design to insure safe access to the unit. Unit clearances are designed so that technicians have enough space between units, building walls, and edges of building to gain access safely. In cases where space is limited, please call your local representative for additional information.

Application Data (Cont'd)

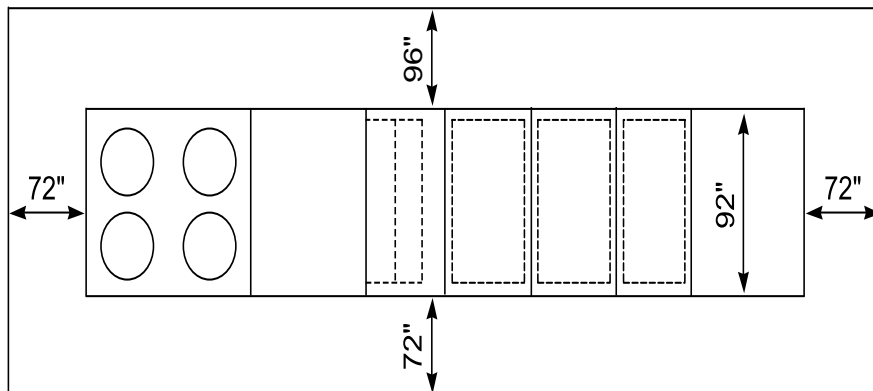

LD08044

NOTE:

1. Under certain conditions these clearances may be encroached upon. However, doing so may impact system performance.
2. This is a visual reference for all Johnson Controls Series 100 units.

FIGURE 2 - UNIT CLEARANCES

RIGGING

Proper rigging and handling of the equipment is mandatory during unloading and setting it into position to retain warranty status. Rigging and lifting should only be done by a professional rigger in accordance with a written rigging and lifting plan. The most appropriate rigging and lifting method will depend on job specific factors, such as the rigging equipment available and site needs. Therefore, a professional rigger must determine the rigging and lifting method to be used, and it is beyond the scope of this guide to specify rigging and lifting details.

Spreader bars must be used by cranes to prevent damage to the unit casing. All lifting lugs must be used when lifting the unit. Fork lifts will damage the unit and are not recommended. Care must be taken to keep the unit in the upright position during rigging and to prevent damage to the watertight seams in the unit casing. Avoid unnecessary jarring or rough handling.

UNIT PLACEMENT

- **Elevated** – Elevated roof curbs or dunnage steel can be used to support the unit in order to raise it to specific heights. When this type of placement is required, be sure to keep unit access in mind. Cat-walks or other forms of unit access may be required to one or both sides of the unit, depending on your area of the country and the local codes that are enforced. Please check with local officials to ensure the application conforms to local codes and regulations.
- **Ground Level Locations** – It is important that the units be installed on a substantial base that will not settle, causing strain on the refrigerant lines and sheet metal and resulting in possible leaks. A one-piece concrete slab with footers extended below the frost line is highly recommended. Additionally, the slab should be isolated from the main building foundation to prevent noise and vibration transmission to the building structure. For ground level installations, precautions should be taken to protect the unit from tampering by, or injury to, unauthorized persons. Erecting a fence around the unit is common practice.

- **Roof curb** – Johnson Controls offers optional roof curbs designed specifically for the Johnson Controls Series 100 footprint. This curb comes as an open condenser model and is shipped disassembled and requires field assembly and installation. For bottom supply and return openings, the curbs have matching connections to ease installation. A pipe chase that matches the unit pipe chase is also included in the curb footprint for through-the-curb utility connections. The curb should be located according to the location recommendations on *Figure 12 on page 57*, and properly sealed to prevent moisture and air leakage into and out of the duct system. Flexible collars should be used when connecting the duct work to prevent unit noise transmission and vibration into the building.

TABLE 1 - SUPPLY- AND RETURN-AIR DUCT-CONNECTION CONFIGURATIONS

UNIT CONFIGURATION		SUPPLY AIR			RETURN AIR		
		BOTTOM	LEFT	RIGHT	BOTTOM	LEFT	FRONT
50-65 TONS	Cooling only	⊙	⊙	⊙	⊙	⊙ ²	⊙ ³
	Cool/gas heat 375-750 MBH	⊙	⊙	N/A	⊙	⊙ ²	⊙ ³
	Cool/gas heat 1,125 MBH	⊙	N/A	N/A	⊙	⊙ ²	⊙ ³
	Cool/electric heat	⊙	N/A	N/A	⊙	⊙ ²	⊙ ³
	Cool / hydronic heat	⊙	⊙ ¹	⊙ ¹	⊙	⊙ ²	⊙ ³

1. Only with Ext Cab
2. Return LEFT is N/A if power return fan was selected
3. Return FRONT is N/A if there is a return fan or any exhaust option

Duct work should be supported independently of the unit.

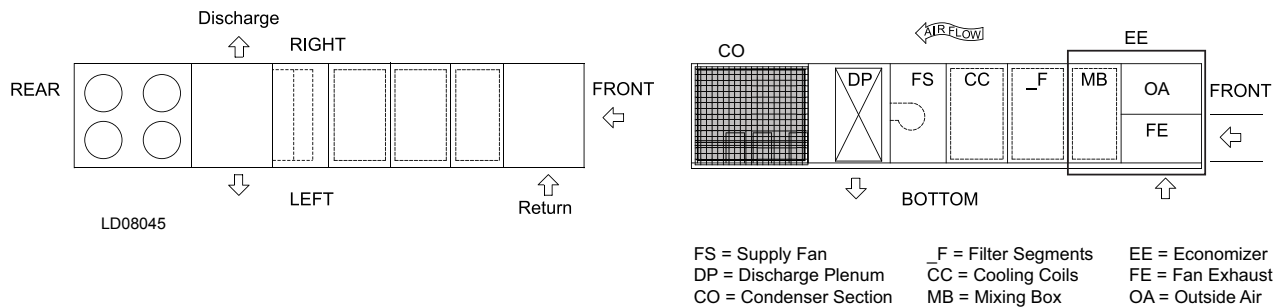

NOTE:

This diagram is provided as a visual reference of the Johnson Controls Series 100 discharge & return air openings & locations for all sizes. Please refer to the dimensional data for exact size & location of panels and openings.

FIGURE 3 - DISCHARGE AND RETURN OPENINGS

DUCT CONSIDERATIONS

Unlike competitive units where air can leave the unit stratified across the width of the unit, the Johnson Controls Series 100 unit sufficiently mixes airflow to ensure consistent air temperature from the unit. No special Tee considerations are required and the unit may be oriented either way.

UNIT ORIENTATION

For applications with multiple units located in close proximity on the roof, the orientation of the unit may be important to reduce the potential for re-entrainment of outside airflow. Regardless of the outside air and exhaust air openings on a unit, all applications can permit recirculation of exhaust air to the return, if applied improperly.

Application Data (Cont'd)

HORIZONTAL APPLICATIONS

The spectrum of applications for units in today's market is continuing to grow wider by the day. Flexibility in unit design and construction is a must in today's market in order to insure safe and sound applications of HVAC equipment. The Johnson Controls Series 100 has been designed for specific application of horizontal supply and return airflow taking the guess work out of unit application by building a unit specific to these needs. If the application calls for horizontal supply and return air, Johnson Controls can ship it from the factory as a horizontal unit. This option alleviates the need for field modification of equipment, saving time and money. The Johnson Controls Series 100 can support a left discharge on all units except 1,125 MBH gas, electric heat, steam, hot water (std. cab) or right discharge on all cooling-only units. Return air can be brought through the rear (only if return fan and any exhaust option was NOT selected) or left (only if return fan was NOT selected), making the unit specific to building needs.

ECONOMIZER

The economizer section is used for ventilation of the conditioned space to maintain indoor air quality, and also to reduce energy consumption by using outdoor air cooling in lieu of mechanical cooling. If outdoor air is appropriate for cooling, but not sufficient for the cooling demand, mechanical cooling will stage on as necessary until the cooling load is met.

Dual (comparative or differential) enthalpy operation is the most accurate and efficient means of economizer operation. The unit controller monitors the return and outside air energy content, and selects the lower of the two for operation.

VAV SUPPLY AIR PRESSURE CONTROL

Traditional packaged systems use inlet guide vanes (IGVs) for duct static pressure control. These control supply duct pressure by modulating dampers (introducing losses and inefficiencies) on the inlet of the fan, open and closed. Johnson Controls' variable frequency drives (VFDs) offer superior fan speed control and quieter, energy efficient operation.

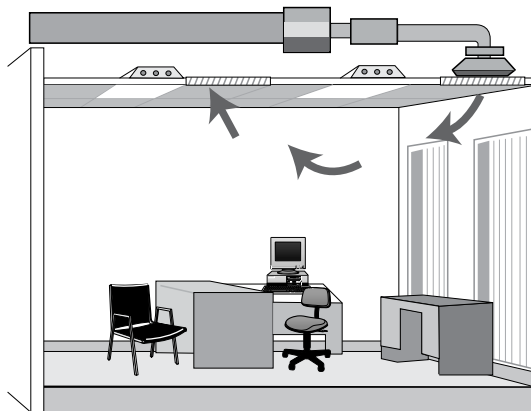

FIGURE 4 - TRADITIONAL OVERHEAD VAV AIR DELIVERY SYSTEM

For VAV applications, the Johnson Controls Series 100 unit uses a VFD to modulate fan speed and maintain a constant duct static pressure. VFDs offer superior control over the operation of the unit at part load, and offer the additional benefits of quieter and more efficient operation when compared to IGV.

FLEXSYS

The traditional approach to HVAC design in commercial buildings has been to supply conditioned air through extensive overhead duct networks to an array of diffusers spaced evenly in the ceiling. In *Figure 4 on page 18*, the conditioned air is both supplied and returned at ceiling level. Ceiling plenums must be designed large enough to accommodate the supply ducts that run through them. Return air is typically configured as ceiling plenum return without any ductwork. This type of air distribution, known as the “well-mixed” type, is the most common system in use. This conventional HVAC system is designed to promote complete mixing of supply air with room air, thereby maintaining the entire volume of all air in the space (from floor to ceiling) at the desired space setpoint temperature. In addition, to meet IAQ requirements, an adequate supply of fresh outside air must be introduced to this mix. A key disadvantage to this control strategy is that it has no provisions to accommodate different temperature preferences among the building occupants or to provide preferential ventilation in the occupied zone.

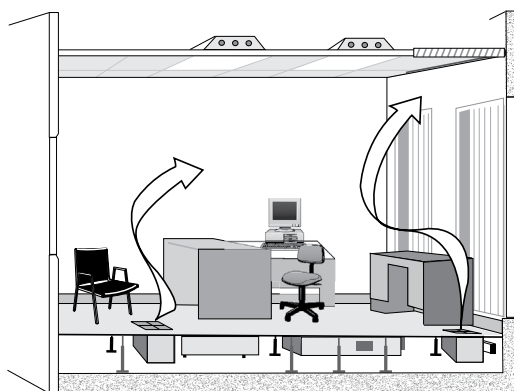

FIGURE 5 - JOHNSON CONTROLS FLEXSYS UNDERFLOOR AIR DELIVERY SYSTEM

With the Johnson Controls FlexSys Underfloor Air System, conditioned air from the rooftop unit is ducted to the underfloor plenum. As shown in *Figure 5 on page 19*, this conditioned air flows freely throughout the plenum to individual supply discharge outlets. Unlike the larger single supply duct outlets typical of overhead systems, underfloor systems are configured to have a large number of smaller supply outlets, in close proximity to the building occupants. These adjustable outlets provide an opportunity for nearby occupants to have some amount of control over thermal comfort conditions in their local environment. Air is returned from the room at ceiling level (unducted plenum return is shown). The resulting overall floor-to-ceiling air flow pattern takes advantage of the natural buoyancy produced by heat sources in the space and more efficiently removes heat loads and contaminants from the space, particularly for cooling applications. In fact, some of the most important advantages of underfloor systems over ceiling-based systems occur during cooling conditions, which are required year-round in the vast majority of interior office space in many parts of the United States.

HARSH ENVIRONMENTS – CONDENSER AND EVAPORATOR COIL PROTECTION

For harsh environmental conditions such as seashore applications, three types of coil protection are offered: copper fin material, black fin and Technicoat coatings. Johnson Controls recommends that for corrosive environments that copper fins be used to protect the evaporator and/or condenser coils. In areas where chemicals that can corrode copper are present, such as ammonia, Johnson Controls recommends that the black fin or Technicoat coating be used for maximum protection.

Application Data (Cont'd)

BUILDING PRESSURE CONTROL SYSTEMS

Building pressure control systems are often necessary when economizers are used to bring in outdoor air. Without proper building exhaust, the building may become over pressurized. The pressure control system maintains the proper building pressure by expelling the appropriate amount of air from the building.

Exhaust/Relief Fans

In this application, a powered exhaust fan may be suitable, however careful consideration of the fan type is necessary. Johnson Controls offers a centrifugal powered exhaust fan to perform this function. Some manufacturers use a propeller exhaust fan, which cannot handle the static pressure requirements.

For systems with moderate to low return static pressure, an exhaust fan is recommended. The benefit of the exhaust fan is that it does not run all of the time, and may facilitate compliance with the ASHRAE 90.1 fan motor horsepower requirement.

The exhaust fan operates in parallel with the supply fan. In this arrangement, the supply fan handles the full static pressure requirements of the system. For normal building pressure control, the exhaust fan operates to draw air from the return plenum and exhaust it out of the building.

The exhaust fan configuration is available in two forms, modulating and non-modulating. Modulating is the most common and recommended for the majority of applications, while non-modulating should be used in certain circumstances.

In the modulating exhaust system, the volume of airflow exhausted from the building is proportional to the entering volume of outside air. Control is accomplished via either a discharge damper or a variable-frequency drive (VFD). Johnson Controls recommends the use of a VFD to reduce energy consumption, sound levels and improved reliability.

In the non-modulating exhaust system, the exhaust airflow is constant whenever the exhaust fan is operating. This type of control should only be used to either assist a smoke purge system or when a system requires a constant volume of exhaust airflow.

ACOUSTICAL CONSIDERATIONS

The Johnson Controls Series 100 unit is designed for lower sound levels than competitive units by using flexible fan connections, fan spring isolators, double-wall construction, multiple fan options, and lower speed and horsepower fans. For VAV applications, VFDs are used instead of inlet guide vanes. Additional sound attenuation can be obtained using compressor sound blankets and field-supplied sound attenuators when necessary.

Even with these equipment design features, the acoustical characteristics of the entire installation must never be overlooked. Additional steps for the acoustical characteristics of an installation should be addressed during the design phase of a project to avoid costly alterations after the installation of the equipment. During the design phase of a project, the designing engineer should consider, at a minimum, the impact of the equipment location, installation, building structure, and duct work.

Physical Data

TABLE 2 - PHYSICAL DATA

MODEL	050	051	060	061
GENERAL DATA				
Length without hood (inches)	339	339	339	339
Width (inches)	92	92	92	92
Height (inches)	82	82	82	82
COMPRESSOR DATA				
Quantity	4	4	4	4
Type	Scroll	Scroll	Scroll	Scroll
Unit Capacity Steps	4	4	4	4
R410A Charge (SYS 1/2) (lb-oz)	49 / 49	49 / 49	59 / 59	59 / 59
SUPPLY FAN				
Quantity	1	1	1	1
Type	FC	FC	FC	FC
Size	28 - 28	28 - 28	28 - 28	28 - 28
Motor Size Range (HP)	10 - 25	10 - 25	10 - 25	10 - 25
Air Flow Range (CFM)	10,000 - 22,500	10,000 - 22,500	12,500 - 24,000	12,500 - 24,000
Static Pressure Range (Total) (iwg)	1.0 - 6.0	1.0 - 6.0	1.0 - 6.0	1.0 - 6.0
OPTIONAL SUPPLY FAN				
Quantity	1	1	1	1
Type	AF	AF	AF	AF
Size	28	28	28	28
Motor Size Range (HP)	10 - 40	10 - 40	10 - 40	10 - 40
Air Flow Range (CFM)	10,000 - 24,000	10,000 - 24,000	12,500 - 24,000	12,500 - 24,000
Static Pressure Range (Total) (iwg)	1.0 - 8.0	1.0 - 8.0	1.0 - 8.0	1.0 - 8.0
EXHAUST FAN				
Quantity Fans/Motors	2 / 1	2 / 1	2 / 1	2 / 1
Type	FC	FC	FC	FC
Size	18 - 18	18 - 18	18 - 18	18 - 18
Motor Size Range (HP)	5 - 15	5 - 15	5 - 15	5 - 15
Air Flow Range (CFM)	4,000 - 22,500	4,000 - 22,500	4,000 - 24,000	4,000 - 24,000
Static Pressure Range (Total) (iwg)	0.1 - 1.5	0.1 - 1.5	0.1 - 1.5	0.1 - 1.5
OPTIONAL RETURN FAN				
Quantity Fans/Motors	2 / 2	2 / 2	2 / 2	2 / 2
Type	Plenum	Plenum	Plenum	Plenum
Size	245	245	245	245
Motor Size Range (min. to max. HP)	5 - 15	5 - 15	5 - 15	5 - 15
Airflow Range (min. to max. cfm)	0 - 22,500	0 - 22,500	0 - 24,000	0 - 24,000
Static pressure range (min. to max., iwg)	0 - 3	0 - 3	0 - 3	0 - 3
EVAPORATOR COIL				
Size (square feet)	52	52	52	52
Rows/FPI	3 / 17	3 / 17	4 / 17	4 / 17
HOT GAS REHEAT COIL				
Size (square feet)	33.8	33.8	33.8	33.8
Rows/FPI	1/12	1/12	1/12	1/12
HOT WATER COIL				
Type	Fin and Tube	Fin and Tube	Fin and Tube	Fin and Tube
Material	Cu Tube, Al Fin	Cu Tube, Al Fin	Cu Tube, Al Fin	Cu Tube, Al Fin
Quantity of Coils	1	1	1	1
Tube Type	0.5"	0.5"	0.5"	0.5"
Rows (each)	2	2	2	2
Total Face Area (sq ft), Standard Cabinet	30.7 ft ²	30.7 ft ²	30.7 ft ²	30.7 ft ²
Total Face Area (sq ft), Extended Cabinet	20.1 ft ²	20.1 ft ²	20.1 ft ²	20.1 ft ²

Physical Data (Cont'd)

TABLE 2 – PHYSICAL DATA (CONT'D)

MODEL	050	051	060	061	
STEAM COIL					
Type	Fin and Tube, Distributing Type	Fin and Tube, Distributing Type	Fin and Tube, Distributing Type	Fin and Tube, Distributing Type	
Material	Cu Tube, Al Fin	Cu Tube, Al Fin	Cu Tube, Al Fin	Cu Tube, Al Fin	
Quantity of Coils	1	1	1	1	
Tube Type	1"	1"	1"	1"	
Rows (each)	1	1	1	1	
Total Face Area (sq ft), Standard Cabinet	19.8 ft ²	19.8 ft ²	19.8 ft ²	19.8 ft ²	
Total Face Area (sq ft), Extended Cabinet	31.2 ft ²	31.2 ft ²	31.2 ft ²	31.2 ft ²	
CONDENSER COIL					
Size (square feet)	88	88	88	88	
Rows/FPI	2 / 17	2 / 17	3 / 17	3 / 17	
CONDENSER FANS					
Quantity	4	4	4	4	
Type	Prop.	Prop.	Prop.	Prop.	
Diameter (inches)	36	36	36	36	
Motor HP	2	2	2	2	
FILTERS - 2 THROWAWAY (PRE-FILTER POSITION - ANGLED)					
Quantity	4 / 12	4 / 12	4 / 12	4 / 12	
Size (length x width) (in.)	12x24 / 24x24	12x24 / 24x24	12x24 / 24x24	12x24 / 24x24	
Total Filter Face Area (square feet)	56	56	56	56	
FILTERS - 2 CLEANABLE (PRE-FILTER POSITION - ANGLED)					
Quantity	4 / 12	4 / 12	4 / 12	4 / 12	
Size (length x width) (in.)	12x24 / 24x24	12x24 / 24x24	12x24 / 24x24	12x24 / 24x24	
Total Filter Face Area (square feet)	56	56	56	56	
FILTERS - 2 PLEATED, MERV 8					
Quantity	4 / 12	4 / 12	4 / 12	4 / 12	
Size (length x width) (in.)	12x24 / 24x24	12x24 / 24x24	12x24 / 24x24	12x24 / 24x24	
Total Filter Face Area (square feet)	56	56	56	56	
FILTERS - 12" MERV 11 WITH 2" MERV 8 PRE-FILTERS					
Quantity	1 / 4 / 9	1 / 4 / 9	1 / 4 / 9	1 / 4 / 9	
Size (length x width) (in.)	16x20/25x16/25x20	16x20/25x16/25x20	16x20/25x16/25x20	16x20/25x16/25x20	
Total Filter Face Area (square feet)	43.0	43.0	43.0	43.0	
FILTERS - 12" MERV 14 WITH 2" MERV 8 PRE-FILTERS					
Quantity	1 / 4 / 9	1 / 4 / 9	1 / 4 / 9	1 / 4 / 9	
Size (length x width) (in.)	16x20/25x16/25x20	16x20/25x16/25x20	16x20/25x16/25x20	16x20/25x16/25x20	
Total Filter Face Area (square feet)	43	43	43	43	
FILTERS - 2 CARBON (PRE-FILTER POSITION - ANGLED), MERV 8					
Quantity	4 / 12	4 / 12	4 / 12	4 / 12	
16x20/25x16/25x20	12x24/24x24	12x24/24x24	12x24/24x24	12x24/24x24	
Total Filter Face Area (square feet)	56	56	56	56	
FILTERS - 12 RIGID RACK ONLY, WITH 2" THROWAWAYS					
Quantity	1 / 4 / 9	1 / 4 / 9	1 / 4 / 9	1 / 4 / 9	
Size (length x width) (in.)	16x20/25x16/25x20	16x20/25x16/25x20	16x20/25x16/25x20	16x20/25x16/25x20	
Total Filter Face Area (square feet)	43	43	43	43	
GAS FURNACES					
Staged Furnace Sizes (input/output/ steps)		375 MBH / 300 MBH / 2 steps			
		750 MBH / 600 MBH / 4 steps			
		1125 MBH / 900 MBH / 6 steps			
Inlet Gas Pressure Range	Natural	4.5 - 10.5 IWC	4.5 - 10.5 IWC	4.5 - 10.5 IWC	4.5 - 10.5 IWC
	Propane	11.0 - 13.0 IWC	11.0 - 13.0 IWC	11.0 - 13.0 IWC	11.0 - 13.0 IWC

TABLE 2 – PHYSICAL DATA (CONT'D)

MODEL		050	051	060	061	
— Modulating Furnace Sizes (input/output/turndown)		375 MBH / 300 MBH / 8:1 turndown				
		750 MBH / 600 MBH / 16:1 turndown				
		1125 MBH / 900 MBH / 24:1 turndown				
— Inlet Gas Pressure Range	Natural	4.5 - 10.5 IWC	4.5 - 10.5 IWC	4.5 - 10.5 IWC	4.5 - 10.5 IWC	
	Propane	11.0 - 13.0 IWC	11.0 - 13.0 IWC	11.0 - 13.0 IWC	11.0 - 13.0 IWC	
ELECTRIC HEATERS (IPU CONTROL)		STEPS				
Volt		2	3	4	5	6
208/240			KW40		KW80	KW108
480		KW40	KW80, KW108	KW150		
ELECTRIC HEATERS (SIMPLICITY CONTROL)		STEPS				
Volt		2		3		
208/240				KW40, KW80, KW108		
480		KW40		KW80, KW108, KW150		
MINIMUM OA TEMP FOR MECH. COOLING		50°F	50°F	50°F	50°F	
LOW AMBIENT OPTION MIN. OA TEMP		0	0	0	0	
MINIMUM AIRFLOW GAS (HEATING)	375	11,500	11,500	11,500	11,500	
	750	14,000	14,000	14,000	14,000	
BOTTOM SUPPLY ONLY		1,125	18,000	18,000	18,000	18,000

TABLE 3 - PHYSICAL DATA - COMPRESSORS

MODEL		COMPRESSORS UTILIZED				COMPRESSOR NOMINAL TONS				% CAPACITY PER STAGE			
		SYSTEM 1		SYSTEM 2		SYSTEM 1		SYSTEM 2		STAGE 1		STAGE 2	
		COMPR 1A	COMPR 1B	COMPR 2A	COMPR 2B	COMPR 1A	COMPR 1B	COMPR 2A	COMPR 2B	STAGE 1	STAGE 2	STAGE 3	STAGE 4
MODEL	050	ZP120	ZP137	ZP120	ZP137	12.53	13.58	12.53	13.58	24.0	48.0	74.0	100
	051	ZP137	ZP137	ZP137	ZP137	13.58	13.58	13.58	13.58	25.0	50.0	75.0	100
	060	ZP137	ZP182	ZP137	ZP182	13.58	17.95	13.58	17.95	21.5	43.1	71.5	100
	061	ZP137	ZP182	ZP154	ZP182	13.58	17.95	14.86	17.95	21.1	44.2	72.1	100

THIS PAGE INTENTIONALLY LEFT BLANK.

Altitude and Temperature Corrections

The information below should be used to assist in application of product when being applied at altitudes at or exceeding 1000 feet above sea level.

The airflow rates listed in the standard blower performance tables are based on standard air at sea level. As the altitude or temperature increases, the density of air decreases. In order to use the indoor blower tables for high-altitude applications, certain corrections are necessary.

A centrifugal fan is a “constant-volume” device. This means that if the RPM remains constant, the CFM delivered is the same regardless of the density of the air. However, since the air at high altitude is less dense, less static pressure will be generated and less power will be required than a similar application at sea level. Air-density-correction factors are shown in *Table 4 on page 25*.

TABLE 4 - ALTITUDE-CORRECTION FACTORS

AMBIENT AIR TEMP (°F)	ALTITUDE (FEET)						
	0	1000	2000	3000	4000	5000	6000
40	1.060	1.022	0.986	0.95	0.916	0.882	0.849
50	1.039	1.002	0.966	0.931	0.898	0.864	0.832
60	1.019	0.982	0.948	0.913	0.880	0.848	0.816
70	1.000	0.964	0.930	0.896	0.864	0.832	0.801
80	0.982	0.947	0.913	0.880	0.848	0.817	0.787
90	0.964	0.929	0.897	0.864	0.833	0.802	0.772
100	0.946	0.912	0.88	0.848	0.817	0.787	0.758

The examples below will assist in determining the airflow performance of the product at altitude.

Example 1: What are the corrected CFM, static pressure, and BHP at an elevation of 5,000 ft. if the blower performance data at sea level is 6,000 CFM, 1.5 IWC and 4.0 BHP?

Solution: At an elevation of 5,000 ft, the indoor blower will still deliver 6,000 CFM if the RPM is unchanged. However, *Table 4 on page 25* must be used to determine the static pressure and BHP.

Since no temperature data is given, we will assume an air temperature of 70 °F. *Table 4 on page 25* shows the correction factor to be 0.832.

$$\text{Corrected static pressure} = 1.5 \times 0.832 = 1.248 \text{ IWC}$$

$$\text{Corrected BHP} = 4.0 \times 0.832 = 3.328$$

Example 2: A system, located at 5,000 feet of elevation, is to deliver 6,000 CFM at a static pressure of 1.5". Use the unit blower tables to select the blower speed and the BHP requirement.

Solution: As in the example above, no temperature information is given so 70°F is assumed.

Altitude and Temperature Corrections (Cont'd)

The 1.5 static pressure given is at an elevation of 5,000 ft. The first step is to convert this static pressure to equivalent sea-level conditions.

$$\text{Sea-level static pressure} = 1.5 / 0.832 = 1.80$$

Enter the blower table at 6000 CFM and static pressure of 1.8". The rpm listed will be the same rpm needed at 5,000 ft.

Suppose that the corresponding BHP listed in the blower table is 3.2.

This value must be corrected for elevation.

$$\text{BHP at 5,000 ft} = 3.2 \times .832 = 2.66$$

Cooling Performance Data — 050 Model

TABLE 5 - COOLING PERFORMANCE DATA* - 50 TON

AIR ON EVAPO-RATOR COIL		TEMPERATURE OF AIR ON CONDENSER COIL																	
		85°F									95°F								
		TOTAL COOLING CAP. (MBH)	TOTAL INPUT (KW)	SENSIBLE COOLING CAPACITY (MBH)								TOTAL COOLING CAP. (MBH)	TOTAL INPUT (KW)	SENSIBLE COOLING CAPACITY (MBH)					
ENTERING DRY BULB (°F)								ENTERING DRY BULB (°F)											
CFM	WB (°F)			86	83	80	77	74	71	68			86	83	80	77	74	71	68
12000	73	684	45	402	364	324	287	247	-	-	653	50	390	352	312	275	235	-	-
	67	618	44	485	446	407	368	329	289	249	590	49	471	433	394	355	317	277	237
	62	574	43	562	520	476	437	397	358	318	550	48	549	508	465	423	384	345	305
	56	571	43	571	555	539	523	484	442	400	550	47	550	534	518	502	471	428	386
14000	73	702	45	428	385	341	296	252	-	-	670	50	415	372	329	284	240	-	-
	67	636	44	523	479	434	390	345	299	254	608	49	514	466	421	377	332	287	241
	62	604	44	604	568	518	469	424	378	333	581	48	581	555	506	456	410	365	320
	56	603	43	603	586	568	551	526	476	427	581	48	581	563	546	529	511	463	413
16000	73	716	46	452	404	355	305	255	-	-	683	50	439	391	343	292	243	-	-
	67	652	45	565	510	460	410	360	309	258	623	49	555	497	447	397	347	296	245
	62	632	44	632	612	559	500	448	397	346	607	48	607	589	545	489	435	384	333
	56	631	44	631	612	593	575	556	511	453	606	48	606	588	569	551	533	498	441
18000	73	728	46	475	421	368	312	258	-	-	694	50	462	409	355	300	246	-	-
	67	666	45	605	539	484	429	374	317	261	636	49	594	531	471	415	360	304	248
	62	655	44	655	635	596	533	472	415	359	629	49	629	610	583	521	458	402	345
	56	654	44	654	634	614	595	575	544	481	629	48	629	609	589	570	551	529	466
20000	73	737	46	496	438	380	320	260	-	-	702	50	483	425	367	307	248	-	-
	67	679	45	646	574	507	446	386	325	264	649	49	633	560	493	433	373	311	251
	62	675	44	675	654	632	564	494	432	370	648	49	648	628	607	552	480	418	357
	56	674	44	674	653	632	612	592	572	506	647	49	648	627	607	586	567	547	492
22000	73	744	46	516	453	391	326	262	-	-	709	51	503	440	378	313	250	-	-
	67	692	45	682	604	528	463	398	334	266	665	49	665	592	514	449	385	320	253
	62	692	45	692	670	649	594	515	448	381	665	49	665	643	622	581	506	434	367
	56	691	45	691	670	648	627	606	585	531	664	49	664	643	621	601	580	560	518
24000	73	751	46	535	468	401	332	264	-	-	715	51	521	454	388	319	252	-	-
	67	708	45	708	637	548	478	409	340	269	680	50	680	626	534	465	396	327	256
	62	707	44	708	685	663	624	540	463	391	679	49	679	657	635	610	526	449	377
	56	707	44	707	684	662	640	618	597	555	678	49	678	656	635	613	592	571	541
		105°F									115°F								
12000	73	619	55	376	338	299	261	222	-	-	580	61	360	323	285	246	207	-	-
	67	558	54	457	418	380	341	303	263	223	524	60	444	403	364	326	287	248	209
	62	526	53	526	493	450	409	369	330	291	499	59	499	478	436	393	354	314	275
	56	526	53	526	510	494	478	456	413	371	499	59	499	483	468	453	438	398	355
14000	73	634	55	401	358	315	270	226	-	-	594	61	386	343	300	255	211	-	-
	67	575	54	499	451	407	362	318	273	228	540	60	486	435	391	347	302	257	212
	62	555	53	555	538	492	443	395	350	305	526	59	527	510	477	427	379	334	289
	56	555	53	555	538	521	504	487	449	398	526	59	526	509	493	476	460	433	384
16000	73	646	55	425	377	329	278	229	-	-	604	61	409	361	313	263	214	-	-
	67	589	54	540	486	432	382	332	281	231	553	60	527	470	416	366	316	266	215
	62	580	53	580	561	532	474	420	369	318	549	59	549	531	514	460	403	353	302
	56	579	53	579	561	543	525	507	483	426	548	59	548	531	513	496	478	461	411
18000	73	655	56	447	394	341	286	232	-	-	613	62	431	378	325	270	216	-	-
	67	603	55	580	516	455	400	346	289	234	568	60	565	503	439	384	329	273	219
	62	600	54	600	581	562	507	443	403	330	568	60	568	549	531	492	429	370	314
	56	600	54	600	580	561	543	524	519	452	567	60	567	549	530	512	494	476	436
20000	73	663	56	468	410	353	293	234	-	-	619	62	452	394	337	277	219	-	-
	67	618	55	618	548	478	418	358	298	237	585	60	585	534	461	401	342	282	221
	62	618	54	618	598	578	538	468	403	341	584	60	584	565	545	522	451	386	325
	56	617	54	617	597	577	558	538	519	478	584	60	584	564	545	526	507	488	461
22000	73	669	56	488	425	363	299	236	-	-	625	62	471	409	347	283	221	-	-
	67	634	55	634	679	499	434	370	305	239	599	61	599	568	488	417	353	289	223
	62	634	54	633	612	592	567	490	418	352	598	60	598	578	558	538	476	401	335
	56	633	54	633	612	591	571	551	531	502	598	60	598	577	557	538	518	499	480
24000	73	674	56	506	439	373	308	238	-	-	629	62	489	423	357	292	223	-	-
	67	647	55	647	614	526	449	380	312	241	611	61	611	590	514	433	364	295	225
	62	647	55	647	625	604	583	514	433	362	611	61	610	590	569	549	498	416	345
	56	646	55	646	625	603	582	561	540	521	610	61	610	589	568	548	528	508	489

* Rated performance is at sea level. Cooling capacities are gross cooling capacity.

Cooling Performance Data — 051 Model

TABLE 6 - COOLING PERFORMANCE DATA* - 55 TON

AIR ON EVAPO-RATOR COIL		TEMPERATURE OF AIR ON CONDENSER COIL																	
		85°F									95°F								
		TOTAL COOLING CAP. (MBH)	TOTAL INPUT (KW)	SENSIBLE COOLING CAPACITY (MBH)								TOTAL COOLING CAP. (MBH)	TOTAL INPUT (KW)	SENSIBLE COOLING CAPACITY (MBH)					
ENTERING DRY BULB (°F)								ENTERING DRY BULB (°F)											
CFM	WB (°F)			86	83	80	77	74	71	68			86	83	80	77	74	71	68
12000	73	704	48	413	374	334	295	255	-	-	672	53	400	361	321	283	242	-	-
	67	636	47	496	457	417	378	338	298	257	607	51	483	443	404	365	325	285	244
	62	590	46	572	531	487	447	407	367	327	564	51	559	516	475	434	394	354	313
	56	584	45	584	568	551	535	-	-	-	562	50	562	546	530	514	480	438	395
14000	73	723	48	441	396	351	305	259	-	-	690	53	427	383	338	293	247	-	-
	67	655	47	537	492	446	401	355	309	262	624	52	523	478	433	387	342	296	249
	62	619	46	619	579	530	481	435	389	342	595	51	595	565	515	467	421	375	329
	56	618	46	618	600	582	565	537	487	439	594	51	594	577	559	542	522	474	424
16000	73	738	48	467	417	366	315	263	-	-	704	53	454	404	353	302	250	-	-
	67	672	47	580	525	474	423	371	319	266	640	52	566	511	460	409	358	305	252
	62	647	47	647	625	571	514	462	409	357	622	51	622	603	557	502	448	395	343
	56	646	46	646	627	608	589	571	522	466	621	51	621	602	584	565	547	508	451
18000	73	750	49	492	436	381	323	266	-	-	715	53	479	423	367	310	253	-	-
	67	686	47	621	557	501	443	386	328	269	656	52	606	543	487	429	372	314	256
	62	671	47	671	651	611	548	487	429	370	645	51	645	625	596	533	473	415	356
	56	670	47	670	650	630	610	590	556	494	644	51	644	624	604	585	566	541	479
20000	73	760	49	516	455	394	331	269	-	-	724	54	503	442	381	318	256	-	-
	67	699	48	660	593	526	463	400	336	272	667	52	647	578	512	449	386	322	259
	62	692	47	692	671	646	581	511	447	383	664	52	664	644	623	565	497	433	369
	56	691	47	691	670	649	628	608	586	519	664	52	664	643	622	602	582	562	506
22000	73	768	49	539	473	407	339	272	-	-	731	54	526	460	393	326	259	-	-
	67	711	48	698	622	550	482	414	344	275	681	52	681	611	536	468	400	332	262
	62	710	47	710	688	666	610	534	465	395	682	52	682	660	638	597	519	451	381
	56	709	47	709	687	665	644	622	601	546	681	52	681	659	637	616	596	575	531
24000	73	775	49	561	490	419	346	274	-	-	737	54	547	477	405	333	261	-	-
	67	726	48	726	655	573	500	427	353	278	697	53	697	642	558	486	413	339	265
	62	726	47	726	703	680	640	556	482	407	697	52	697	674	652	625	546	468	393
	56	725	47	725	702	680	657	635	613	570	696	52	696	673	651	629	608	586	554
		105°F									115°F								
12000	73	636	58	385	347	307	268	228	-	-	597	64	370	331	293	253	213	-	-
	67	574	57	467	429	389	350	311	270	230	539	63	454	412	373	334	295	255	214
	62	539	56	539	502	460	418	379	339	299	511	62	511	486	445	402	362	323	283
	56	538	56	538	522	506	490	464	422	380	510	62	510	495	479	464	448	406	364
14000	73	653	58	413	368	324	278	232	-	-	611	65	397	352	308	263	217	-	-
	67	592	57	511	463	418	373	327	281	235	555	63	496	446	401	356	311	265	218
	62	569	56	569	549	501	452	406	360	314	539	63	539	522	485	437	389	343	297
	56	568	56	568	550	533	516	499	458	408	538	62	538	521	505	488	472	442	393
16000	73	665	59	439	389	339	287	236	-	-	622	65	422	373	323	271	220	-	-
	67	606	57	553	495	445	394	343	290	238	569	64	537	482	428	377	326	274	222
	62	594	57	594	575	542	486	432	380	328	562	63	562	544	524	471	415	363	311
	56	593	57	593	574	556	538	520	493	437	561	63	561	543	526	508	491	473	421
18000	73	675	59	464	408	353	296	239	-	-	631	65	447	392	336	280	223	-	-
	67	619	58	592	531	471	414	357	299	241	583	64	576	516	454	397	341	283	225
	62	615	57	615	596	576	519	457	399	341	582	63	582	563	544	503	439	382	324
	56	614	57	614	595	576	556	538	519	464	581	63	581	562	543	525	507	489	448
20000	73	683	59	487	427	366	303	242	-	-	638	65	471	410	349	287	226	-	-
	67	633	58	630	565	496	434	371	307	244	599	64	599	549	478	417	354	292	228
	62	633	57	633	613	593	550	480	417	353	599	64	599	579	559	533	466	400	336
	56	633	57	633	612	592	572	553	533	490	598	64	598	578	559	539	520	501	472
22000	73	690	59	510	444	378	311	244	-	-	644	65	493	428	362	295	228	-	-
	67	650	58	650	597	519	452	384	316	247	614	64	614	581	506	435	367	300	231
	62	649	58	649	628	607	579	507	435	365	613	64	613	593	572	552	491	417	348
	56	649	58	649	627	607	586	565	545	514	613	64	613	592	572	552	532	513	493
24000	73	695	59	532	461	390	318	246	-	-	649	66	515	444	374	303	231	-	-
	67	664	58	664	626	547	470	397	324	249	627	64	627	605	533	453	380	307	233
	62	663	58	663	641	620	598	528	452	377	626	64	626	605	584	563	515	434	359
	56	663	58	663	641	619	598	577	556	534	625	64	625	604	583	563	542	522	502

* Rated performance is at sea level. Cooling capacities are gross cooling capacity.

Cooling Performance Data — 060 Model

TABLE 7 - COOLING PERFORMANCE DATA* - 60 TON

AIR ON EVAPO-RATOR COIL		TEMPERATURE OF AIR ON CONDENSER COIL																	
		85°F								95°F									
		TOTAL COOLING CAP. (MBH)	TOTAL INPUT (KW)	SENSIBLE COOLING CAPACITY (MBH)								TOTAL COOLING CAP. (MBH)	TOTAL INPUT (KW)	SENSIBLE COOLING CAPACITY (MBH)					
ENTERING DRY BULB (°F)								ENTERING DRY BULB (°F)											
CFM	WB (°F)			86	83	80	77	74	71	68			86	83	80	77	74	71	68
12000	73	802	55	456	416	375	336	295	-	-	768	60	441	402	361	322	281	-	-
	67	722	53	539	499	459	419	379	338	296	691	59	524	484	444	404	364	323	282
	62	664	52	612	571	529	488	448	407	366	636	57	598	556	514	473	433	392	352
	56	644	51	644	626	-	-	-	-	-	621	57	621	604	586	-	-	-	-
14000	73	830	55	486	441	394	348	301	-	-	793	61	471	426	380	333	286	-	-
	67	749	54	583	537	491	445	398	351	303	715	59	568	522	476	429	383	336	288
	62	692	53	671	622	572	525	478	431	384	663	58	656	606	559	510	463	416	369
	56	685	52	685	666	646	627	578	530	480	660	57	660	641	622	603	563	514	465
16000	73	852	56	515	464	412	359	306	-	-	813	61	500	449	397	344	291	-	-
	67	769	54	625	573	521	469	416	362	308	736	59	613	558	505	453	401	347	293
	62	722	53	722	672	616	560	507	454	401	695	58	695	656	602	544	491	438	385
	56	721	52	721	700	679	658	623	566	510	694	58	694	673	653	633	607	551	494
18000	73	869	56	543	486	428	369	310	-	-	828	61	528	470	413	354	295	-	-
	67	788	54	670	608	550	491	433	373	313	751	60	654	592	534	476	417	357	297
	62	752	53	752	720	658	594	535	475	416	724	59	724	702	643	581	519	460	400
	56	751	53	751	729	707	685	663	602	539	723	58	723	701	679	658	637	587	522
20000	73	883	56	570	507	444	379	313	-	-	841	62	554	491	428	363	298	-	-
	67	804	55	714	642	578	514	449	383	316	766	60	697	628	562	497	433	367	301
	62	779	54	779	755	699	630	562	496	430	749	59	749	726	683	613	545	480	414
	56	778	53	778	754	731	708	685	638	569	748	59	748	725	702	680	657	622	552
22000	73	894	57	596	527	458	388	317	-	-	852	62	580	511	443	372	301	-	-
	67	816	55	753	680	605	535	464	392	320	780	60	738	663	589	518	448	376	304
	62	803	54	803	778	739	663	588	516	444	772	59	771	747	721	648	571	500	428
	56	802	54	802	777	753	728	705	672	595	771	59	770	746	722	699	676	652	580
24000	73	904	57	621	547	472	396	320	-	-	860	62	605	531	456	380	304	-	-
	67	831	55	796	712	631	555	479	402	323	793	60	778	698	614	539	462	386	308
	62	824	54	824	798	772	696	612	535	457	791	60	791	766	741	680	595	519	441
	56	823	54	823	797	771	746	722	697	623	790	60	790	765	740	716	692	668	608
		105°F								115°F									
12000	73	730	66	425	386	345	306	265	-	-	688	74	408	369	329	289	249	-	-
	67	657	65	508	468	428	388	348	308	266	619	72	490	450	411	371	331	291	250
	62	604	64	581	539	497	457	417	376	336	571	71	564	522	481	439	399	359	319
	56	596	63	596	579	562	543	501	458	417	568	70	568	552	535	519	484	442	400
14000	73	753	67	455	410	364	318	271	-	-	709	74	437	392	347	300	254	-	-
	67	678	65	550	505	459	413	367	320	272	640	72	535	487	441	395	349	302	255
	62	634	64	634	590	541	493	446	400	353	604	71	604	572	524	475	428	382	335
	56	633	64	633	614	596	577	546	497	448	603	71	603	585	567	549	528	479	430
16000	73	770	67	483	432	381	328	275	-	-	724	74	465	414	363	311	258	-	-
	67	697	66	595	540	488	436	384	330	277	657	73	579	522	470	418	366	313	259
	62	665	64	666	639	584	527	474	421	368	633	72	633	614	566	511	456	403	350
	56	664	64	664	644	624	605	585	533	477	632	71	632	613	593	574	555	516	460
18000	73	784	68	511	453	396	338	278	-	-	737	75	492	435	378	320	261	-	-
	67	713	66	639	574	517	458	400	341	281	671	73	621	559	498	440	382	323	263
	62	693	65	693	671	626	563	501	442	383	658	72	658	638	607	546	483	424	365
	56	692	65	692	670	649	628	608	570	507	657	72	657	637	616	596	576	551	488
20000	73	796	68	537	474	411	347	282	-	-	747	75	519	456	393	329	264	-	-
	67	727	66	681	612	544	480	416	350	284	684	73	662	592	525	461	397	332	267
	62	716	65	716	694	665	597	527	462	397	680	72	680	658	637	580	508	444	378
	56	715	65	715	693	671	649	627	603	535	679	72	679	657	636	615	594	573	516
22000	73	805	68	563	494	425	355	285	-	-	755	75	544	476	407	337	268	-	-
	67	741	66	722	648	571	501	431	360	288	700	73	700	628	551	482	412	342	270
	62	737	65	737	713	690	631	552	482	410	699	73	699	677	654	612	537	463	391
	56	736	65	736	713	689	666	644	621	562	698	73	699	676	653	631	609	587	544
24000	73	813	68	588	513	439	363	287	-	-	762	75	569	495	421	345	270	-	-
	67	756	67	756	679	596	521	445	369	291	717	74	717	662	582	502	426	350	272
	62	755	66	755	731	707	663	581	501	423	716	73	716	693	669	642	562	482	404
	56	754	66	755	730	706	682	659	635	590	715	73	715	692	668	646	623	600	569

* Rated performance is at sea level. Cooling capacities are gross cooling capacity.

Cooling Performance Data — 061 Model

TABLE 8 - COOLING PERFORMANCE DATA* - 65 TON

AIR ON EVAPO-RATOR COIL		TEMPERATURE OF AIR ON CONDENSER COIL																	
		85°F									95°F								
		TOTAL COOLING CAP. (MBH)	TOTAL INPUT (KW)	SENSIBLE COOLING CAPACITY (MBH)								TOTAL COOLING CAP. (MBH)	TOTAL INPUT (KW)	SENSIBLE COOLING CAPACITY (MBH)					
ENTERING DRY BULB (°F)								ENTERING DRY BULB (°F)											
CFM	WB (°F)			86	83	80	77	74	71	68			86	83	80	77	74	71	68
12000	73	815	56	461	421	381	341	300	-	-	780	62	446	407	366	327	286	-	-
	67	733	55	544	504	464	424	384	343	301	702	60	529	489	449	409	369	328	287
	62	673	53	618	576	534	493	453	412	371	645	59	602	561	519	478	438	397	357
	56	651	52	651	-	-	-	-	-	-	629	58	629	611	-	-	-	-	-
14000	73	844	57	492	446	399	354	306	-	-	806	62	477	431	385	339	291	-	-
	67	760	55	589	543	496	450	404	356	308	727	61	573	527	481	435	388	341	293
	62	702	54	676	627	577	531	484	437	389	673	59	661	612	563	515	468	421	374
	56	693	53	694	674	654	-	-	-	-	669	59	669	649	630	611	568	519	470
16000	73	866	57	521	470	418	365	311	-	-	827	63	505	454	403	350	296	-	-
	67	782	56	631	579	527	474	422	368	314	747	61	617	563	511	458	406	352	298
	62	731	54	730	678	622	566	513	459	406	704	60	704	661	606	550	497	444	390
	56	730	54	730	708	687	667	628	571	516	703	59	703	682	662	641	612	556	500
18000	73	884	58	549	492	434	375	316	-	-	843	63	533	476	419	360	300	-	-
	67	801	56	676	614	556	497	438	379	318	764	61	659	598	540	481	423	363	303
	62	762	55	762	726	664	600	541	481	421	734	60	734	708	648	585	524	465	405
	56	761	54	761	738	716	694	670	608	544	733	60	733	710	689	667	646	592	528
20000	73	898	58	576	513	450	385	319	-	-	856	64	560	497	434	369	304	-	-
	67	817	56	718	648	584	519	455	389	322	779	62	703	633	567	503	438	373	306
	62	790	55	790	766	705	636	567	502	436	760	60	760	736	688	619	551	485	420
	56	789	55	789	765	741	718	694	644	573	759	60	759	735	712	689	667	628	557
22000	73	910	58	602	533	464	394	323	-	-	867	64	586	517	448	378	307	-	-
	67	831	56	760	683	611	541	470	398	326	793	62	744	669	594	524	454	382	310
	62	814	55	814	789	745	669	594	522	450	782	61	782	758	727	653	576	505	433
	56	813	55	813	788	763	739	714	678	601	781	61	781	757	733	709	685	659	585
24000	73	920	59	628	553	479	402	326	-	-	876	64	611	537	462	386	310	-	-
	67	844	57	801	718	638	561	485	407	329	806	62	784	703	620	545	468	391	313
	62	836	56	836	809	780	702	618	541	463	803	61	803	777	752	685	601	524	446
	56	835	56	835	808	783	757	732	706	629	802	61	802	776	751	726	702	678	613
		105°F									115°F								
12000	73	742	68	430	391	350	311	270	-	-	701	76	413	374	334	294	254	-	-
	67	667	66	513	473	433	393	353	312	271	630	74	495	456	416	376	336	296	255
	62	614	65	586	544	502	462	422	381	341	581	73	569	527	486	445	404	364	324
	56	604	64	604	587	569	-	-	-	-	577	72	577	560	543	527	489	447	405
14000	73	766	69	460	415	369	323	276	-	-	722	76	442	397	352	306	259	-	-
	67	690	67	556	510	464	418	372	325	277	651	74	539	492	446	401	354	307	260
	62	643	66	641	595	547	498	451	405	358	613	73	613	577	529	480	434	387	340
	56	641	65	642	623	604	585	551	502	453	612	72	612	594	575	557	534	484	435
16000	73	784	69	489	437	386	333	280	-	-	738	77	471	420	368	316	263	-	-
	67	710	67	601	546	494	442	389	336	282	669	75	583	527	476	424	371	318	264
	62	675	66	675	644	589	532	480	427	373	643	73	643	622	571	517	462	409	356
	56	674	66	674	653	633	613	593	539	482	642	73	642	622	603	583	564	521	465
18000	73	799	70	516	459	402	343	284	-	-	751	77	498	441	384	325	266	-	-
	67	726	68	644	580	522	464	405	346	286	683	75	626	563	504	446	387	328	268
	62	703	66	703	681	631	568	507	448	388	668	74	669	648	613	550	488	429	370
	56	702	66	702	680	659	638	617	575	512	668	74	668	647	626	606	585	556	493
20000	73	810	70	543	480	417	352	287	-	-	762	77	524	461	399	334	269	-	-
	67	739	68	685	618	550	485	421	355	289	697	75	667	598	531	467	403	337	272
	62	727	67	727	704	671	602	533	468	402	691	74	691	669	646	585	514	449	384
	56	726	67	726	703	681	658	636	609	540	690	74	690	668	646	625	604	583	522
22000	73	820	70	568	500	431	361	290	-	-	770	77	550	481	412	343	273	-	-
	67	753	68	727	652	576	506	436	365	293	711	75	706	634	557	488	417	346	275
	62	748	67	748	724	700	636	558	487	416	711	75	711	688	665	617	542	469	397
	56	747	67	747	723	700	677	654	631	567	710	75	710	687	664	641	619	598	549
24000	73	828	70	593	519	445	369	293	-	-	778	78	574	500	426	351	276	-	-
	67	768	68	764	685	602	527	451	374	296	729	76	729	668	585	507	432	356	278
	62	767	68	767	742	718	668	587	506	429	728	75	728	704	680	648	567	487	410
	56	766	68	766	741	717	693	669	645	595	727	75	727	703	680	656	633	611	575

* Rated performance is at sea level. Cooling capacities are gross cooling capacity.

Heating Performance Data — Gas/Electric Heat/Hot Water Coil/ Steam Coil

GAS HEATING

TABLE 9 - STAGED AND MODULATING NATURAL GAS HEAT PERFORMANCE DATA

STAGED AND MODULATING NATURAL GAS HEAT						STAGED NATURAL GAS HEAT	MODULATING NATURAL GAS HEAT
MODEL	GAS INPUT CAPACITY (MBH)	MAXIMUM OUTPUT CAPACITY (MBH)	MINIMUM AIR FLOW (CFM)	TEMP. RISE (°F) MIN-MAX	GAS CONNECTION SIZE	STEPS (Nb.)	TURNDOWN
50-61	375	300	11,500	15-25	1.5" MPT	2	8:1
	750	600	14,000	20-30		4	16:1
	1125	900	18,000	35-45		6	24:1

ELECTRIC HEATING

TABLE 10 - ELECTRIC HEAT PERFORMANCE DATA

MODEL	SIZE (KW)	HEAT CAPACITY (MBH)	MINIMUM AIR FLOW (CFM)	MAXIMUM TEMPERATURE RISE (°F)
50-61	40	137	4,000	31.5
	80	273	6,600	38.1
	108	369	8,000	42.5
	150	512	9,600	49.1

HOT WATER COIL HEATING

TABLE 11 - HOT WATER COIL HEAT PERFORMANCE DATA

MODEL	TYPE OF COIL	FLOW/ EWT (GPM/°F)	STANDARD CABINET HEATING CAPACITY (MBH) MIN/MAX	EXTENDED CABINET HEATING CAPACITY (MBH) MIN/MAX	AIR FLOW (CFM) MIN/MAX	MAXIMUM ENTERING WATER TEMPERATURE (°F)
50	Fin and Tube	30/180	430.6/681.6	556.0/981.8	10,000-22,500	200
51			430.6/681.6	556.0/981.8	10,000-22,500	
60			475.1/695.5	628.4/1088.2	12,500-24,000	
61			475.1/695.5	628.4/1088.2	12,500-24,000	

STEAM COIL HEATING

TABLE 12 - STEAM COIL HEAT PERFORMANCE DATA

MODEL	ENTERING DB TEMP (°F)/STEAM PRESSURE (PSI)	STANDARD CABINET HEATING CAPACITY (MBH) MIN/MAX	EXTENDED CABINET HEATING CAPACITY (MBH) MIN/MAX	AIR FLOW (CFM) MIN/MAX	MAXIMUM STEAM PRESSURE (PSI)
50	70/3	319.7/655.8	414.0/885.2	10,000-22,500	10
51		319.7/655.8	414.0/885.2	10,000-22,500	
60		349.5/669.2	456.6/905.8	12,500-24,000	
61		349.5/669.2	456.6/905.8	12,500-24,000	

Component Static Pressure Drops

TABLE 13 - COMPONENT STATIC PRESSURE DROPS 050-061 MODELS

COMPONENT	SCFM							
	10,000	12,000	14,000	16,000	18,000	20,000	22,000	24,000
EVAP COIL MODELS 50 & 51								
Dry	0.19	0.21	0.24	0.27	0.31	0.36	0.40	0.46
Wet	0.24	0.27	0.31	0.35	0.39	0.44	0.50	0.57
EVAP COIL MODELS 60 & 61								
Dry	0.25	0.28	0.32	0.37	0.42	0.47	0.54	0.61
Wet	0.32	0.36	0.41	0.46	0.52	0.59	0.67	0.76
HOT GAS REHEAT COIL								
HGRH Coil	0.09	0.11	0.14	0.17	0.21	0.25	0.31	0.38
RETURN AIR								
Bottom	0.05	0.07	0.09	0.12	0.15	0.18	0.22	0.27
Side	0.09	0.13	0.18	0.23	0.30	0.37	0.44	0.53
Rear	0.04	0.06	0.08	0.10	0.12	0.15	0.19	0.22
FILTERS								
2" Throwaway	0.06	0.08	0.10	0.12	0.14	0.16	0.19	0.22
2" Cleanable	0.01	0.02	0.03	0.04	0.05	0.06	0.07	0.09
2" Pleated, MERV 8	0.06	0.08	0.10	0.12	0.14	0.16	0.19	0.21
2" Carbon, MERV 8	0.12	0.15	0.18	0.21	0.24	0.28	0.31	0.34
Rigid Filter Track - w/ 2" Throwaway (only)	0.08	0.11	0.14	0.17	0.20	0.23	0.27	0.31
12" MERV 11 - w/ 2" MERV 8 Prefilters	0.20	0.25	0.31	0.37	0.43	0.50	0.58	0.65
12" MERV 14 - w/ 2" MERV 8 Prefilters	0.31	0.38	0.46	0.55	0.64	0.74	0.84	0.94
Final Filter 12" MERV 14	0.26	0.32	0.38	0.44	0.51	0.59	0.67	0.75

TABLE 13 - COMPONENT STATIC PRESSURE DROPS 050-061 MODELS (CONT'D)

COMPONENT	SCFM							
	10,000	12,000	14,000	16,000	18,000	20,000	22,000	24,000
OUTSIDE AIR								
Standard Outside Air Damper & Hoods w/ 1" Cleanable Filters	0.13	0.18	0.25	0.34	0.43	0.53	0.64	0.77
Low Leak Outside Air Damper & Hoods w/ 1" Cleanable Filters	0.12	0.18	0.25	0.33	0.41	0.52	0.63	0.75
RETURN AIR DAMPER								
Bottom & Rear	0.05	0.07	0.10	0.12	0.16	0.19	0.24	0.28
EXHAUST AIR DAMPER								
Powered Exhaust	0.02	0.03	0.04	0.05	0.07	0.08	0.10	0.12
DISCHARGE OPENING								
Side	0.04	0.06	0.09	0.11	0.14	0.17	0.21	0.25
Bottom	0.05	0.07	0.09	0.12	0.15	0.18	0.22	0.27
GAS HEAT								
375 MBH	0.03	0.05	0.06	0.08	0.11	0.13	0.16	0.19
750 MBH	0.05	0.07	0.10	0.13	0.16	0.20	0.24	0.29
1125 MBH	0.05	0.07	0.10	0.13	0.17	0.21	0.25	0.30
ELECTRIC HEAT								
40 kW	0.01	0.01	0.02	0.02	0.02	0.03	0.04	0.04
80 kW	0.01	0.02	0.03	0.04	0.05	0.06	0.07	0.08
108 kW	0.02	0.03	0.04	0.05	0.07	0.08	0.10	0.12
150 kW	0.03	0.04	0.05	0.07	0.09	0.11	0.13	0.15
HOT WATER/STEAM COIL HEAT								
Hot Water	0.11	0.15	0.19	0.24	0.29	0.34	0.40	0.47
Steam	0.10	0.14	0.18	0.22	0.27	0.32	0.37	0.44

Supply Fan Data

TABLE 14 - 28 X 28 FORWARD-CURVED FAN

TOTAL STATIC PRESSURE (INCHES OF WATER COLUMN)																		
SCFM	1.0		1.5		2.0		2.5		3.0		3.5		4.0		4.5		5.0	
	BHP	RPM	BHP	RPM	BHP	RPM	BHP	RPM	BHP	RPM	BHP	RPM	BHP	RPM	BHP	RPM	BHP	RPM
10,000	3.3	372																
11,000	3.7	373																
12,000	4.1	377	6.0	455														
13,000	4.7	382	6.5	456	8.8	526												
14,000	5.2	388	7.1	459	9.4	526												
15,000	5.9	396	7.8	463	10.0	527	12.6	588										
16,000	6.6	405	8.6	468	10.7	529	13.4	588	16.2	644								
17,000	7.4	415	9.5	475	11.7	533	14.2	589	17.1	644								
18,000	8.3	425	10.4	482	12.7	538	15.1	592	18.0	645	21.2	695						
19,000	9.3	436	11.4	491	13.9	544	16.3	595	19.0	646	22.2	696	25.6	743				
20,000	10.4	448	12.5	500	15.0	551	17.6	600	20.3	649	23.3	697	26.8	744	30.4	788		
21,000	11.6	459	13.7	510	16.3	559	19.0	606	21.7	653	24.6	699	28.0	745	31.7	789	35.5	831
22,000	12.8	471	15.1	520	17.6	567	20.5	613	23.3	658	26.2	703	29.4	746	33.0	789	36.9	831
23,000	14.2	483	16.6	531	19.1	576	22.0	621	25.0	664	28.0	707	31.0	749	34.5	791	38.4	832
24,000	15.7	496	18.2	542	20.7	586	23.6	629	26.7	671	19.8	712	32.9	753	36.3	793	40.0	833

TABLE 15 - 28 AIRFOIL FAN

TOTAL STATIC PRESSURE (INCHES OF WATER COLUMN)																			
SCFM	1.0		1.5		2.0		2.5		3.0		3.5		4.0		4.5		5.0		
	BHP	RPM	BHP	RPM	BHP	RPM	BHP	RPM	BHP	RPM	BHP	RPM	BHP	RPM	BHP	RPM	BHP	RPM	
10,000									7.9	975	9.3	1039	10.8	1101	12.3	1160	13.9	1216	
11,000									8.7	995	10.1	1057	11.6	1116	13.2	1173	14.9	1228	
12,000								8.0	955	9.5	1018	11.0	1077	12.6	1134	14.2	1190	15.9	1243
13,000								8.8	982	10.4	1042	12.0	1100	13.6	1155	15.3	1209	17.1	1260
14,000								9.7	1010	11.4	1069	13.1	1125	14.8	1178	16.5	1230	18.4	1280
15,000					9.0	979	10.7	1040	12.4	1097	14.2	1151	16.0	1203	17.8	1254	19.7	1302	
16,000					10.0	1011	11.7	1071	13.5	1126	15.4	1179	17.3	1230	19.2	1279	21.2	1326	
17,000			9.4	982	11.0	1044	12.8	1102	14.7	1156	16.7	1208	18.6	1257	20.7	1305	22.7	1351	
18,000	8.7	952	10.5	1017	12.2	1078	14.1	1135	16.0	1188	18.0	1238	20.1	1286	22.2	1333	24.3	1378	
19,000	9.7	990	11.7	1053	13.6	1112	15.4	1168	17.4	1219	19.5	1269	21.6	1316	23.8	1362	26.0	1406	
20,000	10.9	1028	13.0	1090	15.0	1147	16.9	1201	18.9	1252	21.1	1300	23.3	1347	25.5	1391	27.8	1434	
21,000	12.2	1067	14.4	1126	16.5	1182	18.5	1235	20.6	1285	22.8	1333	25.0	1378	27.4	1422	29.8	1464	
22,000	13.5	1106	15.8	1164	18.1	1218	20.3	1270	22.4	1319	24.6	1365	26.9	1410	29.3	1453	31.8	1494	
23,000	15.0	1145	17.4	1202	19.8	1255	22.1	1305	24.4	1353	26.6	1399	28.9	1443	31.4	1485	33.9	1526	
24,000	16.6	1185	19.1	1240	21.6	1292	24.1	1341	26.4	1388	28.8	1433	31.1	1476	33.6	1517	36.2	1557	

TOTAL STATIC PRESSURE (INCHES OF WATER COLUMN)											
5.5		6.0		6.5		7.0		7.5		8.0	
BHP	RPM	BHP	RPM	BHP	RPM	BHP	RPM	BHP	RPM	BHP	RPM
15.6	1271	17.3	1324	19.1	1375	20.9	1425	22.8	1473	24.7	1521
16.6	1281	18.4	1333	20.2	1383	22.1	1431	24.0	1479	26.0	1525
17.7	1295	19.5	1345	21.4	1394	23.3	1441	25.3	1487	27.3	1532
18.9	1311	20.8	1359	22.7	1407	24.6	1453	26.6	1498	28.7	1542
20.2	1329	22.1	1376	24.1	1423	26.1	1468	28.1	1512	30.3	1555
21.6	1349	23.6	1395	25.6	1440	27.7	1484	29.8	1527	31.9	1570
23.2	1372	25.2	1417	27.3	1460	29.4	1503	31.5	1545	33.7	1586
24.8	1396	26.9	1440	29.0	1482	31.2	1524	33.4	1565	35.7	1605
26.5	1422	28.7	1464	30.9	1506	33.2	1547	35.4	1586	37.8	1625
28.3	1448	30.6	1490	32.9	1531	35.2	1571	37.6	1610	40.0	1648
30.2	1476	32.6	1517	34.9	1557	37.4	1596	39.8	1634	42.3	1671
32.2	1505	34.6	1545	37.1	1584	39.6	1622	42.1	1660	44.7	1696
34.4	1535	36.8	1574	39.4	1612	42.0	1650	44.6	1686	47.2	1722
36.5	1565	39.1	1604	41.8	1641	44.4	1678	47.1	1714	49.9	1749
38.8	1596	41.5	1634	44.2	1671	47.0	1707	49.8	1742	52.6	1777

Return Fan Data

TABLE 16 - RETURN FAN PERFORMANCE

FAN TYPE	2X245
YPAL050-061	X

TABLE 17 - YPAL050-061 : 245 SWSI AIRFOIL FAN

TOTAL STATIC PRESSURE (INCHES OF WATER COLUMN)										
CFM STD. AIR	1.0		1.5		2.0		2.5		3.0	
	BHP	RPM	BHP	RPM	BHP	RPM	BHP	RPM	BHP	RPM
14,000	4.9	1104	6.5	1202	8.2	1290	9.9	1371	11.7	1451
16,000	6.2	1207	8.0	1296	9.9	1380	11.8	1457	13.7	1530
18,000	7.8	1314	9.7	1395	11.8	1474	14.0	1548	16.1	1618
20,000	9.7	1425	11.8	1499	14.0	1572	16.4	1642	18.8	1709
22,000	12.1	1538	14.2	1607	16.6	1674	19.1	1739	21.7	1803
24,000	14.8	1655	17.1	1717	19.5	1780	22.2	1841	24.9	1900

Exhaust Fan Data

EXHAUST FAN MOTOR SIZING INSTRUCTIONS

In order to determine the proper exhaust fan motor size, add the return duct static pressure to the appropriate damper pressure drop value in Table 14 to get the total static pressure applied to the exhaust fan. Based on the exhaust fan airflow and total static pressure, determine the brake horsepower and RPM of the exhaust fan.

TABLE 18 - FORWARD-CURVED FAN

CFM STD. AIR	Total Static Pressure (inches of water column)							
	0.3		0.5		0.8		1.0	
	BHP	RPM	BHP	RPM	BHP	RPM	BHP	RPM
6,000								
8,000								
10,000								
12,000								
14,000							4.5	599
16,000	2.6	398	3.8	500	4.5	559	5.3	6.9
18,000	3.3	421	4.6	515	5.5	574	6.4	625
20,000	4.2	443	5.6	534	6.6	588	7.7	641
22,000	5.3	466	6.9	556	7.9	606	9.0	655
24,000	6.5	490	8.3	579	9.4	627	10.5	672

NOTE: For performance at operating points not included in these tables, consult your local Johnson Controls representative.

Electrical Data

ELECTRICAL SERVICE SIZING

In order to use the electrical service required for the cooling-only Johnson Controls Series 100, use the appropriate calculations listed below from U.L. 1995. Based on the configuration of the unit, the calculations will yield different MCA (minimum circuit ampacity), and MOP (maximum overcurrent protection).

Using the following load definitions and calculations, determine the correct electrical sizing for your unit. All concurrent load conditions must be considered in the calculations, and you must use the highest value for any combination of loads.

Load Definitions:

- **LOAD1** is the current of the largest motor – compressor or fan motor.
- **LOAD2** is the sum of the remaining motor currents that may run concurrently with LOAD1.
- **LOAD3** is the current of the electric heaters – zero for cooling-only units.
NOTE: If electric heater is 40kW, LOAD3 shall be 1.25 the heater full load amps.
- **LOAD4** is the sum of any remaining currents greater than or equal to 1.0 amp.

Use the following calculations to determine MCA and MOP for units supplied with a single-point power connection:

$$\text{MCA} = (1.25 \times \text{LOAD1}) + \text{LOAD2} + \text{LOAD3} + \text{LOAD4}$$

$$\text{MOP} = (2.25 \times \text{LOAD1}) + \text{LOAD2} + \text{LOAD3} + \text{LOAD4}$$

If the MOP does not equal a standard current rating of an overcurrent protective device, then the marked maximum rating is to be the next lower standard rating. However, if the device selected for MOP is less than the MCA, then select the lowest standard maximum fuse size greater than or equal to the MCA.

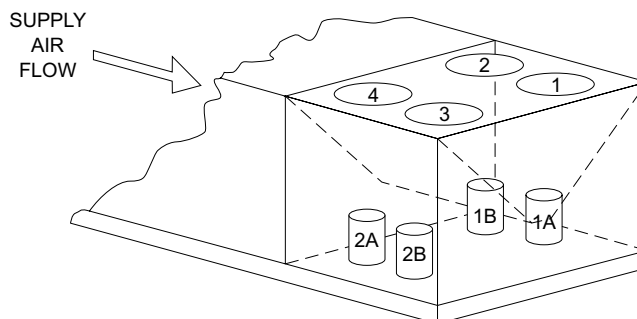

FIGURE 6 - COMPRESSOR & CONDENSER FAN I.D.

Electrical Data (Cont'd)

TABLE 19 - COMPRESSOR ELECTRICAL DATA

MODEL	COMPRESSOR	MODEL	NOMINAL VOLTAGE					
			208-230/3/60		460/3/60		575/3/60	
			RLA*	LRA	RLA*	LRA	RLA*	LRA
050	1A	ZP120	33.3	239	17.9	125	12.8	80
	1B	ZP137	48.1	245	18.6	125	14.7	100
	2A	ZP120	33.3	239	17.9	125	12.8	80
	2B	ZP137	48.1	245	18.6	125	14.7	100
051	1A	ZP137	48.1	245	18.6	125	14.7	100
	1B	ZP137	48.1	245	18.6	125	14.7	100
	2A	ZP137	48.1	245	18.6	125	14.7	100
	2B	ZP137	48.1	245	18.6	125	14.7	100
060	1A	ZP137	48.1	245	18.6	125	14.7	100
	1B	ZP182	55.8	340	26.9	172	23.7	132
	2A	ZP137	48.1	245	18.6	125	14.7	100
	2B	ZP182	55.8	340	26.9	172	23.7	132
061	1A	ZP137	48.1	245	18.6	125	14.7	100
	1B	ZP182	55.8	340	25.0	172	23.7	132
	2A	ZP154	51.3	300	22.4	150	19.8	109
	2B	ZP182	55.8	340	25.0	172	23.7	132

TABLE 20 - POWER SUPPLY VOLTAGE LIMITS

POWER SUPPLY	MINIMUM VOLTAGE	MAXIMUM VOLTAGE
208V/3Ph/60Hz	180	228
230V/3Ph/60Hz	207	253
460V/3Ph/60Hz	414	506
575V/3Ph/60Hz	518	632

TABLE 21 - SUPPLY AND EXHAUST FAN MOTOR DATA - ODP

MOTOR HP	PREMIUM EFFICIENCY - ODP			
	NOMINAL VOLTAGE			
	208/3/60	230/3/60	460/3/60	575/3/60
	FLA	FLA	FLA	FLA
5	14	12.7	6.33	5.06
7.5	20.5	18.5	9.25	7.4
10	27.4	24.8	12.4	9.92
15	41.1	37.2	18.6	14.9
20	55.3	50	25	20
25	66.1	59.8	29.9	23.9
30	78.3	70.8	35.4	28.3
40	107	96.4	48.2	38.6

TABLE 22 - SUPPLY AND EXHAUST FAN MOTOR DATA - TEFC

MOTOR HP	PREMIUM EFFICIENCY - TEFC			
	NOMINAL VOLTAGE			
	208/3/60	230/3/60	460/3/60	575/3/60
	FLA	FLA	FLA	FLA
5	14.4	13	6.49	5.19
7.5	20.1	18.1	9.07	7.26
10	27	24.4	12.2	9.76
15	40.3	36.4	18.2	14.6
20	54.6	49.4	24.7	19.8
25	65.2	59	29.5	23.6
30	77.6	70.2	35.1	28.1
40	107	96.4	48.2	38.6

TABLE 23 - CONDENSER FAN MOTOR RLA

RLA EACH MOTOR		208V/3PH/60HZ	230V/3PH/60HZ	460V/3PH/60HZ	575V/3PH/60HZ
		7.3	6.2	3.1	2.5
UNIT SIZE	QUANTITY OF FANS	208V/3PH/60HZ	230V/3PH/60HZ	460V/3PH/60HZ	575V/3PH/60HZ
50-65 Tons	4	29.2	24.8	12.4	10.0

TABLE 24 - MISCELLANEOUS DATA

DESCRIPTION	NOMINAL VOLTAGE		
	208V/230V	460V	575V
	AMPS	AMPS	AMPS
Control Transformer 0.5 KVA	3.6	1.6	1.3
Convenience Outlet	9.6	4.4	3.5
Gas Heat	9.6	4.4	3.5

TABLE 25 - ELECTRIC HEAT AMP DRAW

KW	208V/3PH/60HZ	240V/3PH/60HZ	480V/3PH/60HZ
	AMPS	AMPS	AMPS
40	111.1	96.3	48.2
80	222.3	192.7	96.3
108	300.1	260.1	130.1
150			180.6

Controls

CONTROL SEQUENCES (VAV) FOR IPU CONTROLLER

GENERAL

The control system for the JOHNSON CONTROLS package unit is fully self-contained and based around a single package unit controller. To aid in unit setup, maintenance, and operation, the single package unit controller is equipped with a user interface that is based around a 4 line x 20 character backlit LCD display. The LCD displays plain language text in a menu-driven format to facilitate use.

Based on the unit type (Single Zone VAV), the Johnson Controls Series 100 Single Package units can be operated by a space temperature sensor or stand alone. A field wiring terminal block is provided to facilitate unit setup and installation.

In lieu of the hard-wired control options, the single package unit controller can be connected to and operated by a Building Automation System (BAS).

The IPU Controller uses the latest technology and provides complete control for the unit along with standard BACnet™ MS/TP and Modbus RTU communications. The IPU also has an SD card slot that can be used to capture historic data on unit operation.

If required, the unit can be equipped with an optional field installed gateway which allows N2 or Echelon® communications. The E-Link gateway device is field installed and purchased through the Advanced Order Management System (AOMS).

YK-ELNKE01-0 – E-Link for Echelon®

YK-ELNKE00-0 – E-Link for N2

UNOCCUPIED / OCCUPIED SWITCHING

Depending on application, the unit can be indexed between unoccupied and occupied modes of operation by one of three methods, hard-wired input, internal time clock, or BAS. A contact-closure input is provided for hard-wiring to an external indexing device such as a central time clock, thermostat with built in scheduling, or a manual switch. The unit controller is also equipped with a built in 7-day time clock which can be used, in lieu of the contact closure input, to switch the unit between Unoccupied and Occupied modes of operation.

The internal time clock is fully configurable via the user interface and includes Holiday scheduling. In addition to the hard-wired input or the internal time clock, the unit can also be indexed between unoccupied and occupied modes of operation via a BAS command.

GAS HEATING OPERATION

Units supplied with gas heat can be equipped one, two, or three independently operated burner modules. Each module is fully self-contained furnace with all necessary ignition controls, safeties, and gas valves. The IPU single package unit controller determines how the furnaces are started and stopped and prevents furnace operation if the Supply Fan airflow is not sufficient or if the Supply Air Temperature is excessively high. If a furnace module receives a signal to start from the IPU controller, the ignition control engages the furnace inducer (draft) fan for a 30-second pre-purge cycle. If a furnace module receives a signal to stop from the IPU controller, the ignition control will stop the furnace and allows the inducer fan to operate for a 30-second post-purge. Each furnace contains a direct

Controls (Cont'd)

spark ignition system and included safeties for flame and inducer fan verification, high temperature and flame roll-out.

MODULATING HOT GAS REHEAT CONTROL

The optional Hot Gas Reheat (HGRH) systems consists of a reheat coil mounted downstream of the unit DX evaporator coil, which is controlled by the single package unit controller. The single package unit controller modulates a 3-way valve to control the amount of discharge gas to the HGRH coil, adding sensible heat to the supply air being delivered to the space. This allows the DX evaporator coil to operate at a lower temperature, removing excess moisture without overcooling the space. When the HGRH control is enabled, the compressors will be staged ON/OFF as needed to achieve and maintain the Active Evaporator Air Temperature (Active EAT) setpoint (SP). The Active EAT SP will be whichever of the following is lower: Active Supply Air Temperature (ASAT) setpoint minus 3.0 °F or Active Supply Air Dew Point (SADP) setpoint. The Active SADP setpoint will be determined by the single package unit controller using the return air relative humidity value, and the SADP is calculated using the current supply air temperature and relative humidity values.

HYDRONIC HEAT

If the unit is configured with either of the wet heat options (steam or hot water) the single package unit controls will modulate the hydronic valve to maintain a supply air setpoint. In the event temperatures off the hydronic coil are below 34 degrees the hydronic valve will open 100%. This function is an automatic reset so as the temperature rises above 36 degrees, the unit will automatically begin normal operation.

ELECTRIC HEATING OPERATION

For units equipped with electric heaters, the unit can control up to six stages of electric heat which are staged on based on heating demand calculates by the IPU controller.

MORNING WARM-UP

Morning Warm-Up can be initialized by BAS or by the IPU controller if the Internal Scheduling is used. If the Internal Scheduling is used, the Morning Warm-Up start time is calculated through an adaptive algorithm. When Morning Warm-Up is required, the IPU controller energizes the VAV heat relay, starts the Supply Fan and qualifies the Return Air Temperature for 5 minutes. The internal heat source (Gas, HW/Steam, or Electric) is controlled to maintain the Return Air Temperature to the Return Air Heating Setpoint, Morning Warm-Up ends when occupancy occurs (BAS, Internal Scheduling, or contact closure), or when the Maximum Morning Warm-Up Time has expired.

ECONOMIZER OPERATION

The unit can be equipped with one of three types of optional economizers, dry bulb, single enthalpy, or comparative enthalpy. When the unit controller determines that Outside Air is suitable for economizing, the unit controller will open the outside air damper(s) open to provide economizer cooling. If economizer cooling alone is insufficient for the cooling load, the unit controller shall stage up compressors, one at a time, to meet demand.

The control logic for the three types of economizers is as follows:

Dry Bulb Economizer

The dry bulb economizer is the default economizer control scheme. With the dry bulb economizer, the unit controller monitors the Outside Air temperature only and compares it to a reference temperature setting. Outside Air is deemed suitable for economizing when the Outside Air temperature is determined to be less than the reference temperature setting. This method of economizing is effective, but is prone to some change-over inefficiencies due to the fact that this method is based on sensible temperatures only and does not take Outside Air moisture content into consideration.

Single Enthalpy Economizer

With the optional single enthalpy economizer, the unit controller monitors the Outside Air enthalpy in addition to the Outside Air temperature and compares it to a reference enthalpy setting and a reference temperature setting. Outside Air is deemed suitable for economizing when the Outside Air enthalpy is determined to be less than the reference enthalpy setting and the Outside Air temperature is less than the reference temperature setting. This method of economizing allows the reference temperature setting to be set higher than the DB Economizer and is consequently a more efficient single package unit economizer.

Dual Enthalpy Economizer

With the optional dual enthalpy economizer, the unit controller monitors and compares the Outside Air and Return Air enthalpies in addition to comparing the Outside Air temperature to the reference temperature setting. Outside Air is deemed suitable for economizing when the Outside Air enthalpy is determined to be less than the Return Air enthalpy and the Outside Air temperature is less than the reference temperature setting. This method of economizing is the most accurate and provides the highest degree of energy efficiency for a packaged single package unit economizer.

VENTILATION CONTROL SEQUENCES

Minimum OA Damper Position (VAV Units)

With Variable Air Volume units, there are two Minimum OA Damper Positions, one when the unit is at full speed and the second when the unit is at approximately half speed. These two points allow the control to linearly reset the position of the OA damper in response to fan speed.

When the unit goes into the Occupied mode of operation, the unit controller shall monitor the speed of the supply fan and open the Outside Air damper to a calculated minimum position based on the fan speed. This minimum position shall vary as the speed of the fan changes. The damper shall remain at this calculated position as long as the unit is in the occupied mode, and the economizer is not suitable for cooling.

Air Measurement Stations

When the unit is equipped with an air measurement station, the unit controller shall control the Outside Air damper to a measured flow rate through the Air Measurement Station.

When the unit goes into the Occupied mode of operation, the unit controller shall control the Outside Air damper to maintain the Minimum AirFlow Setpoint through the Air Measurement Station. The unit controller shall control the Outside Air damper to this flow rate as long as the unit is in the Occupied mode, and the economizer is not suitable for cooling.

Controls (Cont'd)

Demand Ventilation

If optional CO2 sensors are connected to the unit, the unit controller can reset the minimum OA damper position(s) or minimum flow rate based on demand.

The unit controller shall monitor the CO2 level within the building. If the CO2 level rises above the CO2 setpoint, the controller will temporarily increase the Minimum OA Damper Position or Minimum OA flow rate to increase ventilation. If the CO2 level drops below the CO2 setpoint, the controller will decrease the Minimum OA Damper Position or Minimum OA flow rate to decrease ventilation. Demand Ventilation shall remain active as long as the unit is in the Occupied mode of operation.

EXHAUST CONTROL SEQUENCES

Barometric

The optional barometric exhaust system consists of a lightweight barometric relief damper installed on the end of the unit in the Return Air section. As more outside air is introduced into the controlled zone due to Economizer and Ventilation control sequences, the pressure inside the building rises. As building static pressure increases to overcome any exhaust duct static pressure, air will be allowed to escape through the barometric relief damper. Because this type of exhaust is not powered, the amount of air exhausted will be limited to the static pressure that will need to be overcome.

Powered Variable Volume Exhaust-Discharge Damper Controlled

This optional variable volume powered exhaust system consists of a fixed speed fan configured with a proportionally controlled discharge damper. The single package unit controller monitors the pressure inside the building and controls the Exhaust Damper and the Exhaust Fan. If the Building Pressure rises, the Exhaust Damper is proportionally controlled open and the Exhaust Fan is controlled ON. If the Building Pressure falls, the Exhaust Damper is proportionally controlled closed and the Exhaust Fan is controlled OFF. The position of the Exhaust Damper in which the Exhaust Fan is controlled ON and OFF as well as the Building Pressure setpoint is user selectable from the single package unit User Interface.

Powered Variable Volume Exhaust-VFD Controlled

This optional variable volume powered exhaust system consist of an Exhaust Fan driven by a Variable Frequency Drive (VFD), which is controlled by the single package unit controller. The single package unit controller monitors the pressure within the building. As the pressure rises, the VFD is controlled to increase Exhaust Fan speed. As the pressure falls, the VFD is controlled to decrease Exhaust Fan speed. The Building Pressure Setpoint is user selectable from the single package unit User Interface. On/Off control is maintained the same as Exhaust-Discharge Damper control stated above.

Return Fan Controlled

This optional variable volume powered return fan system consists of two return fans controlled by one VFD that is controlled by the single package unit control center. The VFD is controlled to maintain a slightly positive pressure over the mixing box section to prevent reverse flow. As the return and/or exhaust air dampers open, the return plenum pressure drops, the fan will speed up to maintain pressure. When the return and/or exhaust air dampers close, the return plenum pressure increases causing the VFD to slow the fan speed down.

LOW AMBIENT/HEAD PRESSURE CONTROL OPERATION

The single package unit controller continuously monitors the outside air temperature to determine if mechanical cooling should be allowed. As a safety, if the Outside Air temperature falls to or below the Low Ambient Lockout temperature, mechanical cooling is prevented from operating. For units with economizers, the Low Ambient Lockout temperature is typically low enough that mechanical cooling will rarely be required. However, for some applications mechanical cooling is required when the Outside Air temperature is lower than the Low Ambient Lockout temperature.

For these applications, the unit must be equipped with optional Low Ambient controls. For optional Low Ambient operation, the single package unit controller monitors the refrigeration system discharge pressure and controls the speed of the condenser fans. If the discharge pressure falls, the speeds of the condenser fans are reduced to maintain acceptable condensing pressures in the refrigeration system. With the optional Low Ambient controls, mechanical cooling is allowed down to Outside Air temperatures of 0°F.

SMOKE PURGE SEQUENCES

General

The controls of the Series 100 are designed as standard with a Ventilation Override sequence to remove, exhaust, or ventilate smoke, fumes, or other air born contaminants from the occupied space. This feature offers three selectable operations, which include Purge, Pressurization, and Evacuation. The sequence is activated via one of three binary inputs. Some typical contact closures are smoke detectors, fire alarms, manual switches, etc.

Note: All cooling and heating modes are disabled during Smoke purge.

Purge

Purge shall be used to displace the air inside the space with fresh outside air. When this sequence is started, the following shall occur:

Start the Supply Fan if not already on. (Note, with VAV and FlexSys units, the fan speed shall be controlled to maintain the active Duct Pressure Setpoint.) Start the Return Fan if not already on. Start the Exhaust Fan if not already ON and set the VFD to 100%. Set the OA damper position to 100%. Set the Exhaust damper to 100%.

Pressurization

Pressurization shall be used to pressurize the building or space in order to force the air inside the space through the walls to adjacent spaces or outside the building envelope. When this sequence is started, the following shall occur:

Start the Supply Fan if not already on. (Note, with VAV and FlexSys units, the fan speed shall be controlled to maintain the active Duct Pressure Setpoint.) Stop the Return Fan if on. Stop the Exhaust fan if on and set Exhaust/Return Fan VFD to 0%. Set the OA damper to 100%. Set the Exhaust damper to 0%.

Evacuation

Evacuation shall be used to evacuate (negatively pressurize) the building or space in order to draw air through the walls from adjacent spaces or outside the building envelope. When this sequence is started, the following shall occur:

Controls (Cont'd)

Stop the Supply Fan if on. Start the Return Fan if not already on. Start the Exhaust fan if not already on and set the Exhaust/Return Fan VFD to 100%. Set the OA damper to 0%. Set the Exhaust damper to 100%

SPECIFIC SEQUENCES

(See IOM for further detail)

Variable Air Volume Mode

Occupied Cooling – In the OCCUPIED COOLING mode the Unit Controller monitors the “RETURN AIR TEMP” and compares it to the “RAT COOLING SETPOINT”. The “RAT COOLING SETPOINT” is entered into the Unit Controller through the SETPOINTS key COOLING subsection of the User Interface. If the “RETURN AIR TEMP” is equal to or greater than the “RAT COOLING SETPOINT” plus 0.50 F the Unit Controller will place the unit in the OCCUPIED COOLING mode. The unit will remain in the OCCUPIED COOLING mode until the “RETURN AIR TEMP” is equal to or less than the “RAT COOLING SETPOINT” minus 0.5°F.

Occupied Heating – In the OCCUPIED HEATING mode the Unit Controller monitors the “RETURN AIR TEMP” and compares it to the “RAT HEATING SETPOINT”. The “RAT HEATING SETPOINT” is entered into the Unit Controller through the SETPOINTS key HEATING subsection of the User Interface. If the “RETURN AIR TEMP” is equal to or LESS than the “RAT HEATING SETPOINT” minus 0.50 F the Unit Controller will place the unit in the OCCUPIED HEATING mode. The unit will remain in the OCCUPIED HEATING mode until the “RETURN AIR TEMP” is equal to or greater than the “RAT HEATING SETPOINT” plus 0.5°F.

Unoccupied Cooling – In the UNOCCUPIED COOLING mode the Unit Controller will monitor the “ZONE TEMP” and compare it to the “UNOCC ZONE COOLING SETPOINT”. The “UNOCC ZONE COOLING SETPOINT” is set through the SETPOINTS key, COOLING subsection of the User Interface. If the “ZONE TEMP” is equal to or greater than the “UNOCC ZONE COOLING SETPOINT” temperature plus 0.50 F. the Unit Controller will place the unit in the UNOCCUPIED COOLING mode. The unit will remain in the UNOCCUPIED COOLING mode until the “ZONE TEMP” is equal to or less than the “UNOCC ZONE COOLING SETPOINT” minus 0.5°F.

Unoccupied Heating – In order for the UNOCCUPIED HEATING to function, the “NIGHT SET BACK” setting must be set to ENABLE. This can be done through the PROGRAM key, HEATING subsection of the User Interface. In the UNOCCUPIED HEATING mode the Unit Controller will monitor the “ZONE TEMP” and compare it to the “UNOCC ZONE HEATING SETPOINT”. The “UNOCC ZONE HEATING SETPOINT” is set through the SETPOINTS key, HEATING subsection of the User Interface. If “ZONE TEMP” is equal to or less than the “UNOCC ZONE HEATING S” minus 0.5 °F, the Unit Controller will place the unit in the UNOCCUPIED HEATING mode. The unit will remain in the UNOCCUPIED HEATING mode until the “ZONE TEMP” is equal to or greater than the “UNOCC ZONE HEATING SETPOINT” plus 0.5 °F.

Zone Temperature Control (Hardwired or Communicated) – The unit compares the analog “WIRED ZONE TEMP” or “COMM ZONE TEMP” input to the “OCC ZONE COOLING,” “OCC ZONE HEATING,” “UNOCC ZONE COOLING,” or “UNOCC ZONE HEATING” setpoints to determine the sub-mode of operation.

This following graphic shows what the UNIT MODE would be, based on the difference between the zone temperature and the zone temperature setpoints. The only difference between Hardwired and Communicated is the method the Unit Controller uses to determine the “ZONE TEMP.” In the Hardwired mode, the input is an analog input to the control. In the Communicated mode, the input is a serial input from a BAS control system.

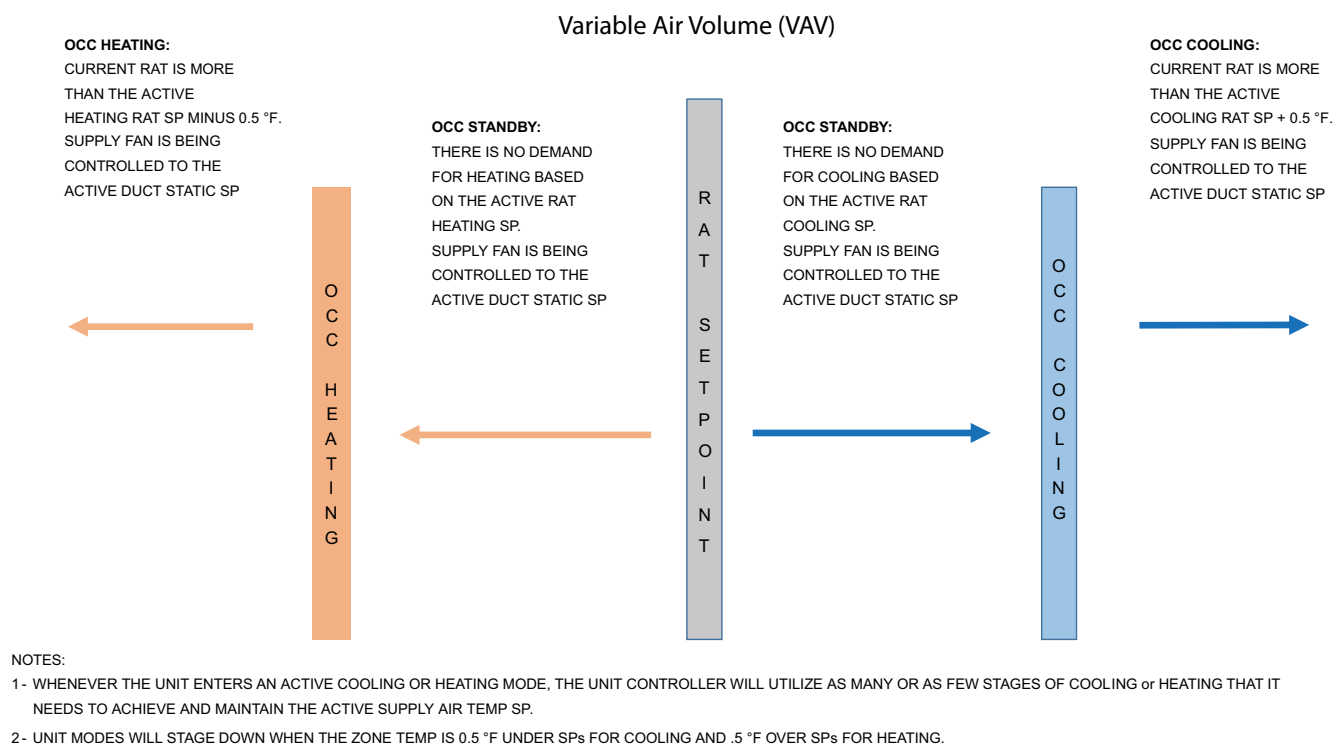

LD20073

FIGURE 7 - OPERATIONAL MODE: VARIABLE AIR VOLUME (VAV)

Single Zone VAV Mode

Units configured for Single Zone VAV operation shall contain a supply fan variable frequency drive. The unit shall switch between cooling mode, heating mode, and standby mode based on zone temperature. In cooling mode, the supply fan speed shall be varied based on zone temperature. If the zone temperature gets warmer, the supply fan speed shall increase. Conversely, if the zone temperature gets cooler, the supply fan speed shall decrease. In heating mode, the supply fan shall run at full speed. When the zone temperature is satisfied, the unit is neither in cooling mode nor heating mode, and the supply fan shall run at minimum speed. Control of cooling and heating stages shall operate in the same manner as a Constant Volume unit with Unit Mode Determination, as described in the following section.

Unit Mode Determination (Hardwired or Communicated) – The unit compares the analog “WIRED ZONE TEMP” or “COMM ZONE TEMP” input to the “OCC ZONE COOLING,” “OCC ZONE HEATING,” “UNOCC ZONE COOLING,” or “UNOCC ZONE HEATING” setpoints to determine the sub-mode of operation. *Figure 7 on page 46* shows what the UNIT MODE would be based on the difference between the zone temperature and the zone temperature setpoints.

The only difference between Hardwired and Communicated is the method the Unit Controller uses to determine the “ZONE TEMP.” In the Hardwired mode the input is an analog input to the control. In the Communicated mode the input is a serial input from a BAS control system.

Controls (Cont'd)

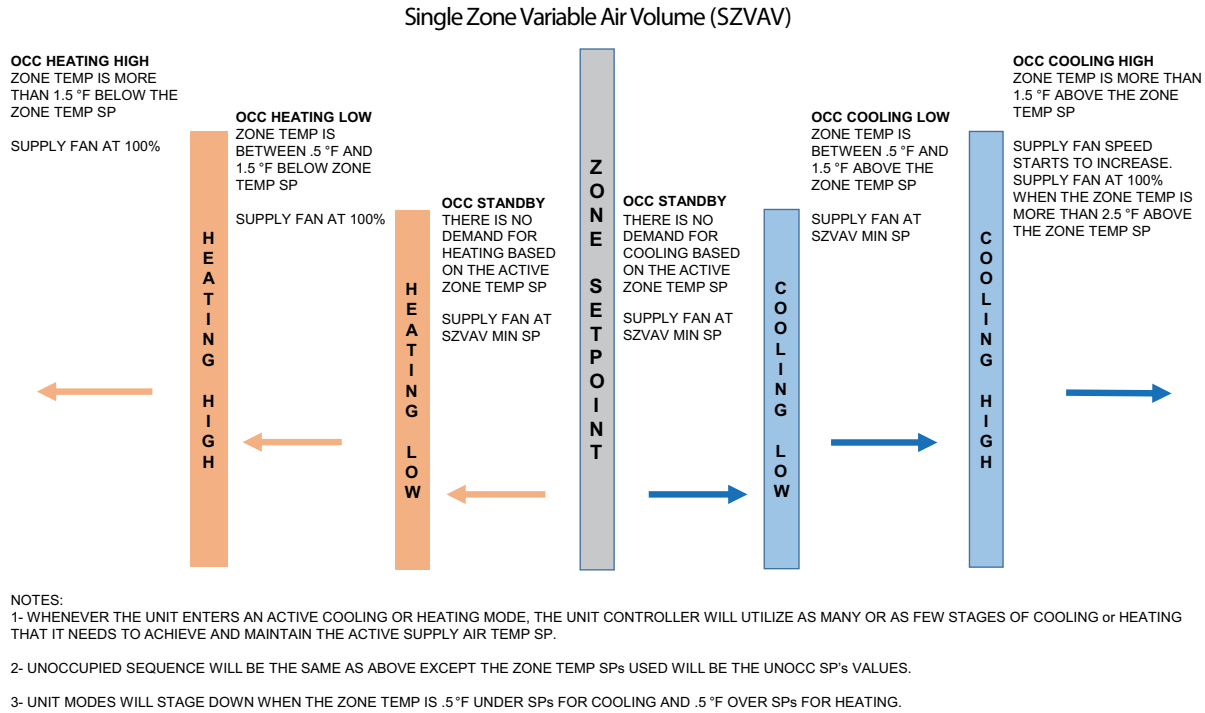

LD19888

FIGURE 8 - OPERATIONAL MODE: SINGLE ZONE VAV

COOLING OPERATION

Zone Sensor Control

If a zone sensor controls the unit, the single package unit controller shall maintain the zone temperature setpoint. This setpoint is user selectable at the single packaged unit User Interface.

When a zone sensor is used for control, the single package unit controller will monitor the temperature within the space and control the unit accordingly. A closed-loop staging algorithm is used to stage compressors up and down as required to maintain the desired zone temperature setpoint. If the unit is equipped with an economizer, Outside Air conditions are continuously monitored by the control to determine if conditions are suitable for economizing. If conditions are suitable for economizing, the single package unit controller will modulate the Outside Air damper in addition to staging compressors up and down to maintain the zone temperature setpoint.

HEATING OPERATION

Zone Sensor Control

If a zone sensor controls the unit, the single package unit controller shall maintain all zone temperature setpoints. These setpoints are user selectable at the single package unit User Interface.

When a zone sensor is used for control, the single package unit controller will monitor the temperature within the space and control the unit accordingly. A closed-loop staging algorithm is used to stage heating steps up and down as required to maintain the desired zone temperature setpoint. If the unit is equipped with an economizer, Outside Air conditions are continuously monitored by the control to determine if conditions are suitable for economizing. If conditions are suitable for economizing, the single package unit controller will modulate the Outside Air damper in addition to staging heating steps up and down to maintain the zone temperature setpoint.

CONTROL SEQUENCES FOR SIMPLICITY ELITE CONTROLLED UNITS

GENERAL

The control system for the Johnson Controls Packaged Unit is fully self-contained and based around a unit controller. To aid in unit setup, unit controller is equipped with a user visual LCD interface that consists of a 2 character above a 4-character display on the front of the Simplicity Elite control board. The two digit indicates the parameter of point number, and the 4-digit displays the current value or setting such as time delay, cooling setpoint temperature, etc. This interface provides verification of the systems operating status, enables field installed options, and aids in troubleshooting system faults.

Four program buttons, located around the LCDs, allow the user to view and/or change 89 default parameter settings, acknowledge 42 alarm codes, and perform a unit run test. Up to five alarm Codes are displayed on the 4-character LCD.

Greater access to programming can be gained through a PDA or Personal Computer (PC). Additionally, up to 64 of the Simplicity family of controllers can be networked together using a 3-conductor shielded cable to communicate with your PC Serial or USB Adapter via the available Johnson Controls recommended FREE net Serial Adapter and free downloaded software.

An LED located on the lower center of the board provides a flash rate of 1 second (heart beat) when no alarms are present. A flash rate of 250 ms indicated that a current alarm is present. The LED lights up constantly if the board has failed and needs replaced, and will not light when the board power is lost.

See the YPAL unit Installation/Operations Manual (IOM) For 100.50-NOM6 (1107) for further Simplicity Elite technical information about the normal Sequence of Operation and user selectable options for our customized applications.

Some common selections include Occupied/Unoccupied/recovery scheduling, equalized runtime for compressors, Morning warm-up, Economizer operation, Comfort, and Demand ventilation.

For the maximum in system flexibility, the Johnson Controls Packaged Unit can be operated by a space temperature sensor or stand-alone (VAV only). Note, a field wiring terminal block is provided to facilitate unit setup and installation.

In lieu of the hard-wired control options, the unit controller can be connected to and operated by a Building Automation System (BAS). The Unit controller is equipped with a Modbus (RTU) communication. Optional BACnet (MSTP) is available with a Simplicity linc translator, which allows communication to a BACNet (MSTP) based BAS.

UNOCCUPIED / OCCUPIED SWITCHING

Depending on application, the unit can be indexed between unoccupied and occupied modes of operation by one of three methods: hard-wired input, internal time clock, or BAS. A contact-closure input is provided for hard-wiring to an external indexing device such as a central time clock, thermostat with built-in scheduling, or a manual switch. The unit controller is also equipped with a built-in 7-day time clock which can be used, in lieu of the contact closure input, to switch the unit between Unoccupied and Occupied modes of operation. The internal time clock is fully configurable via the user interface and includes Holiday scheduling. In addition to the hard-wired input or the internal time clock, the unit can also be indexed between unoccupied and occupied modes of operation via BAS command.

Controls (Cont'd)

GAS HEATING OPERATION

Units supplied with gas heat can be equipped with one, two, or three independently operated burner modules. Each module is a fully self-contained furnace with all necessary ignition controls, safeties, and gas valves. The Unit Controller determines how the furnaces are started and stopped and prevents furnace operation if the Supply Fan airflow is not sufficient or if the Supply Air Temperature is excessively high.

If a furnace module receives a signal to start from the Unit Controller, the ignition control engages the furnace inducer (draft) fan for a 30-second pre-purge cycle. At the end of the 30-second pre-purge, the ignition control will stop the furnace and allows the inducer fan to operate for a 30-second post-purge. Each furnace contains a direct-spark-ignition system and includes safeties for flame and inducer fan verification, high temperature and flame roll-out.

MORNING WARM-UP

Morning Warm-Up can be initialized by BAS or by the Unit Controller if the Intelli-Start is used. If the Intelli-Start is used, the Morning Warm-Up start time is calculated through an adaptive algorithm.

When Morning Warm-Up is required, the Unit Controller energizes the VAV heat relay, starts the Supply Fan and qualifies the Return Air Temperature for 5 minutes.

The internal heat source (Gas, HW/Steam, or Electric) is controlled to maintain the Return Air Temperature to the Return Air Temperature Setpoint. Morning Warm-Up ends when occupancy occurs (BAS, Intelli-Start, or contact closure), or when the Maximum Morning Warm-Up Time has expired.

ECONOMIZER OPERATION

The unit can be equipped with one of three types of optional economizers: dry-bulb, single-enthalpy, or comparative-enthalpy. When the unit controller determines that Outside Air is suitable for economizing, the unit controller will control the outside air damper(s) open to provide economizer cooling. If economizer cooling alone is insufficient for the cooling load, the unit controller shall stage up compressors, one at a time, to meet demand.

The control logic for the three types of economizers is as follows:

Dry-Bulb Economizer

The dry-bulb economizer is the default economizer control scheme. With the dry-bulb economizer, the unit controller monitors the Outside Air temperature only and compares it to a reference temperature setting. Outside Air is deemed suitable for economizing when the Outside Air temperature is determined to be less than the reference temperature setting. This method of economizing is effective, but is prone to some change-over inefficiencies due to the fact that this method is based on sensible temperatures only and does not take Outside Air moisture content into consideration.

Single-Enthalpy Economizer

With the optional, single-enthalpy economizer, the unit controller monitors the Outside Air enthalpy in addition to the Outside Air temperature and compares it to a reference enthalpy setting and a reference temperature setting. Outside Air is deemed suitable for economizing when the Outside Air enthalpy is determined to be less than the reference enthalpy setting and the Outside Air temperature is less than the reference temperature setting. This method of economizing allows the reference temperature setting to be set higher than the dry-bulb Economizer and is a more efficient packaged economizer.

Dual-Enthalpy Economizer

With the optional, dual-enthalpy economizer, the unit controller monitors and compares the Outside Air and Return Air enthalpies, in addition to comparing the Outside Air temperature to the reference temperature setting. Outside Air is deemed suitable for economizing when the Outside Air enthalpy is determined to be less than the Return Air enthalpy and the Outside Air temperature is less than the reference temperature setting. This method of economizing is the most accurate and provides the highest degree of energy efficiency for a packaged economizer.

VENTILATION CONTROL SEQUENCES

Minimum OA Damper Position (CV Units)

When the unit goes into the Occupied mode of operation, the unit controller shall open the Outside Air Damper to a fixed minimum position. The damper shall remain at this position as long as the unit is in the occupied mode, and the economizer is not suitable for cooling.

Minimum OA Damper Position (VAV Units)

With Variable Air Volume units, there are two Minimum OA Damper Positions: one when the unit is at full speed and the second when the unit is at approximately half speed. These two points allow the control to linearly reset the position of the OA damper in response to fan speed.

When the unit goes into the Occupied mode of operation, the unit controller shall monitor the speed of the supply fan and open the Outside Air damper to a calculated minimum position based on the fan speed. This minimum position shall vary as the speed of the fan changes. The damper shall remain at this calculated position as long as the unit is in the occupied mode, and the economizer is not suitable for cooling.

EXHAUST CONTROL SEQUENCES

Barometric

The optional barometric exhaust system consists of a lightweight barometric relief damper installed on the end of the unit in the Return Air section. As more outside air is introduced into the controlled zone due to Economizer and Ventilation control sequences, the pressure inside the building rises. As building static pressure increases to overcome any exhaust duct static pressure, air will be allowed to escape through the barometric relief damper. Because this type of exhaust is not powered, the amount of air exhausted will be limited to the static pressure that will need to be overcome.

Powered, Variable-Volume Exhaust-Discharge Damper Controlled

This optional variable-volume, powered-exhaust system consists of a fixed-speed fan configured with a proportionally controlled discharge damper. The Johnson Controls Series 100 Unit controller monitors the pressure inside the building and controls the Exhaust Damper and the Exhaust Fan. If the Building Pressure rises, the Exhaust Damper is proportionally controlled open and the Exhaust Fan is controlled ON. If the Building Pressure falls, the Exhaust Damper is proportionally controlled closed and the Exhaust Fan is controlled OFF. The position of the Exhaust Damper in which the Exhaust Fan is controlled ON and OFF as well as the Building Pressure setpoint are user-selectable from the Unit User Interface.

Controls (Cont'd)

Powered, Variable-Volume Exhaust-VFD Controlled

This optional variable-volume, powered-exhaust system consists of an Exhaust Fan driven by a Variable Frequency Drive (VFD), which is controlled by the Unit controller. The Unit controller monitors the pressure within the building. As the pressure rises, the VFD is controlled to increase Exhaust Fan speed. As the pressure falls, the VFD is controlled to decrease Exhaust Fan speed. The Building Pressure Setpoint is user-selectable from the Unit User Interface. On/Off control is maintained the same as Exhaust-Discharge Damper control stated above.

POWERED, VARIABLE VOLUME RETURN-VFD CONTROLLED, NO EXHAUST

(Note: Return fan option is not available for CV supply fan Series 100 units.)

A SWSI Plenum fan(s) pulls return air from the building into the return plenum of the unit. The fan(s) operate via a VFD and pressure sensor to maintain a constant pressure within the plenum. This option is designed without exhaust capabilities and the HVAC system must provide alternate means of controlling variable volume return.

POWERED, VARIABLE VOLUME RETURN-VFD CONTROLLED, WITH EXHAUST

(Note: Return fan option is not available for CV supply fan Series 100 units.)

A SWSI Plenum fan(s) pulls return air from the building into the return plenum of the unit. The fan(s) operate via a VFD and pressure sensor to maintain a constant pressure within the plenum. An exhaust hood with modulating damper is provided to maintain building internal pressure via a building static pressure transducer. The building static pressure transducer and tubing are not included and must be field supplied.

LOW-AMBIENT/HEAD-PRESSURE CONTROL OPERATION

The Unit controller continuously monitors the outside air temperature to determine if mechanical cooling should be allowed. As a safety, if the Outside Air temperature falls to or below the Low Ambient Lockout temperature, mechanical cooling is prevented from operating.

For units with economizers, the Low Ambient Lockout temperature is typically low enough that mechanical cooling will rarely be required. However, for some applications, mechanical cooling is required when the Outside Air temperature is lower than the Low Ambient Lockout temperature.

For these applications, the unit must be equipped with optional Low Ambient controls. For optional Low Ambient operation, the Unit controller monitors the refrigeration-system discharge pressure and controls the speed of the first stage condenser fan. If the discharge pressure falls, the speeds of the condenser fan is reduced to maintain acceptable condensing pressures in the refrigeration system. With the optional Low Ambient controls, mechanical cooling is allowed down to Outside Air temperatures of 0 °F.

SMOKE PURGE SEQUENCE

A contact closure input (PURGE) is provided to place the unit in smoke purge mode. When the contact is closed the unit will operate as follows:

- Turn off all heating and cooling operation
- Set the outdoor air damper output to 100%
- Close the return to 0%
- Turn the supply fan on
- On VAV unit set the supply fan output to 100%.
- Turn the power exhaust fan on
- On VFD driven exhaust fans set the exhaust fan output to 100%

Note that 24 volts terminal (R) on the Simplicity control board must be used as the 24 Volt AC source for switch the contact to the Unit Controller Smoke Purge (PURGE) input. Use of any power source external to the controller will result in damage to the Unit Controller.

VAV SPECIFIC SEQUENCES

Supply Fan Operation

For VAV units, the supply fan is controlled ON and OFF based on the occupancy state. When the unit goes into the Occupied mode of operation, the Unit controller will monitor the static pressure within the supply-duct system and control the speed of the supply fan to maintain a specified Duct Static Pressure setpoint. A Variable Frequency Drive (VFD) is used on all VAV units to vary the speed of the supply fan. Note, the use of a VFD in lieu of inlet guide vanes provides for higher energy efficiency for the unit by eliminating the losses (air-pressure drop) typical of inlet guide vane systems.

Special Design Options

TABLE 26 - LISTING OF AVAILABLE SPECIAL DESIGN OPTIONS, YPAL 050-061

OPTIONS	FACTORY DESIGN	ENHANCE DESIGN
Hot gas reheat		X
Energy recovery wheel/plate		X
Fan array		X
Evaporative pre-cooling condenser (adiabatic cooling)		X
UV lamp		X
Smoke detector	X	
Quiet condenser fan		X
4-inch filter rack		X
HEPA filters (MERV 17)	X	

General Arrangement Drawings

BOTTOM SUPPLY / BOTTOM RETURN

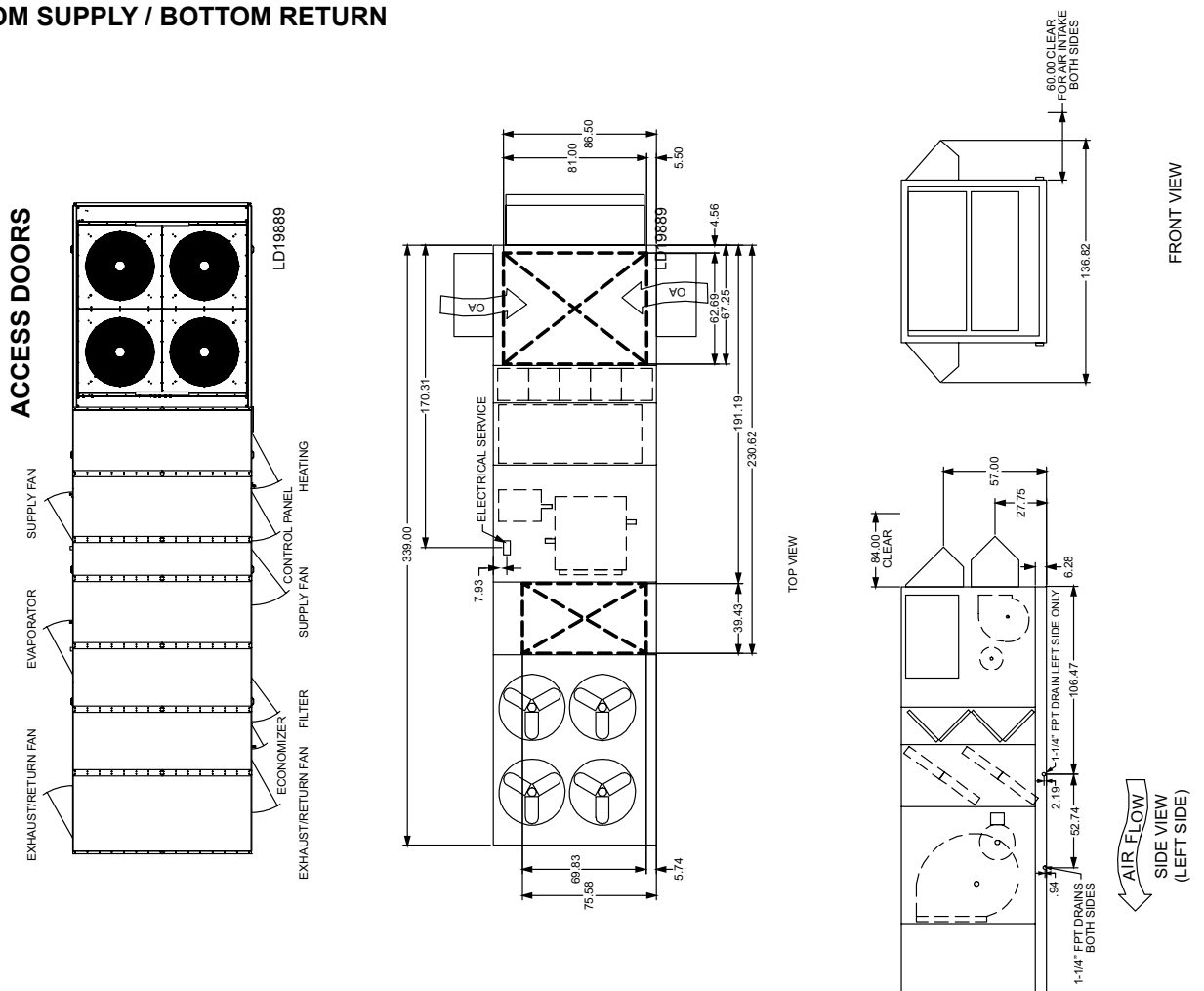

SUPPLY-RETURN-AIR DUCT CONNECTIONS CONFIGURATIONS

UNIT CONFIGURATION		SUPPLY AIR			RETURN AIR		
		BOTTOM	LEFT	RIGHT	BOTTOM	LEFT	FRONT
50-65 TONS	Cooling only	⊙	⊙	⊙	⊙	⊙ ²	⊙ ³
	Cool/gas heat 375-750 MBH	⊙	⊙	N/A	⊙	⊙ ²	⊙ ³
	Cool/gas heat 1,125 MBH	⊙	N/A	N/A	⊙	⊙ ²	⊙ ³
	Cool/electric heat	⊙	N/A	N/A	⊙	⊙ ²	⊙ ³
	Cool/hydrionic heat	⊙	⊙ ¹	⊙ ¹	⊙	⊙ ²	⊙ ³

1. Only with Ext Cab
2. Return LEFT is N/A if power return fan was selected
3. Return REAR is N/A if there is a return fan or any exhaust option

NOTES:

1. 10' Clearance minimum over the top of the condensing unit.
2. Only one adjacent wall can exceed unit height.
3. 12' Clearance required to adjacent units
4. 8' Service access recommended on one side.
5. Outside air hoods are folded for shipment.

FIGURE 9 - GENERAL ARRANGEMENT DRAWING

General Arrangement Drawings (Cont'd)

SIDE SUPPLY / FRONT RETURN

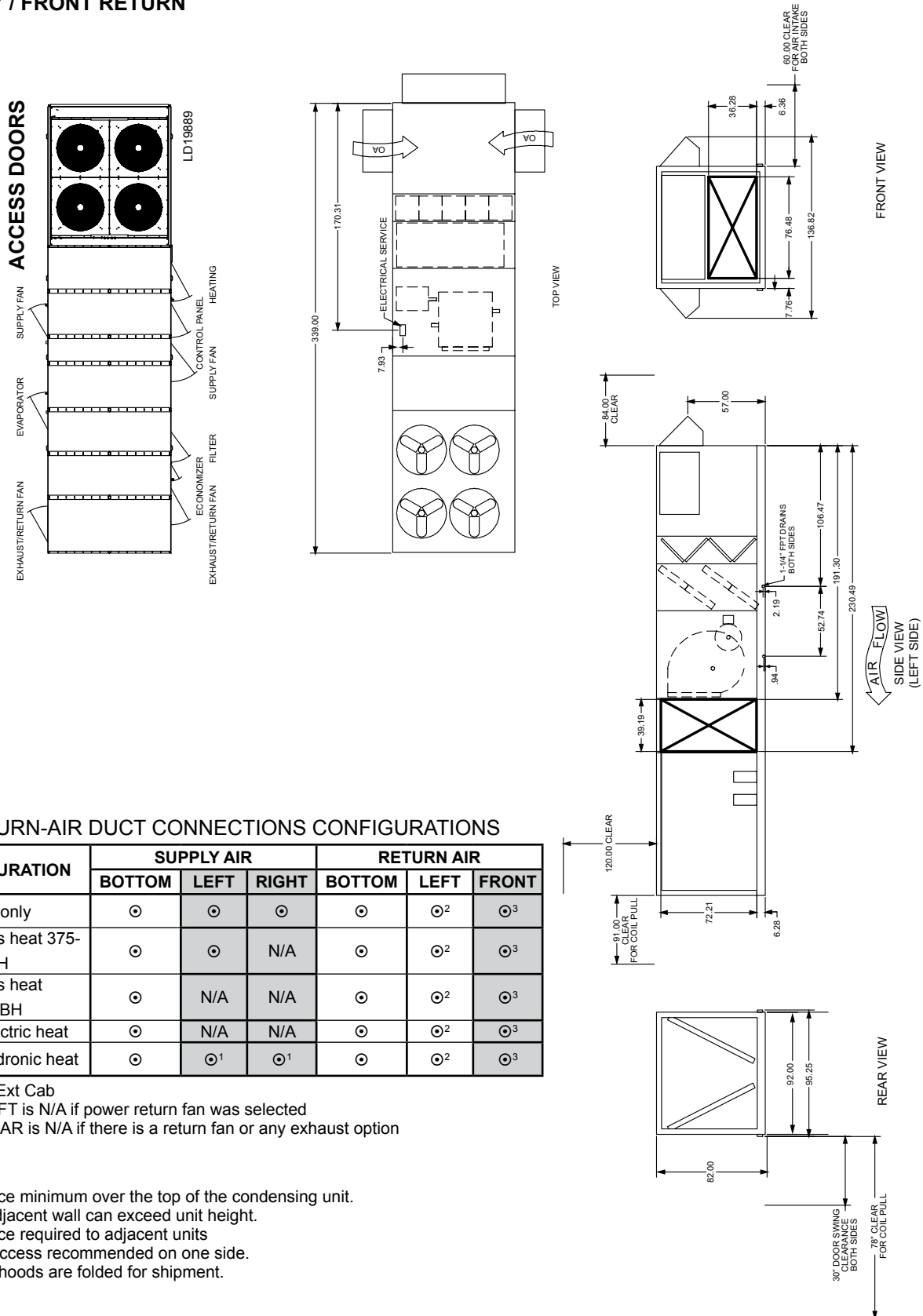

SUPPLY-RETURN-AIR DUCT CONNECTIONS CONFIGURATIONS

UNIT CONFIGURATION		SUPPLY AIR			RETURN AIR		
		BOTTOM	LEFT	RIGHT	BOTTOM	LEFT	FRONT
50-65 TONS	Cooling only	⊙	⊙	⊙	⊙	⊙ ²	⊙ ³
	Cool/gas heat 375-750 MBH	⊙	⊙	N/A	⊙	⊙ ²	⊙ ³
	Cool/gas heat 1,125 MBH	⊙	N/A	N/A	⊙	⊙ ²	⊙ ³
	Cool/electric heat	⊙	N/A	N/A	⊙	⊙ ²	⊙ ³
	Cool/hydrionic heat	⊙	⊙ ¹	⊙ ¹	⊙	⊙ ²	⊙ ³

1. Only with Ext Cab
2. Return LEFT is N/A if power return fan was selected
3. Return REAR is N/A if there is a return fan or any exhaust option

NOTES:

1. 10' Clearance minimum over the top of the condensing unit.
2. Only one adjacent wall can exceed unit height.
3. 12' Clearance required to adjacent units
4. 8' Service access recommended on one side.
5. Outside air hoods are folded for shipment.

FIGURE 10 - GENERAL ARRANGEMENT DRAWING

LD08437

BOTTOM SUPPLY / SIDE RETURN

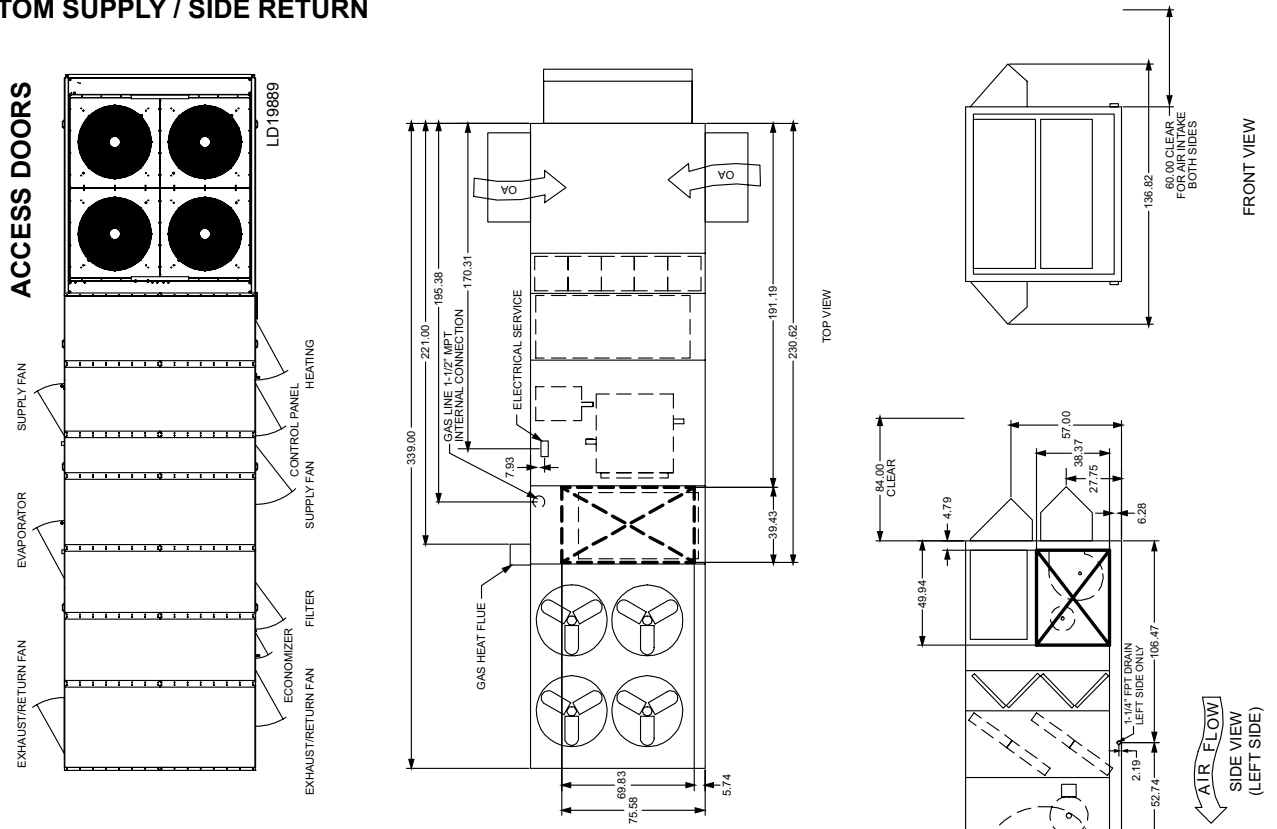

SUPPLY-RETURN-AIR DUCT CONNECTIONS CONFIGURATIONS

UNIT CONFIGURATION	SUPPLY AIR			RETURN AIR		
	BOTTOM	LEFT	RIGHT	BOTTOM	LEFT	FRONT
50-65 TONS	Cooling only	⊙	⊙	⊙	⊙ ²	⊙ ³
	Cool/gas heat 375-750 MBH	⊙	⊙	N/A	⊙	⊙ ²
	Cool/gas heat 1,125 MBH	⊙	N/A	N/A	⊙	⊙ ²
	Cool/electric heat	⊙	N/A	N/A	⊙	⊙ ²
	Cool/hydrionic heat	⊙	⊙ ¹	⊙ ¹	⊙	⊙ ²

1. Only with Ext Cab
2. Return LEFT is N/A if power return fan was selected
3. Return REAR is N/A if there is a return fan or any exhaust option

NOTES:

1. 10' Clearance minimum over the top of the condensing unit.
2. Only one adjacent wall can exceed unit height.
3. 12' Clearance required to adjacent units
4. 8' Service access recommended on one side.
5. Outside air hoods are folded for shipment.

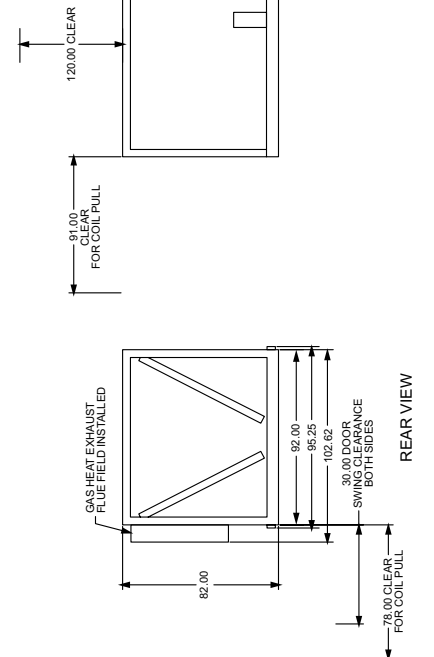
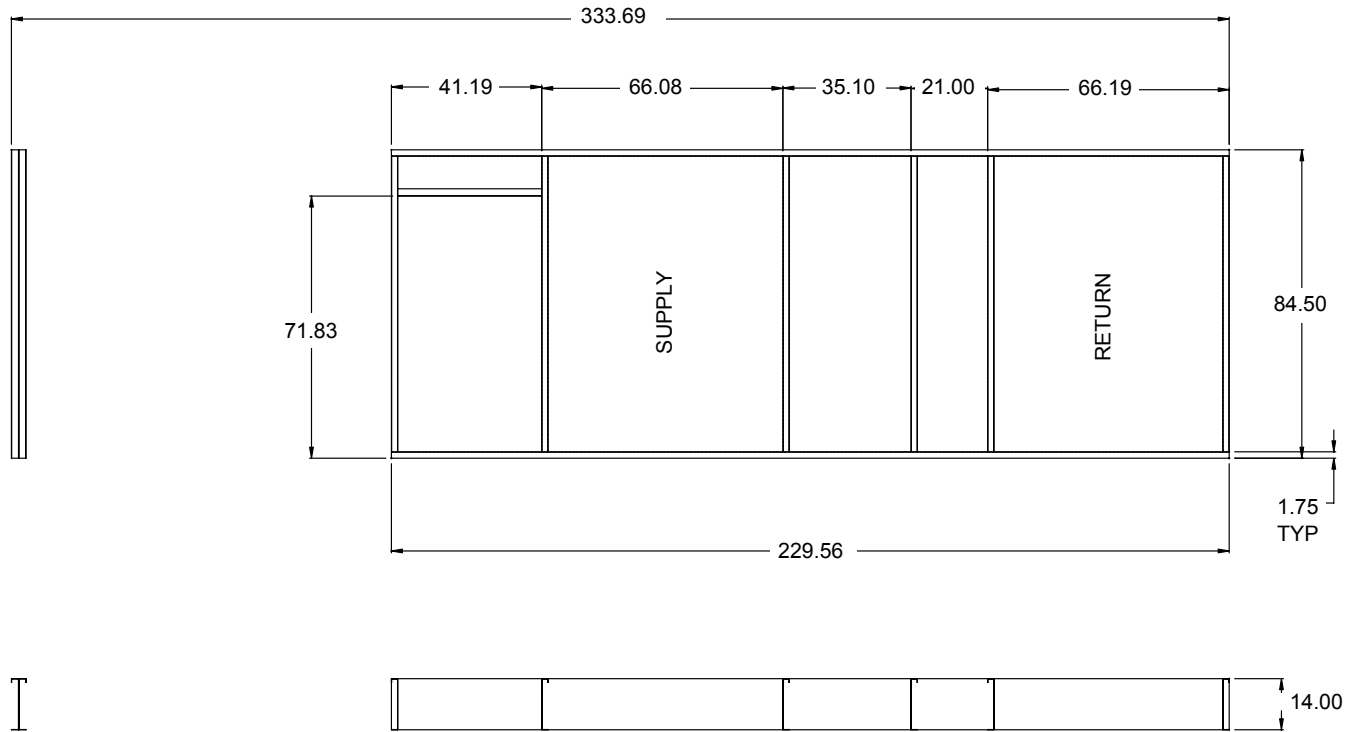
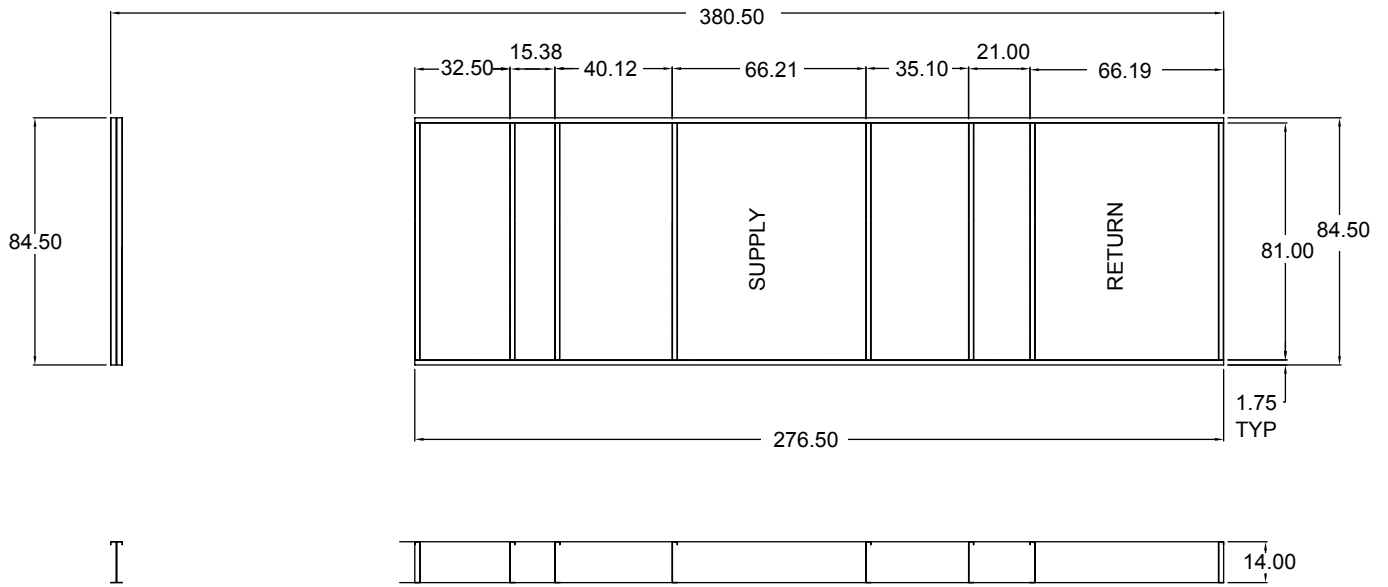

FIGURE 11 - GENERAL ARRANGEMENT DRAWING



STANDARD CABINET

LD08297



EXTENDED CABINET

LD14765

NOTES:

1. Unit must be installed square and level.
2. Curb configuration for "bottom" return and "bottom" supply.
3. These drawings are not intended as construction documents for the field fabricated roof curbs. Johnson Controls will not be responsible for the unit fit up, leak integrity, or sound level for installation using field fabricated roof curbs.
4. The YPAL unit does not have a base pan under the condensing section of the unit. Field fabricated roof curbs must have a cap on the top of the condensing section of the curb to prevent moisture from entering the space. The cap design must be sloped away from the supply duct opening to the end of the unit for the drainage of the moisture off of the top of the cap.

FIGURE 13 - CURB LAYOUT DRAWING / 050-061 MODELS, STANDARD AND EXTENDED CABINET

Unit Weights

TABLE 27 - UNIT WEIGHTS

MODEL	050	051	060	061
BASIC UNIT WEIGHT - STD CABINET	8650	8650	8941	8960
BASIC UNIT WEIGHT - EXT CABINET	9493	9493	9784	9803
ECONOMIZERS				
25% Outside Air Fixed Position Manual Damper	527	527	527	527
25% Outside Air 2 Position Actuated Damper	527	527	527	527
Full Modulation with Minimum Position	527	527	527	527
EXHAUST FAN				
Fan, 15 HP Motor, Modulating Damper and Hood	735	735	735	735
Fan, 15 HP Motor, VFD, Barometric Damper and Hood	769	769	769	769
RETURN FAN				
Fan, 15 HP, Motor	1125	1125	1125	1125
GAS HEAT				
375 MBH	162	162	162	162
750 MBH	324	324	324	324
1125 MBH (Bottom Discharge)	486	486	486	486
ELECTRIC HEAT				
40kW (Max)	410	410	410	410
80kW (Max)	430	430	430	430
108kW (Max)	450	450	450	450
150kW (Max)	470	470	470	470
Hot Water Coil	281	281	281	281
Steam Coil	202	202	202	202
OPTIONS				
Open Perimeter Curb - Std. Cabinet	512	512	512	512
Open Perimeter Curb - Ext. Cabinet	608	608	608	608
Condenser Coil Wire Guard	64	64	64	64
Hot Gas Reheat Coil	400	400	400	400
Copper Evaporator Coils (additional)	440	440	620	620
Copper Condenser Coils (additional)	520	520	760	760
12" Rigid Filters (additional)	319	319	319	319

NOTE: Weights shown represent approximate shipping weights and have a \pm 10% accuracy

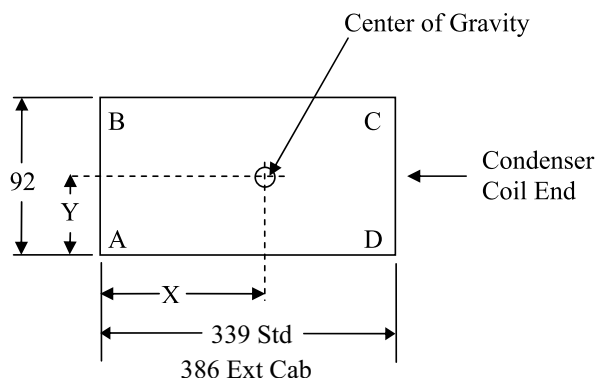

TABLE 28 - UNIT CENTER OF GRAVITY - (STANDARD CABINET)

MODEL	050		051	
	X	Y	X	Y
Basic Unit	189	44	189	44
Basic Unit w/ Econ.	181	44	181	44
Basic Unit w/ Econ. & Heating (Hot Water Heat)	182	44	182	44
Basic Unit w/ Econ. & Heating (Hot Water Heat) & Power Exhaust (10 HP Motor, Modulating Damper, No VFD)	171	44	171	44
MODEL	060		061	
	X	Y	X	Y
Basic Unit	189	44	189	44
Basic Unit w/ Econ.	181	44	182	44
Basic Unit w/ Econ. & Heating (Hot Water Heat)	182	44	182	44
Basic Unit w/ Econ. & Heating & Power Exhaust (10 HP Motor, Modulating Damper, No VFD)	172	44	172	44

TABLE 29 - UNIT CORNER WEIGHTS

MODEL	050				051			
	A	B	C	D	A	B	C	D
Basic Unit	2011	1816	2288	2534	2011	1816	2288	2534
Basic Unit w/ Econ.	2236	2031	2318	2553	2236	2031	2318	2553
Basic Unit w/ Econ. & Heating	2281	2092	2413	2632	2281	2092	2413	2632
Basic Unit w/ Econ. & Heating & Power Exhaust	2607	2390	2431	2652	2607	2390	2431	2652
MODEL	060				061			
	A	B	C	D	A	B	C	D
Basic Unit	2077	1868	2366	2630	2076	1873	2376	2634
Basic Unit w/ Econ.	2302	2082	2395	2649	2301	2087	2406	2653
Basic Unit w/ Econ. & Heating	2347	2143	2491	2728	2346	2148	2502	2732
Basic Unit w/ Econ. & Heating & Power Exhaust	2673	2441	2509	2748	2672	2446	2519	2752

Unit Weights (Cont'd)

TABLE 30 - UNIT CENTER OF GRAVITY - (EXTENDED CABINET)

MODEL	50		51		60		61	
COORDINATE	X	Y	X	Y	X	Y	X	Y
Basic Unit	212	44	212	44	212	44	213	44
Basic Unit w/ Econ.	203	44	203	44	204	44	204	44
Basic Unit w/ Econ. & Heating (Hot Water Heat)	204	44	204	44	204	44	205	44
Basic Unit w/ Econ. & Heating (Hot Water Heat) and Power Exhaust (10HP Motor, Modulating Damper, No VFD)	192	44	192	44	193	44	194	44

TABLE 31 - UNIT CORNER WEIGHTS - (EXTENDED CABINET)

MODEL	50				51			
COORDINATE	A	B	C	D	A	B	C	D
Basic Unit	2241	2041	2483	2727	2241	2041	2483	2727
Basic Unit w/ Econ.	2469	2258	2510	2744	2469	2258	2510	2744
Basic Unit w/ Econ. & Heating (Hot Water Heat)	2522	2327	2598	2815	2522	2327	2598	2815
Basic Unit w/ Econ. & Heating (Hot Water Heat) and Power Exhaust (10HP Motor, Modulating Damper, No VFD)	2850	2628	2612	2833	2850	2628	2612	2833
MODEL	60				61			
COORDINATE	A	B	C	D	A	B	C	D
Basic Unit	2307	2092	2561	2824	2306	2097	2572	2828
Basic Unit w/ Econ.	2535	2310	2587	2839	2534	2315	2598	2844
Basic Unit w/ Econ. & Heating (Hot Water Heat)	2588	2378	2675	2911	2587	2383	2686	2915
Basic Unit w/ Econ. & Heating (Hot Water Heat) and Power Exhaust (10HP Motor, Modulating Damper, No VFD)	2916	2679	2690	2929	2915	2684	2701	2933

Hot Water/Steam Coil Connection Locations

HOT WATER COIL

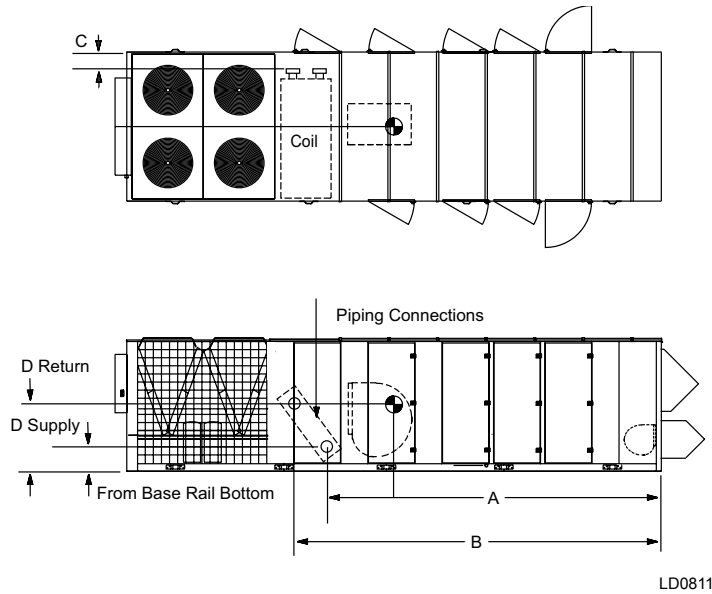

STEAM COIL

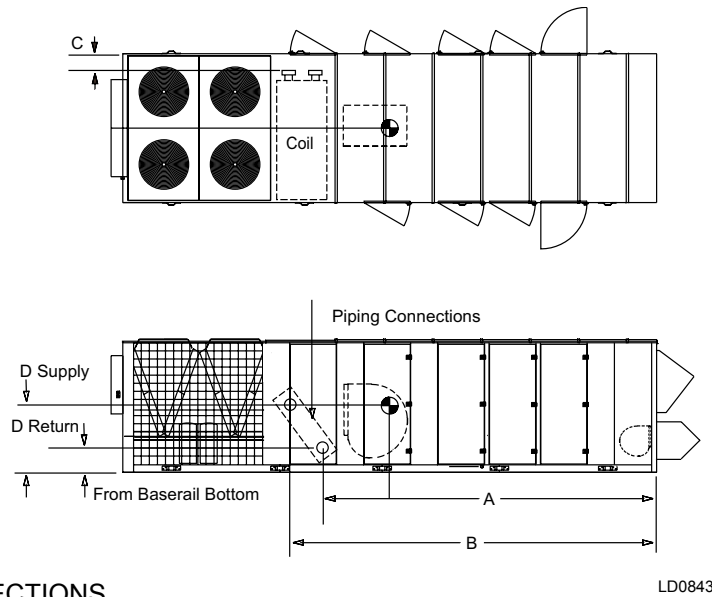

FIGURE 14 - COIL CONNECTIONS

TABLE 32 - FITTING LOCATION DIMENSIONS

UNIT SIZE	A	B	C	D _{SUPPLY}	D _{RETURN}	CONNECTION SIZE (INCHES)	
	NOTE 1	NOTE 2	NOTE 3	NOTE 4	NOTE 4	SUPPLY	RETURN
HOT WATER							
50-65	197.08	225.33	9.00	19.34	46.72	2" FPS	2" FPS
STEAM							
50-65	195.33	211.33	9.31	32.84	19.34	2" MPT	1.5" MPT

NOTES:

1. Location of return (steam) or supply (HW) line connection, horizontal from economizer corner post, in direction of airflow
2. Location of supply (steam) or return (HW) line connection, horizontal from economizer corner post, in direction of airflow
3. Location of both supply and return lines, horizontal from outside casing of unit, across direction of airflow
4. Location of supply and return lines, vertical from bottom edge of base rail

MPT = Male Pipe Thread FPS = Female Pipe Sweat FPT = Female Pipe Thread
 Steam and Hot Water connections w/o controls are fittings connections facing side of the unit, at locations indicated.

Power/Control Entry Drawing – 50–61 Models

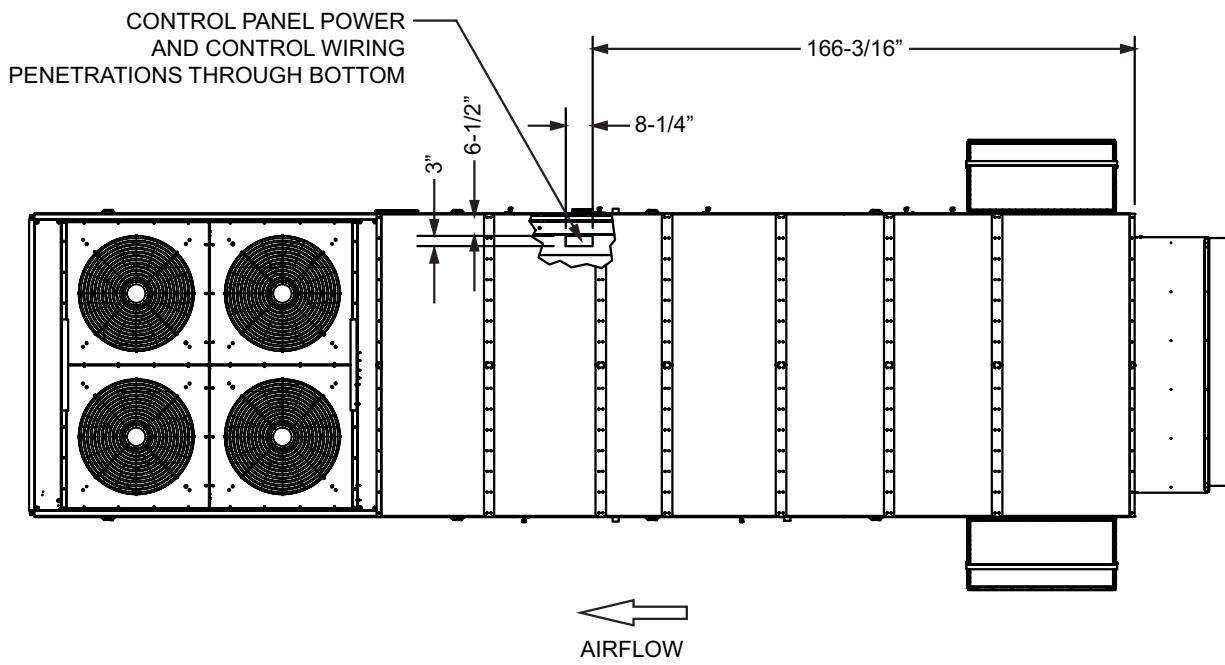

LD19504

FIGURE 15 - POWER/CONTROL WIRING LOCATION

Guide Specifications

GENERAL

Scope

The requirements of the General Conditions, Supplementary Conditions, Division 1 and drawings apply to all work herein.

Provide microprocessor-controlled, air-cooled, double-wall-construction, outdoor packaged air conditioning product of the scheduled capacities and performance as shown and indicated on the drawings, including but not limited to:

1. Single-piece package
2. Charge of refrigerant and oil
3. Electrical power and control connections
4. Supply and return duct connections
5. Factory start-up

Quality Assurance

All units are tested, rated or certified, as applicable, in accordance with the following standards, guidelines and codes:

1. All units shall meet the latest ASHRAE 90.1 .2013 minimum energy-efficiency requirements (EER)
2. All units shall be rated in accordance with the ARI Standard 340/360
3. All units shall be tested to ANSI/UL 1995 and CAN/CSA C22.2 No. 236 standards
4. Gas heating units shall be designed in conform to ANSI Z21.47-2006/CS2.3-2006 standards and be carry the ETL listing
5. Units shall be ETL and ETL Canada listed

Manufacturers: The design shown on the drawing is based upon products of the manufacturer scheduled. Alternate equipment manufacturers shall be acceptable if equipment meets the scheduled performance and complies with these specifications. If equipment manufactured by manufacturer other than that scheduled is utilized, then the Mechanical Contractor shall be responsible for coordinating with the General Contractor and all affected Subcontractors to insure proper provisions for installation of the furnished unit. This coordination shall include, but not be limited to, the following:

1. Structural supports for units.
2. Roof curb transition.
3. Piping size and connection/header locations.
4. Electrical power requirements and wire/conduit and overcurrent protection sizes.
5. All costs incurred to modify the building provisions to accept the furnished units.

Guide Specifications (Cont'd)

Warranty: Manufacturer shall warrant all equipment and material of its manufacture against defects in workmanship and material for a period of 12 months from startup or 18 months from date of shipment, whichever occurs first. Stainless steel gas heat exchanger is 10 years.

1. The warranty shall include parts only during this period.
2. The warranty shall not include parts associated with routine maintenance, such as belts, air filters, etc.

Delivery and Handling

Unit shall be delivered to the job site fully assembled, wired, and charged with refrigerant and oil by the manufacturer. Unit shall be stored and handled per Manufacturer's instructions.

All handling and storage procedures shall be per manufacturer's recommendations.

Submittals

Shop Drawings: Shop drawing submittals shall include, but not limited to, the following: drawings indicating components, dimensions, weights, required clearances, and location, type and size of field connections, and power and control wiring connections.

Product Data: Product data shall include dimensions, weights, capacities, ratings, fan performance, motor electrical characteristics, and gauges and finishes of materials.

Documentation:

1. Fan curves with specified operating point clearly plotted shall be provided.
2. Product data of filter media, filter performance data, filter assembly, and filter frames shall be provided.
3. Electrical requirements for power supply wiring; including wiring diagrams for interlock and control wiring shall be supplied. Factory and field-installed wiring shall be clearly indicated.
4. Operation and maintenance documentation shall be supplied in accordance with Section 01830 – Operation and Maintenance, including but not limited to instructions for lubrication, filter replacement, compressor, motor and drive replacement, coil cleaning, filter maintenance, spare parts lists, and wiring diagrams.

Warranties

Equipment shall include the manufacturer's warranty not less than eighteen months from the date of shipment.

Extended parts warranty [optional] shall be included for an additional one [five] years

Extended parts and labor warranty [optional] shall be included for an additional one [five] years

EQUIPMENT

Product Specification

Summary: Completely factory assembled unitized construction packaged air conditioning unit including a factory-mounted and wired unit controller and sensors, single-point power connection 460V [208V/230V/ 575V] three-phase, 60Hz power supply, outdoor air handling section with return and supply openings, discharge plenum, direct-expansion refrigerant condensing section.

Factory Test: The refrigerant circuit shall be pressure-tested, evacuated and fully charged with refrigerant and oil. The completed refrigerant circuit shall undergo a factory helium leak test and undergo an automated operational run test and quality inspection prior to shipment. The unit controller shall be configured and run tested at the factory to minimize field setup time. Gas fired units are run tested. If the unit is not configured and tested, then the manufacturer shall provide field start up and testing to ensure that the controller is functioning properly.

Unit Construction

Base Rail: The unit shall include an integral design base rail with lifting points clearly marked and visible on the base rail, and three 1-1/4" FPT connections for condensate drainage. The unit base shall be designed with a recessed curb mounting location. The recessed curb mounting surface shall provide a continuous surface for field application of curb gasketing to create a weather tight seal between the curb and unit.

Casing: Casing shall be complete post and panel construction with exterior skin. All panels, doors, walls, uprights, floor panels and roofing shall be one-inch thick; 1-1/2 pound density insulation. Units are specifically designed for outdoor installation.

Roof: The unit roof shall be bowed with the peak in the middle of the unit and sloped to both sides of the unit for drainage. A drip lip shall run the length of the unit to prevent water drainage down the side of the unit. Roof and sidewall seams shall be continuously caulked and covered with formed galvanized seam caps. All panel fasteners shall be secured through standing seams to prevent fastener penetrations that are exposed to the air stream.

Paint: Exterior painted surfaces are designed to withstand a minimum of 1,000 salt spray hours when tested in accordance with ASTM B-117.

Markings and Diagrams: All necessary tags and decals to aid in the service and/or indicating caution areas shall be provided. Electrical wiring diagrams shall be attached to the control panel access door.

Documentation: Installation and operation maintenance manuals shall be supplied with each unit.

Access Doors: Double wall access doors shall be provided in the fan, coil, filter and inlet sections of the unit. Doors shall be double-wall construction with a solid liner and a minimum thickness of 1- inch. Doors shall be attached to the unit with piano-type stainless steel hinges. Latches shall be positive-action, creating an airtight seal between the door and unit. Panels and doors shall be completely gasketed with a closed-cell, neoprene gasket. Door tiebacks shall be provided for all doors to secure doors while servicing.

Guide Specifications (Cont'd)

Economizer Type

[SELECT NONE, OR ONE OF THE FOLLOWING]

1. **No Outside-Air:** the unit has no provisions for outside ventilation air.
2. **Modulating Economizer:** This option includes modulating outdoor air and return air dampers that are interlocked (YPAL050-061 mechanical interlock, YPAL070-150 software interlock) and positioned by fully modulating, solid-state damper actuators. Control of the damper is via a standard ambient outdoor air dry bulb sensor, or optional single or comparative enthalpy controls.
3. **Manual Outside-Air Damper:** A manually adjustable outside-air damper capable of admitting 0-25% outside-air shall be provided.
4. **Two-Position, Outside-Air Damper:** A two-position, outside-air damper capable of admitting 0-25% outside-air shall be provided. The minimum position shall be manually adjustable from 0-25%. Control shall be based on the occupied mode of the unit. For occupied mode, the damper shall be open to the minimum position and for unoccupied, it shall be closed.
5. **Modulating Economizer:** The economizer segment shall be designed to use outside air for cooling and ventilation and provide a means of exhausting air from the air-handling unit. The segment shall consist of parallel-acting, low-leak dampers. The return-air, outside-air and exhaust-air dampers shall be sized for 100% of nominal unit airflow. The exhaust-air damper assembly shall have a factory-assembled rain hood. The rain hood shall have a drip-lip the full width of the hood to channel moisture away from the air being drawn into the unit.

Economizer Leakage

[SELECT ONE OF THE FOLLOWING]

1. Damper assemblies are low-leak design. Damper blades are fabricated from a minimum of 16-gauge galvanized steel. Blade edges are covered with vinyl seals
2. Damper assemblies have a maximum leakage rate of 10 CFM/Sq-ft at 1.0 in WC when tested in accordance with AMCA Standard 500, and have a longevity of 60,000 damper opening and closing cycles, complying with the requirements of California Title 24.

[SELECT ONE OF THE FOLLOWING TYPES OF BUILDING PRESSURE CONTROL]

1. **No Building Exhaust/Relief:** The unit has no provisions to exhaust building return air.
2. **Barometric Relief Damper:** Building air exhaust shall be accomplished through barometric relief dampers installed in the return-air plenum. The dampers open relative to the building pressure. The opening pressure shall be adjustable.
3. **On/Off, Fan-Powered Exhaust:** A DWDI forward-curved centrifugal exhaust fan shall be provided to exhaust building return air to relieve building static pressure. The fans shall be constant volume and operate based on either a building static pressure, or outside air-damper position.

4. **Powered Exhaust with Modulating Discharge Damper:** A DWDI forward-curved centrifugal exhaust fan shall be provided to exhaust building return air to relieve building static pressure. The fans shall operate at a constant volume and operate based on building static pressure. Exhaust airflow shall be modulated via a parallel-acting, control damper. The exhaust-air dampers shall be sized for 100% of the exhaust airflow.
5. **Powered Exhaust with Variable-Frequency-Drive:** A twin DWDI forward-curved centrifugal exhaust fan shall be provided to exhaust building return air to relieve building static pressure. Exhaust airflow shall be modulated via a factory-installed and commissioned variable-frequency-drive with the same nameplate horsepower as the supply fan motor.
6. **Power Return Fan:** A SWSI plenum fan shall be provided to draw return air from the building to the rooftop unit. An access door shall be provided on at least one side of the unit for fan/motor access. The return fan shall operate to maintain a constant pressure within the return plenum.
7. **Power Return Fan w/Exhaust:** A SWSI plenum fan shall be provided to draw return air from the building to the rooftop unit. An access door shall be provided on at least one side of the unit for fan/motor access. The return fan shall operate to maintain a constant pressure within the return plenum. A discharge damper shall be provided to modulate building exhaust. The damper shall be controlled via building pressure. The return damper shall be linked with the outside air damper to modulate volumes of return and outside airflows.

[FOR POWERED-EXHAUST OR RETURN FAN OPTIONS ABOVE, USE THE FOLLOWING]

Fan Motor: Fan motors shall be NEMA design ball-bearing types with electrical characteristics and horsepower as specified. [Optional shaft grounding rings on motors increase motor longevity when applied with a VFD.] Motors shall be open drip-proof (ODP) type or total enclosed fan-cooled (TEFC). The motor shall be located within the unit on an adjustable base.

Mountings: Fan and fan motor shall be internally mounted and isolated on a full width isolator support channel using 1-inch [2-inch] springs. The fan discharge shall be connected to the fan cabinet using a flexible connection to insure vibration-free operation.

Bearings and Drives: Fan bearings shall be self-aligning, pillow block or flanged type regreaseable ball bearings and shall be designed for an average life (L50) of at least 200,000 hours. All bearings shall be factory lubricated and equipped with standard hydraulic grease fittings and lube lines extended to the motor side of the fan. Fan drives shall be selected for a 1.5 service factor and antistatic belts shall be furnished. All drives shall be fixed pitch. Fan shafts shall be selected to operate well below the first critical speed and each shaft shall be factory coated after assembly with an anticorrosion coating.

Filter Section

[SELECT A FILTER RACK, FILTER MEDIA, AND SWITCH IF DESIRED]

1. **Angled Filter Rack:** 2-inch throwaway filters shall be provided in an angled filter rack.
2. **Angled Filter Rack:** 2-inch carbon media filters shall be provided in an angled filter rack.

Guide Specifications (Cont'd)

3. **Angled Filter Rack:** 2-inch cleanable filters shall be provided in an angled filter rack.
4. **Angled Filter Rack:** 2-inch pleated MERV 8 or 2-inch carbon MERV 8 filters shall be provided in an angled filter rack.
5. **Flat Filter Rack:** 12-inch MERV 11 with 2-inch MERV 8 pre-filters shall be provided in a flat filter rack.
6. **Flat Filter Rack:** 12-inch MERV 14 with 2-inch MERV 8 pre-filters shall be provided in a flat filter rack.
7. **Dirty Filter Alarm:** A dirty-filter switch shall be provided and wired to the unit control panel. Upon closure of the switch, the controller shall display a dirty-filter fault. The setting of the switch can be changed manually to close at a specified pressure drop across the filters.

Evaporator Section

1. **Cooling Coil:** Evaporator coils shall be direct-expansion type with intertwined circuiting to assure complete coil-face activity during part-load operation. Coil tubes shall be 3/8" OD copper, with internally enhanced tubes. Fins shall be enhanced mechanically expanded to bond with the copper tubes. Coil casing shall be fabricated from heavy-gauge galvanized steel. All coils shall be pressure tested at a minimum of 450 PSIG.
2. **IAQ Stainless Steel Drain Pan:** The main coil drain pan shall be double-sloped with a condensate connection through the base rail of the unit. Clearance between the evaporator coil and the drain pan shall allow for easy access to the drain pan for cleaning, and shall be visible for inspection without the removal of components.
3. **Intermediate Stainless Steel Drain Pan:** Coils with finned height greater than 48" shall have an intermediate drain pan extending the entire finned length of the coil.

The intermediate pans shall have drop tubes to guide condensate to the main drain pan.

Supply Fan Section

1. **Fan:** The fan section shall be equipped with a single double-width, double-inlet (DWDI), forward-curved **[airfoil optional]** centrifugal type wheel for horizontal discharge. An access door shall be provided on both sides of the unit for fan/motor access.
2. **Fan Motor:** Fan motors shall be NEMA design ball-bearing types with electrical characteristics and horsepower as specified. [Optional shaft grounding rings on motors increase motor longevity when applied with a VFD.] Motors shall be ODP type [TEFC optional]. The motor shall be located within the unit on an adjustable base.

Mountings: Fan and fan motor shall be internally mounted and isolated on a full-width, isolator-support channel using 1-inch [2-inch] springs. The fan discharge shall be connected to the fan cabinet using a flexible connection to insure vibration-free operation.

Bearings and Drives: Fan bearings shall be self-aligning, pillow block or flanged type regreaseable ball bearings and shall be designed for an average life (L50) of at least 200,000 hours. All bearings shall be factory lubricated and equipped with standard hydraulic grease fittings and lube lines extended to the motor side of the fan. Fan drives shall be selected for a 1.5 service factor and antistatic belts shall be

furnished. All drives shall be fixed pitch. Fan shafts shall be selected to operate well below the first critical speed and each shaft shall be factory coated after assembly with an anticorrosion coating.

3. **VAV Fan Control:** Series 100 units are available for a traditional overhead Variable Air Volume system. In this configuration, the Supply Fan speed is controlled by a VFD to maintain duct pressure. The duct pressure setpoint can be fixed or it can be reset via a BAS or a 0-5VDC analog input for optimized duct static pressure control. Operating mode (colling, heating, ventilation) changes are controlled by the Return Air Temperature. However, a space temperature sensor or BAS must be used for Night Set Back and Morning Warm Up operation.

Note: For duct pressure control, a Duct Static Pressure Transducer is included. However, 5/16- or 1/4-inch plastic tubing and a static pressure probe must be field supplied/installed approximately 3/4 down the longest supply duct run.

4. **Single Zone VAV:** Series 100 is available for single zone variable air volume (VAV) applications in compliance with ASHRAE 90.1-2010 and 2013. In cooling mode, refrigeration capacity or compressor stages are cycled on or off to maintain supply air temperature. Likewise in heating, additional stages are cycled on or or modulated on to maintain supply air temperature setpoint. The supply fan speed is modulated to maintain zone temperature setpoint. The S100 uses either a BAS signal or a zone temperature sensor to determine zone temperature and deviation from setpoint. Either a BAS signal or a zone temperature sensor is required in the conditioned space.
5. **Optional VFD Manual Bypass:** A two-contactor manual bypass shall be provided to permit replacement of the VFD in the event of a power failure.
6. **Optional VFD Reactor:** A 3% impedance AC line reactor shall be provided for the supply fan VFD. A 3% impedance AC line reactor shall also be provided for the exhaust (or return) fan VFD.

Discharge Plenum

[SELECT ONE OF THE FOLLOWING HEAT/NO HEAT CONFIGURATIONS]

1. **Cooling Only:** For applications where no heat is required or heating is provided elsewhere within the building HVAC system, cooling only units include an empty discharge plenum. Supply duct connections are configurable for bottom, left, or right discharge. The supply air temperature sensor is included and factory-installed.
2. **Modulating Gas Heat:** For applications requiring gas heat for morning warm-up, supply air tempering, or other heating needs, a modulating natural gas furnace is available for finer temperature control. The furnace is located in the discharge plenum, downstream of the supply fan. The supply air temperature sensor is located across the face of the supply duct opening in the unit. Furnaces are designed in 375 mbh modules in 8:1 turndown increments. Three are available on the YPAL050-061 (8:1, 16:1, or 24:1 turndown). Ignition and safety controls are included and factory-wired. Units with modulating gas heat are UL listed.
3. **Modulating Hot Gas Reheat:** Modulating Hot Gas Reheat (HGRH) shall be provided. Design to include 3-way modulating valve and controller, a HGRH coil mounted downstream of evaporator coil, and all associated refrigerant piping. When dehumidification control is enabled, the compressors will be staged as needed to maintain the evaporator cooling coil setpoint. The Unit Controller will modulate the 3-way HGRH valve to control the amount of compressor discharge gas to the HGRH coil.

Guide Specifications (Cont'd)

4. **Staged Gas Heat:** For applications requiring gas heat for morning warm-up or other heating needs, a staged natural gas furnace is available. The furnace is located in the discharge plenum, downstream of the supply fan. The supply air temperature sensor is located across the face of the supply duct opening in the unit. Furnaces are designed in 375 mbh modules with two stages in each. Three modules are available on the YPAL050-061. Ignition and safety controls are included and factory-wired. Units with modulating gas heat are UL list.

Heat Exchanger: The heat exchanger shall be constructed of tubular aluminized steel [stainless steel], with stainless steel flue baffles and flue assembly.

Burner and Ignition Control: The burner shall include a direct-driven induced-draft combustion fan with energy efficient intermittent direct spark ignition, redundant main gas valves with pressure regulator.

Combustion-Air Fan: The inducer fan(s) shall maintain a positive flow of air through each tube, to expel the flue gas and to maintain a negative pressure within the heat exchanger relative to the conditioned space.

Safety Devices: A high-limit controller with automatic reset to prevent the heat exchanger from operating at an excessive temperature shall be included. An air-proving switch shall prevent ignition until sufficient airflow is established through the heat exchanger. A rollout switch shall provide secondary airflow-safety protection. The rollout switch shall discontinue furnace operation if the flue becomes restricted.

Flue: The furnace flue shall be shipped loose to protect it from damage during transit. The flue shall be field-mounted by the installing contractor. The flue outlet shall be located above the unit to help prevent recycling of combustion gases back through the heat exchanger. Agency Certification: Gas heating sections are both ETL/CETL approved to both US and Canadian safety standards.

Agency Certification: Gas heating sections are both ETL/CETL approved to both US and Canadian safety standards.

5. **Electric Heat:** An electric slip-in heater is installed within the rooftop unit discharge plenum to provide the heating requirements per the schedule shown on the plans. The electric heater is wired in such a manner as to provide a minimum of two steps of capacity.

Heat Exchanger: The furnace is an industrial grade design using an open coil made of the highest-grade resistance wire containing 80% nickel and 20% chromium. The resistance coils are adequately supported in the air stream using ceramic bushings in the supporting framework. Terminals of the coil are stainless steel with high temperature ceramic bushings.

Safety Devices: The primary high temperature protection is an automatic reset type thermal cut out. Secondary protection is an automatic reset type thermal cut out. Secondary protection is a replaceable thermal link.

Agency Certification: The operation of the electric heater is an integral part of the roof top control system. Power connection to the heater is through the power panel for the unit. Electric heat is ETL certified to both US and Canadian safety standards.

6. **Hot Water Heating Coil:** A hot water coil shall be installed in the rooftop unit discharge plenum.

Construction: The hot water coil shall have eight [10, 12, 14] fins per inch, 2 tubes per circuit, and an 2" inlet and outlet connection. Primary surface shall be 1/2" OD copper tube, staggered in direction of airflow. Connections have 1/4" FPT drain plug on each connection. A structural galvanized steel casing shall protect the coil. An intermediate coil support shall be provided. The coil shall be circuited to provide free draining and venting, through one vent and drain.

Testing: Completed coil, including headers, connections and return bends shall be tested with 325 pounds compressed air under water. Coils shall be designed for operation at 250 psig design working pressure.

7. **Steam Heating Coil:** A steam heating coil shall be installed in the rooftop unit discharge plenum.

Construction: The steam coil shall be constructed in the non-freeze style. The steam coil shall have six fins per inch, an 2" inlet, and 1 1/2" outlet connection. Tubes shall be 1" OD seamless copper tubing with a minimum wall thickness of 0.035" and expanded into the fin collars for maximum fin-tube bond. Inner distributing tubes shall be 5/8" OD seamless copper tubing with a minimum wall thickness of 1/4". All header connections shall be of red brass or steel, with male pipe threads and silver braze to headers. Casing shall be galvanized steel. The core shall be pitched in the direction of the condensate connection for proper drainage.

Testing: The completed coil, including headers and connections, shall be tested underwater with 325 lbs. compressed air to ensure a leak free coil.

8. **Diffuser Section:** For applications with an extended discharge plenum for downstream filtration, a diffuser section is provided. A diffuser shall be included to distribute the airflow from the fan evenly across the filter bank to optimize filter life and effectiveness. The diffuser shall be sized for 50% free area and provide adequate upstream and downstream clearance to minimize airside pressure drop.

Condenser Section

1. **Condenser Fans:** Condenser fans shall be matched up with compressors to optimize system control. Condenser fans shall be propeller-type, directly driven by permanently lubricated TEAO motor.
2. **Condenser Coil:** Condenser coils shall be seamless copper tubes, arranged in staggered rows, mechanically expanded into the end sheets. Coils are configured in a V-bank configuration, with individual flat coils rotated from the vertical plane for protection from hail damage for each condensing circuit. Condensing coils shall have a subcooler for more efficient, stable operation.
3. **Compressors:** Units shall use industrial-duty hermetic scroll compressors, piped and charged with oil and R-410A refrigerant. Compressors shall have an enlarged, liquid-carrying capacity to withstand rugged operating conditions. Compressor frame shall be cast iron, with cast-iron fixed and orbiting scrolls. Each compressor shall feature a line break, designed to protect the compressor from over-temperature and over-current conditions. Compressors shall be vibration-isolated from the unit, and installed in an easily accessible area of the unit. All compressor-to-pipe connections shall be brazed to minimize potential for leaks. Each compressor shall include an oil sight glass.
4. **Low Ambient:** Compressors shall operate down to 0°F Control [optional] by monitoring the refrigeration system discharge pressure and adjusting condenser airflow to maintain the proper head pressure to protect compressor operation.

Guide Specifications (Cont'd)

5. **In-Line Refrigerant Driers:** The optional replaceable core filter drier on the YPAL provides a convenient means for maintaining and optimizing the unit's refrigeration system. Eliminating additional field penetrations into the refrigerant circuit, which could lead to potential problems, reduce the worry of refrigerant circuit contamination.
6. **Condenser Wire Grill [optional]:** The condenser section shall be enclosed by a wire grill condenser enclosure on the three exposed sides. Plastic finish shall match the color and salt-spray specifications of the unit exterior.
7. **Hot-Gas Bypass:** Hot-gas-bypass piping shall be provided to enable compressor unloading to as low as 5% to better match cooling demand at low loads, prevent excessive cycling of the compressor, and reduce the risk of coil freeze-up.
8. **Compressor-sound treatment [optional]:** Compressor sound blankets shall be provided to attenuate radiated sound from the compressors.
9. **Service Valves [optional]:** Liquid, suction and discharge service valves shall be included to provide a means of isolating the refrigerant charge in the system so that the refrigeration system may be serviced without removing the charge of the unit.

Controls (Simplicity Elite) [optional]

1. **Enclosure:** Unit shall be shipped complete with factory-configured, installed, wired and tested unit controller housed in a rain-and-dust-tight enclosure with hinged, latched, and gasket sealed door.
2. **Basic Controls:** Control shall include automatic start, stop, operating, and protection sequences across the range of scheduled conditions and transients. The unit controller shall provide automatic control of compressor start/stop, energy-saver-delay and anti-recycle timers, condenser fans, and unit alarms. Automatic reset to normal operation after power failure. Software stored in nonvolatile memory, with programmed setpoints retained in lithium battery backed real time clock (RTC) memory for minimum 5 years.
3. **Diagnostics:** Upon demand, the controller shall run through a self-diagnostic check to verify proper operation and sequence loading. The unit controller shall continually monitor all input and output points on the controller and to maintain proper operation. The unit shall continue to operate in a trouble mode or shut down as necessary to prevent an unsafe condition for the building occupants, or to prevent damage to the equipment. In the event of a unit shutdown or alarm, the operating conditions, date and time shall be stored in the shutdown history to facilitate service and troubleshooting.

4. Controls and BAS Communications

(RS-485) Modbus: The unit shall include Modbus communications directly from the unit controller. Equipment that is not native to the unit.

A field installed Simplicity linc Gateway device is required by the manufacturer to communicate to BACnet (MSTP). A control points list shall be provided by the manufacturer to facilitate communications programming with the building automation system. Programming, establishing communications and commissioning shall be the responsibility of the installing controls contractor. Start-up assistance and support may be purchased from the manufacturer.

Analog inputs: 0-10VDC inputs shall be provided for remote reset of supply air temperature, and duct static pressure

Binary outputs: Dry (or “wet”) contacts shall be provided for alarm outputs for supply fan fault, cooling/ heating fault, or general/sensor faults. Contacts shall also be provided for occupied/unoccupied, shutdown, smoke purge, exhaust or pressurization operations; call for cooling or heating.

EXECUTION

Installation

General: Installing contractor shall install unit(s), including components and controls required for operation, in accordance with unit manufacturer’s written instructions and recommendations. Units shall be installed as specified.

1. Unit(s) specified shall include a protective covering membrane for such equipment being shipped by truck, rail, or ship. The membrane is fully formed around the equipment exterior. The membrane covers the entire top, side and end panel surface as to protect the product effectively during shipping & storage including “Long Term Storage”. Storing on jobsite shall no longer require the unit(s) to be covered with a tarp as long as the covering membrane has not been removed.
2. All size or shape equipment including electrical components, especially those not built with weatherproof enclosures, variable-frequency drives and end devices shall be effectively covered for protection against rain, snow, wind, dirt, sun fading, road salt/ chemicals, rust, and corrosion during shipping cycle. Equipment shall remain clean and dry.
3. Manufacturers of units not having a protective membrane, fully formed around the equipment exterior, covering the entire top, side and end panel surface area shall be required to ship equipment covered with a tarp, in crating or in a closed truck as is necessary to ensure product protection from road salt/ chemicals damage, moisture and dirt infiltration. Arrangements for long term storage at the job site shall be required.

Location: Locate the unit as indicated on drawings, including cleaning and service maintenance clearance per Manufacturer instructions. Adjust and level the unit on support structure.

INSPECTION AND START-UP SUPERVISION

A factory-trained service representative of the manufacturer shall supervise the unit start-up and application specific calibration of control components.

