

# Common Vent System Installation Manual

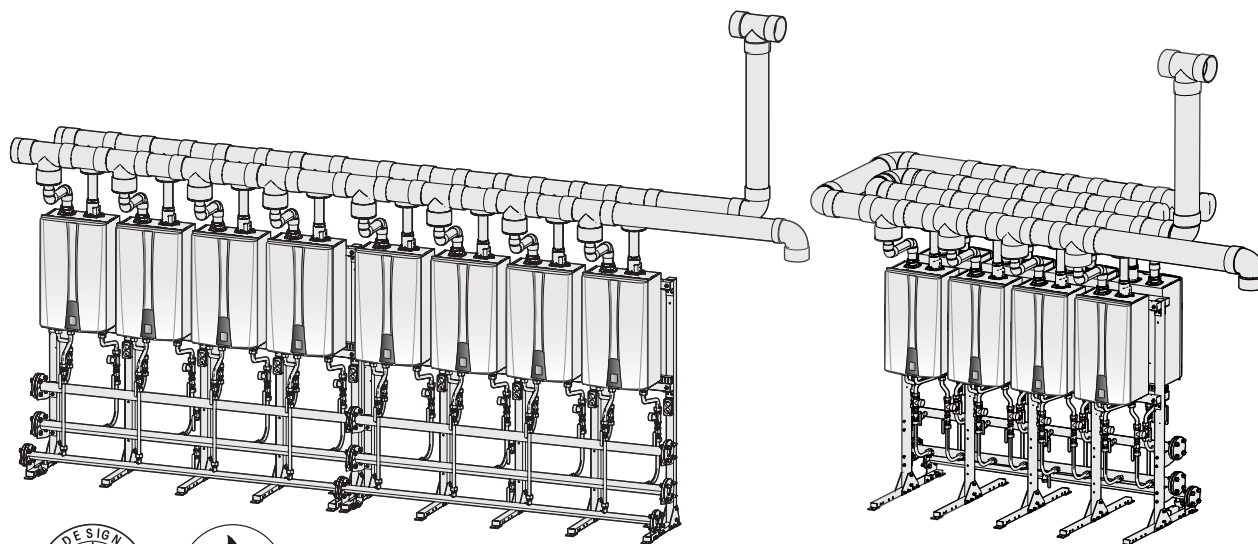

Independently tested and approved by CSA

Keep this manual for future reference whenever maintenance or service is required.

 **WARNING**

If the information in these instructions is not followed exactly, a fire or explosion may result, causing property damage, personal injury, or death.

- **Do not store or use gasoline or other flammable vapors and liquids in the vicinity of this or any other appliance.**
- **WHAT TO DO IF YOU SMELL GAS**
  - Do not try to light any appliance.
  - Do not touch any electrical switch; do not use any phone in your building.
  - Immediately call your gas supplier from a neighbor's phone. Follow the gas supplier's instructions.
  - If you cannot reach your gas supplier, call the fire department.
- **Installation and service must be performed by a qualified installer, service agency or the gas supplier.**
- **This entire manual must be left for the consumer. The consumer must read and refer to this manual for proper operation and maintenance of the common vent system.**
- **The installation must conform with local codes or, in the absence of local codes, the National Fuel Gas Code, ANSI Z223.1/NFPA 54.**

# Contents

---

<b>1. Safety Information</b>	<b>3</b>
<b>2. Common Vent System Information</b>	<b>5</b>
2.1 About the Common Vent System	5
2.2 Setting Up the Common Vent System	10
2.3 Navien Backflow Damper (Back-draft Damper)	12
<b>3. Installing the Common Vent System</b>	<b>13</b>
3.1 Starting the Common Vent System	13
3.2 Connecting and Terminating the Vent Pipe	15
<b>4. Common Vent Clearances</b>	<b>17</b>
4.1 Direct Vent Application – Vertical Installation	17
4.2 Direct Vent Application – Horizontal Installation	17
4.3 Exhaust Vent Termination Clearances (For Direct Vent)	18
<b>5. Installation Check List</b>	<b>19</b>
<b>6. Warranty Information</b>	<b>20</b>

# 1. Safety Information

The following safety symbols are used in this manual. Read and follow all safety instructions in this manual precisely to avoid unsafe operating conditions, fire, explosion, property damage, personal injury, or death.

## DANGER

Indicates an imminently hazardous situation which, if not avoided, could result in severe injury or death.

## WARNING

Indicates a potentially hazardous situation which, if not avoided, could result in injury or death.

## CAUTION

Indicates a potentially hazardous situation which, if not avoided, could result in property damage.

## DANGER

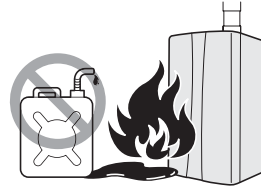

### If you smell gas:

- Do not try to light any appliance.
- Do not touch any electrical switches or use landline phones.
- From a neighbor's phone, call your gas provider and follow their instructions.
- If you cannot reach your gas provider, call the fire department.

### **Do not use or store flammable products, such as gasoline, solvents, or adhesives in the same room or area as the water heater or the boiler.**

- The water heater or boiler has a main burner flame that can turn on at any time and can ignite flammable vapors. Vapors from flammable liquids can explode and catch fire, causing death or severe burns.
- Vapors cannot be seen and are heavier than air. They can travel long distances along the ground and can be carried from other rooms to the main burner flame by air current.
- Keep all flammable products far away from the water heater or boiler and store them in approved containers. Keep the containers closed tightly and out of the reach of children and pets.



## WARNING

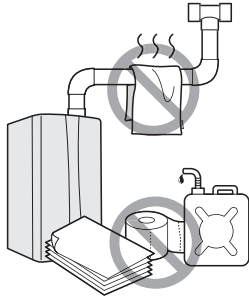

- **Do not store hazardous or flammable substances near the vent termination.**
- **Do not use unapproved replacement or accessory heater parts.**  
Doing so may result in improper or dangerous operation and will void the manufacturer's warranty.
- **Do not place anything in or around the vent terminals, such as a clothes line, that could obstruct the air flow in or out of the water heater or boiler.**
- **Do not combine the common vent with existing vents, chimneys, or the vent pipes connected to other types of water heaters, boilers, or appliances.**
- **Carefully follow all the installation instructions in the manual to avoid any personal and/or property damage.**  
Improperly installed common vent system may result in property damage or serious injury.
- **The common vent system is Category IV gas appliance.**  
Use only PVC or CPVC venting materials that satisfy Category IV venting requirements as well as schedule 40/80 specifications.
- **Do not install the water heaters or boilers in negative pressure conditions.**
- **Do not install the water heaters, boilers, venting, and vent terminals in areas that have contaminated air.**  
Doing so may cause operational problems.
- **Do not mix different model units within one common vent system. Model types of all the water heater or boiler units in a common vent system must be identical.**



## CAUTION

- Examine all components for possible shipping damage prior to installation.
- Use direct air vent installations only to avoid back drafting cold air through the water heater or boiler.
- The system must vent directly to the outside of the building and use outside air for combustion.
- Venting should be as direct as possible with a minimum number of pipe fittings.
- Create an airtight seal at each joint in the exhaust and intake air pipes from the water heater or boiler collar to the vent termination.
- Set the temperature setting to the same value on all water heaters or boilers that are sharing a common vent system.
- Ensure that all water heaters or boilers in the same system share the same intake and exhaust vent lines.
- Ensure that the vent diameter is not reduced by the common vent system.
- When using direct venting, maintain the following venting clearances, as required by **ANSI Z21.10.3 and the National Fuel Gas Code, ANSI Z223.1/NFPA 54.**
- Proper joint construction is essential for a safe installation. Follow these instructions exactly as written.
- This venting system must be free to expand and contract. This venting system must be supported in accordance with these instructions.
- Check for restricted vent movement through walls, ceilings, and roof penetrations.
- Different manufacturers have different joint systems and adhesives. Do not mix pipe, fittings, or joining methods from different manufacturers.

## 2. Common Vent System Information

### 2.1 About the Common Vent System

The Navien Common Vent System provides an easy way to install the vent system for up to 8 Navien NPE water heater or NHB boiler units. By sharing the main intake and exhaust vent pipes, effective system venting is available with less venting materials and minimal number of penetrations on the walls or roofing.

Read all safety messages and carefully follow the guidelines in this manual when installing a common vent system for the Navien NPE water heater or NHB boiler units.



#### WARNING

Improper venting of the water heater or boiler units can result in excessive levels of carbon monoxide, which can lead to severe personal injury or death. **The water heater or boiler units must be vented in accordance with the “Venting of Equipment” section of the latest edition of the ANSI Z223.1/NFPA 54 Natural Fuel Gas Code in the USA, as well as all applicable local building codes and regulations.** Follow all instructions and guidelines when venting the water heater or boiler units. Venting should be performed only by a licensed professional.

#### 2.1.1 Guidelines for a Common Vent System



#### CAUTION

- To ensure the correct operation of the common vent system,
  - a cascade communication cable **MUST** be installed between all units in the common vent system by the installer.
  - backflow vent dampers must be installed in the exhaust duct of each water heater or boiler unit.
  - **use direct vent systems** (with separate intake and exhaust lines).
- This manual covers the installation of a common vent system for **NPE water heaters and NHB boilers only.**

To ensure the safe and correct installation of the common vent system, carefully follow the instructions and guidelines.

- Check to see if all contents are included in the package (refer to the “Included Items” on page 12).
- A maximum of 8 NPE water heaters or NHB boilers may be connected to one common vent system. In a system that has more than 8 water heaters or boilers, use 2 common vent systems or consult Navien.
- Use only the PVC cements specified in this manual when connecting pipes, joints, or elbows.
- Position the water heater or boiler units as close as possible to the vent termination.
- Install a new vent system with this appliance. If an existing vent system is reused, thoroughly inspect it for punctures, cracks, or blockages prior to connecting it to the water heater or boiler unit.
- The common vent system covered in this manual is approved only for direct venting applications.
- Horizontal vent pipe runs must be supported every 4 feet (1.2 m) (minimum). All vertical vent pipe runs must be supported every 6 feet (1.8 m) (minimum). Support the vent pipe with hangers at regular intervals or as required by local codes.
- Install a backflow damper for each water heater or boiler unit. Use only the damper specified in this manual.
- To avoid moisture and frost build-up and to maintain clearances to openings on adjacent homes, 45° elbows, 90° elbows, or tees may be attached to the end of the termination vent pipe to direct the exhaust plumes away from buildings, as long as the total allowable vent lengths, maximum number of elbows, and distances to air intake restrictions are observed.
- If the water heater or boiler units will be installed in areas where snow is known to accumulate, protect the vent termination from blockage. Provide a minimum of 1 foot (30 cm) clearance from the bottom of the exhaust of the expected snow accumulation level. Snow removal may be necessary to maintain clearance.
- Ensure that the vent termination is at least 12 in (305 mm) above ground, 12 in (305 mm) above the highest anticipated snow level, or as required by local codes, whichever is greater.
- Support the vent pipe with hangers at regular intervals or as required by local codes.
- The vent for this appliance shall not terminate over public walkways; or near soffit vents or crawl space vents or where condensate or vapor could create a nuisance or hazard or cause property damage; or where condensate or vapor could cause damage or could be detrimental to the operation of regulators, relief valves, or other equipment.

## Clearances Between Multiple Units

Ensure that the installed water heaters or boilers satisfy all installation clearances provided in the manual. It is essential that there is sufficient clearance space for the common vent system to work properly.

The water heater or boiler units can be mounted either IN-LINE or BACK TO BACK.

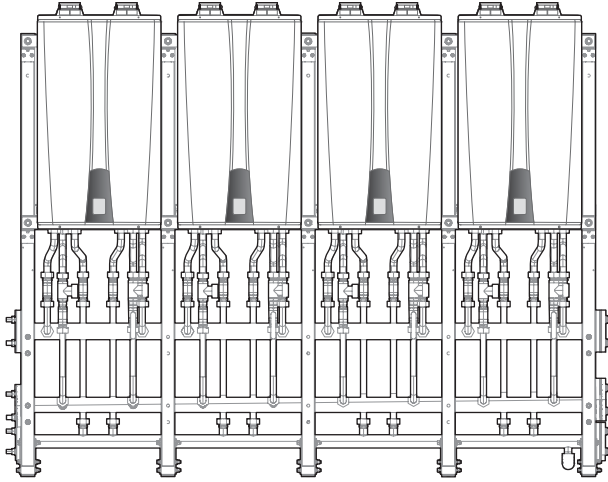

Navien Modular Configuration with Rack System

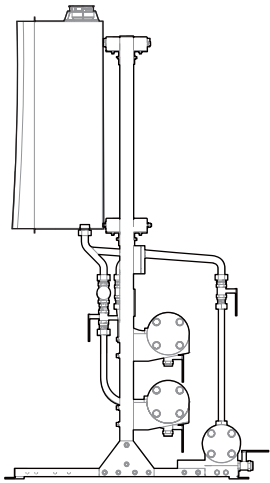

In-line Setup

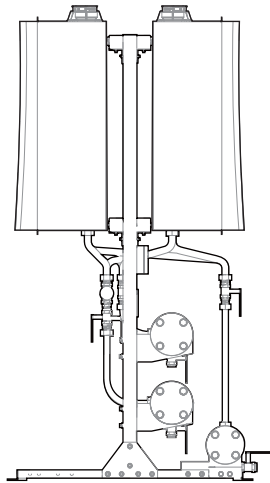

Back to Back Setup

## <Clearance Chart for Common Vent Applications>

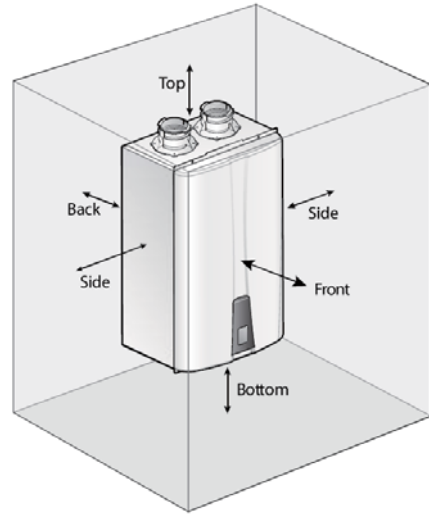

Bottom	12" (300 mm)
Back	0.5" (13 mm)
Side	3" (76 mm)
Front	24" (609 mm)
Top	36" (914 mm)

## **General and Local Standards Information**

When installing and operating the common vent system, the following standards and regulations must be complied with and adhered to:

- Local codes or, in the absence of local codes, the National Fuel Gas Code, ANSI Z223.1/NFPA 54.
- Appliance manufacturer's Installation Instructions.
- Regulations on the supervision of construction.
- Statutory provisions.
- Installation and service work must be carried out by licensed professionals only.

## **Risk Guidelines**

- Ensure that all common vent system components are manufactured and installed in accordance with valid standards, regulations, and safety engineering rules.
- To avoid risk, the common vent system must be installed and used only for the original purpose described in this manual.
- Defects or damages found in a common vent system must be addressed and repaired immediately.
- For roof or chimney modifications, refer to the relevant industrial safety regulations.
- Works on roofs and facades are dangerous. Comply with all relevant regulations.

## **Cutting and Assembling Common Vent System**

### **Components**

Standard tools are suitable for the cutting and assembly of common vent system components. Follow the guidelines listed below when working with the components.

- When cutting vent components, ensure that the cuts are straight. Chamfer and deburr all edges before installing the components.
- All vent joints must be fully tightened.
- Before operating the system, ensure that the installed vent system is clean and free of debris.
- Ensure that the vent system is rigidly supported according to the manual's instructions.

### **Selecting Vent Pipe Materials**

Consult the following chart or the most recent edition of ANSI Z223.1/NFPA 54, as well as all applicable local codes and regulations when selecting vent pipe materials. This appliance should be vented with materials approved for Category IV gas appliances. Do not use cellular core PVC (ASTM F891), cellular core CPVC, or Radel® (polyphenolsulfone) for the exhaust vent. See below for recommended vent materials.

<b>Locale</b>	<b>Recommended Vent Materials</b>
USA	<ul style="list-style-type: none"><li>• PVC Schedule 40 (Solid Core)</li><li>• CPVC Schedule 40 or 80 (Solid Core)</li></ul>

## Vent Pipe Pitch and Supports

For horizontal runs, slope the horizontal section upward toward the vent termination at a rate of 1/4" per foot (2% slope).

## Connecting Pipes with Cement

### CAUTION

The vapors from primers and solvent cements can make you dizzy and are dangerous to your health. Ensure that the work area is well ventilated, or wear an approved organic vapour respirator when working with primers and solvent cements.

To connect the vent pipes using cement:

1. Spread an even layer of solvent cement on the inside of the pipe fitting and the outside of the pipe.

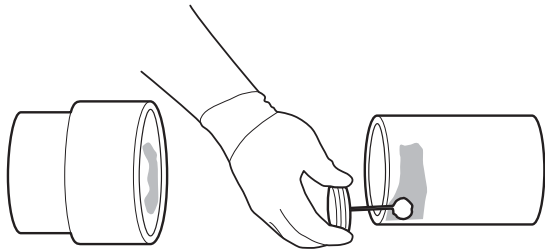

2. Align the pipe with the pipe fitting and twist the pipe a quarter turn as you insert it into the fitting. Twisting the pipe spreads the solvent cement evenly to ensure a solid joint.

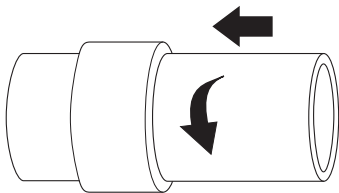

3. Hold the pipe and pipe fitting together for about 15 seconds until the cement sets.

### Note

- Use approved solvent type cement for the proper vent materials.
- Use solvent type cement only.
- Check the date of manufacture before using the cement. Ensure that cement was not manufactured more than 2 years prior to using it.
- Ensure that the inside of the pipe fitting and the outside of the pipe, where cement will be applied, is clean.
- Apply an even layer of cement over all mating surfaces.
- Use solvent cement in room temperatures higher than 32°F (0°C).
- Installing vent pipe with cement in cold ambient temperatures can result in longer cure times.

### DANGER

Be careful not to apply force or impact to pipes after making connections. An impact may break the bond and harmful gas might leak inside the room.



## 2.1.2 Determining the Length of a Common Vent System

Follow the instructions listed below to determine the length of a common vent.

1. Add the BTU/H input ratings for each unit in the cascading system to determine the total BTU/H rating.
2. Determine the total length (L) of the common vent, which consists of the horizontal width (W) and the vertical height (H):  
Total length (L) = W + H.

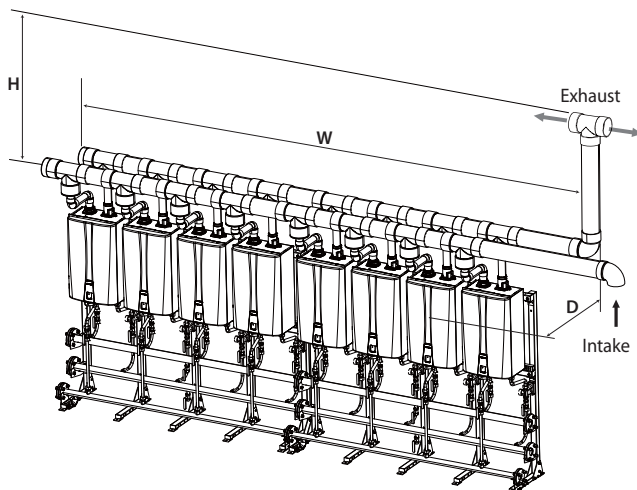

### Common Vent Length Table [Total Length (L) = W + H]

#### Vent Length for NPE Water Heater Units

Required Load (Total BTU/H)	Model	Total Length (ft)			
	NPE-240A/S	D=3"	D=4"	D=6"	D=8"
399,800	2	60	106	200	
599,700	3	40	71	160	
799,600	4	30	53	120	
999,500	5			96	150
1,199,400	6			80	142
1,393,300	7			68	121
1,599,200	8			60	106

**Note** Every 90° elbow used is equivalent to 8 linear feet (2.4 m) of vent length.

#### Vent Length for NHE Boiler Units

Required Load (Total BTU/H)	Model	Total Length (ft)			
	NHB-110/150	D=3"	D=4"	D=6"	D=8"
399,800	2	60	106		
450,000	3	40	71	160	
600,000	4	30	53	120	
750,000	5	24	42	96	
900,000	6		35	80	142
1,050,300	7		30	68	121
1,200,000	8		26	60	106

**Note** Every 90° elbow used is equivalent to 8 linear feet (2.4 m) of vent length.

### Example of a Typical Installation (Direct Vent Only)

The following illustration depicts an example of a common vent system installed for a cascade system of 8 Navien NPE heater units.

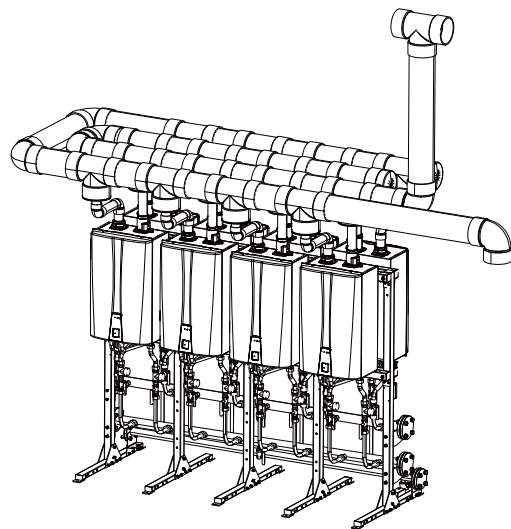

**Note** The illustration is intended for reference purposes only.

## 2.2 Setting Up the Common Vent System

### NPE Water Heater DIP Switch Settings



**DANGER**

Incorrect DIP switch settings may lead to severe personal injury, death, or property damage.

Refer to the following figures when setting DIP switches.

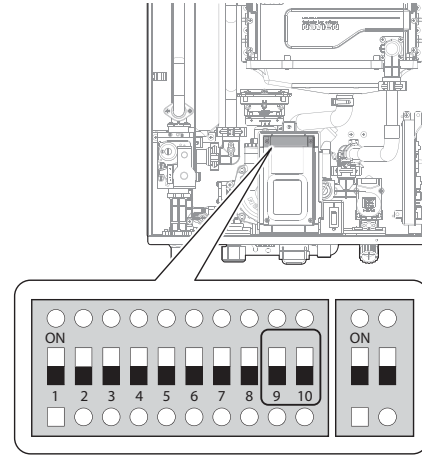
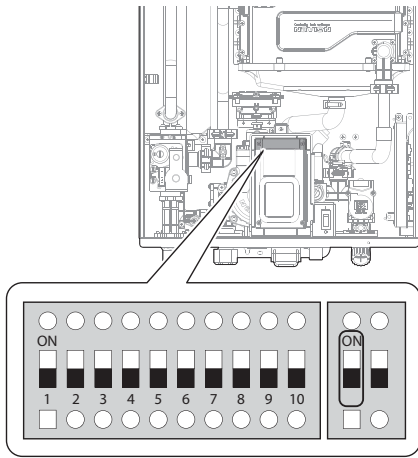

Switch (10-Switch DIP)	Function	Setting	
9 & 10	High Altitude Settings	0 – 1,999 ft (0 – 609 m)	9-OFF, 10-OFF
		2,000 – 4,500 ft (610 – 1,372 m)	9-ON, 10-OFF

**Note**

The NPE series water heaters may be installed at elevations up to 4,500 ft (1,372 m) for use with Natural Gas and Propane. To use the water heaters in the common vent system at a specific altitude, the DIP switches should be set as described above.

Switch (2-Switch DIP)	Function	Setting	
1	Cascade Vent Settings	Common Vent	1-OFF
		Individual Vent	1-ON

## NHB Boiler DIP Switch Settings



### **DANGER**

Incorrect DIP switch settings may lead to severe personal injury, death, or property damage.

Refer to the following figures when setting DIP switches.

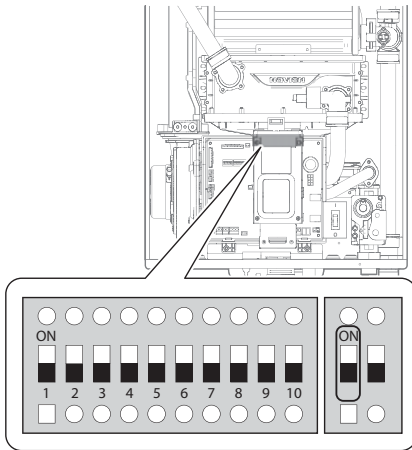

Switch (2-Switch DIP)	Function	Setting	
1	Cascade Vent Settings	Common Vent	1-OFF
		Individual Vent	1-ON





## 2.3 Navien Backflow Damper (Back-draft Damper)

The Navien backflow damper prevents backflow (back-draft) at the exhaust vent while the water heater or boiler unit operates.

By closing the exhaust vent as soon as the combustion cycle ends, the Navien backflow damper retains heat in the system for longer periods. This improves the system's thermal efficiency.

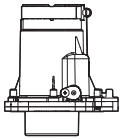
**Note** When using a common vent in a cascade system, backflow devices are required to prevent exhaust from entering the building.

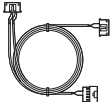
### Included Items

Backflow Damper	
Installation Manual	
Ready-Link communication cable	
Screw (4 ea)	

### Specifications

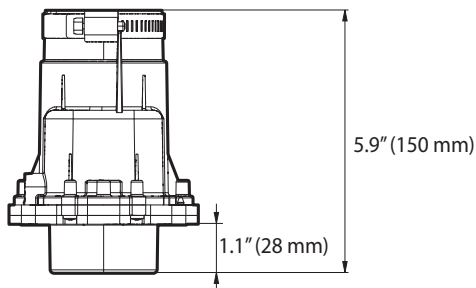

Part Name	Backflow Damper
Part No.	30014367A
Material	PP (Polypropylene)

### Maintenance Port

Navien Backflow Damper has a maintenance port to allow you to easily inspect the operating condition of the damper plate.

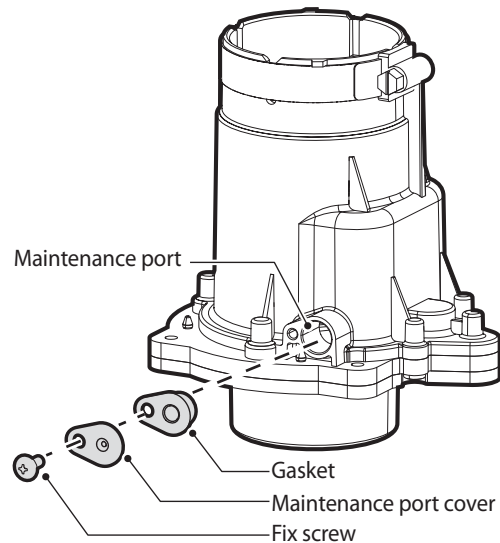
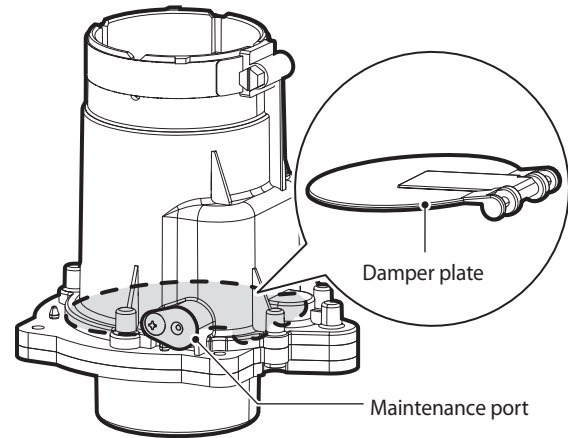

Refer to <3.2.3 Maintenance> for detailed inspection procedures. Navien Backflow Damper (Back-draft Damper)

**Note** When using a common vent in a cascade system, backflow devices are required to prevent exhaust from entering the building.

## 3. Installing the Common Vent System

### 3.1 Starting the Common Vent System

#### 3.1.1 Backflow Damper Assembly

Follow the instructions below to assemble the backflow damper on the NPE water heater or NHB boiler units:

1. Remove the screws from the exhaust vent adapter.

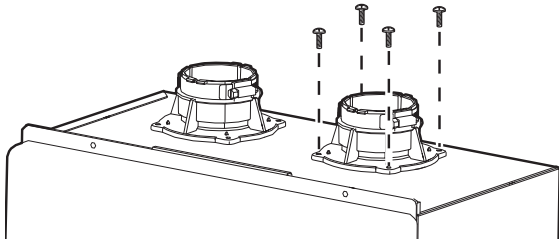

2. Detach the exhaust vent adapter.

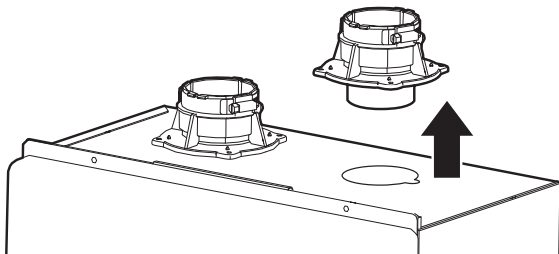

3. Connect the backflow damper to the exhaust duct of the water heater or boiler unit.

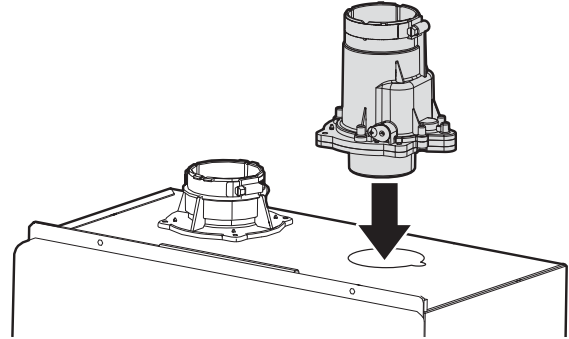

4. Tighten the four mounting screws to secure the backflow damper in place. The screws (x 4) are supplied with the backflow damper.

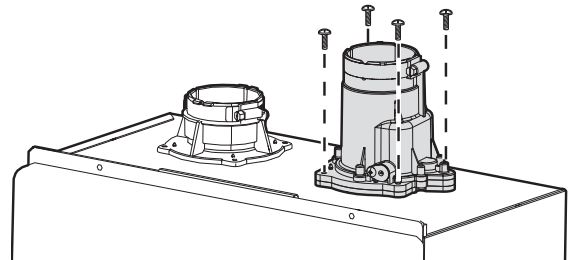

### 3.1.2 Connecting the Pipe to the Damper

1. Insert 2" vent pipe to the backflow damper to start the vent run.

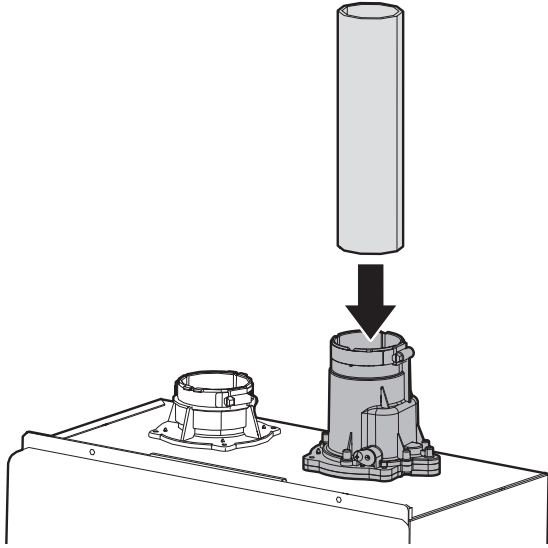

2. Completely slide the vent pipe ends into the transition fitting. Tighten the clamp with a screwdriver to properly seal the joint.

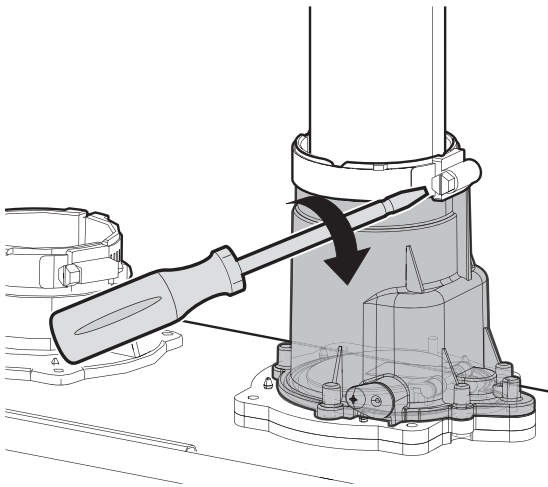

### 3.1.3 Assembling the T Joint

1. Connect an 8"-to-2" reducer to the 8" tee. Apply solvent cement to the mating surfaces.

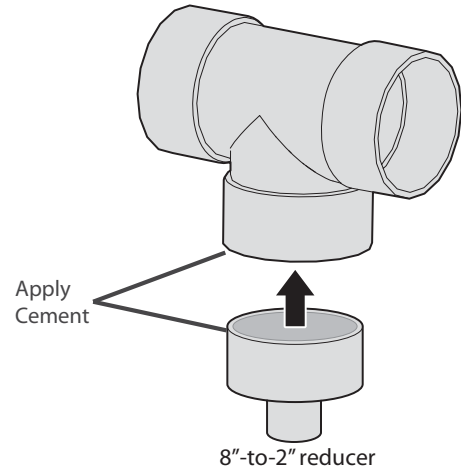

**Note**

Multiple reducers can be used to allow proper connection of 2" vent pipe to the common vent system.

2. Assemble the tee joint assembly (8"-to-2" reducer + tee joint) to the vent pipe. Apply solvent cement to the mating surfaces.

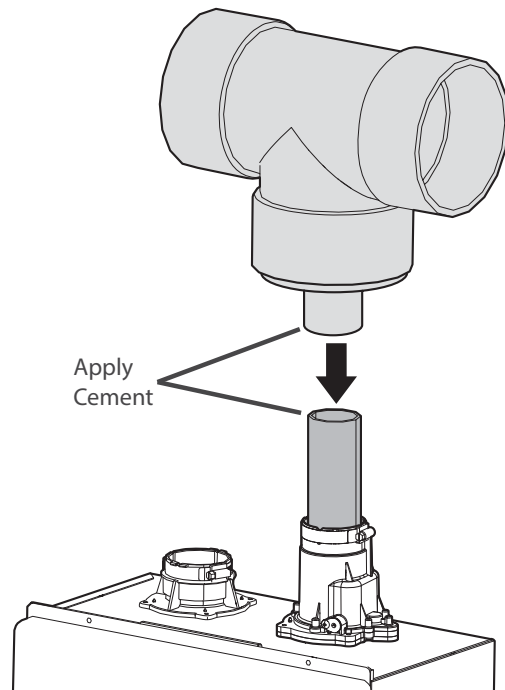

### 3.2 Connecting and Terminating the Vent Pipe

Refer to the following example to install the common vent system. The installation area should be measured to ensure that sufficient space is available to install the water heater or boiler units and the common vent system. Ensure that the common vent system is installed near the water heater or boiler units while satisfying all clearance requirements that are specified in this manual as well as the Installation Manuals supplied with the water heater or boiler units.

#### 3.2.1 Connecting the Main Pipe Runs to T Joint

After connecting the tee joint to the 8"-to-2" reducer, connect the main trunk pipe to each side of the tee. Each trunk pipe is connected to the other tee joint. Refer to <Connecting Pipes with Cement> on page 8 for more information.

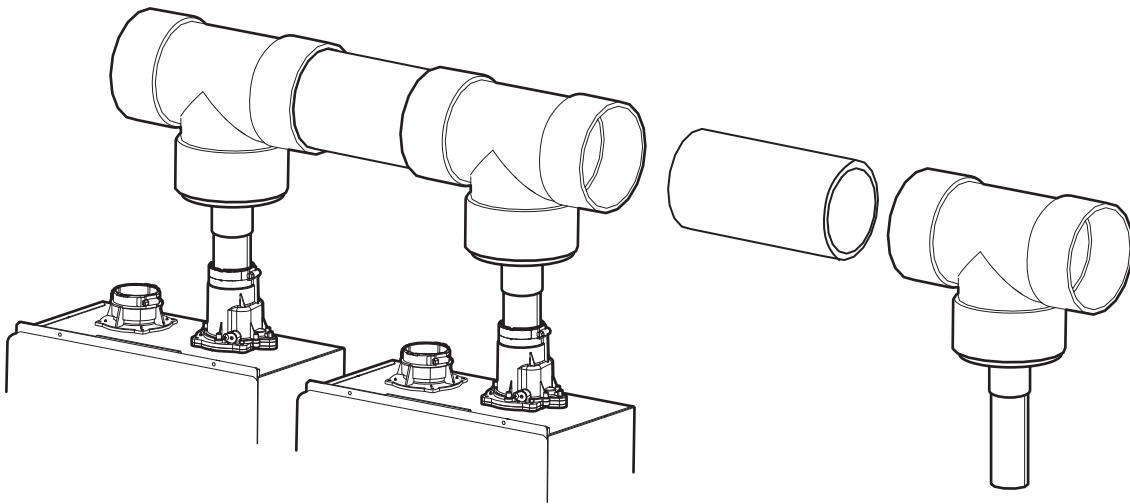

#### 3.2.2 Installing the System Termination

End caps, pipe elbows or tee joints can be used at the open ends of the intake and exhaust vent pipes. Refer to the following installation examples that depict how the parts are fitted at the end of the common vent system piping.

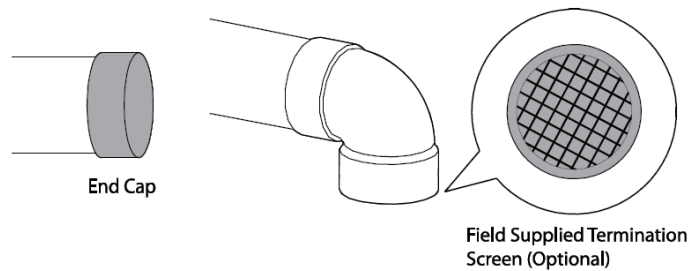

**Note**

The illustration is intended for reference purposes only.

### 3.2.3 Maintenance

Periodically check the damper condition inside the backflow damper through the maintenance port to ensure optimal performance of the system. Follow the instructions to check the damper condition and replace the backflow damper if necessary.

1. Remove the screw that fixes the maintenance port cover to the backflow damper, and then remove the gasket and the maintenance port cover.

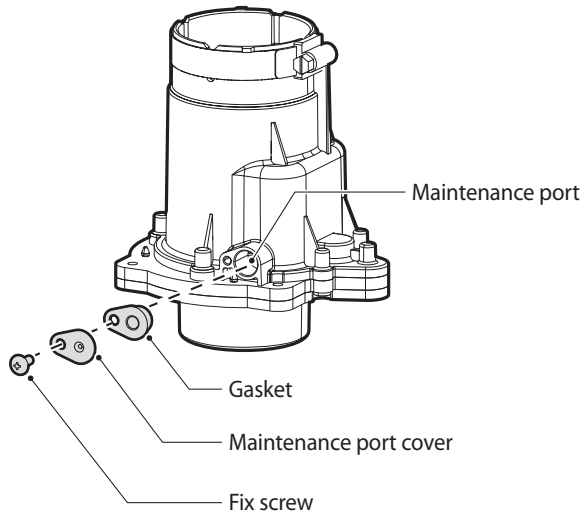

2. Through the maintenance port, check the operating condition of the damper plate inside the backflow damper.

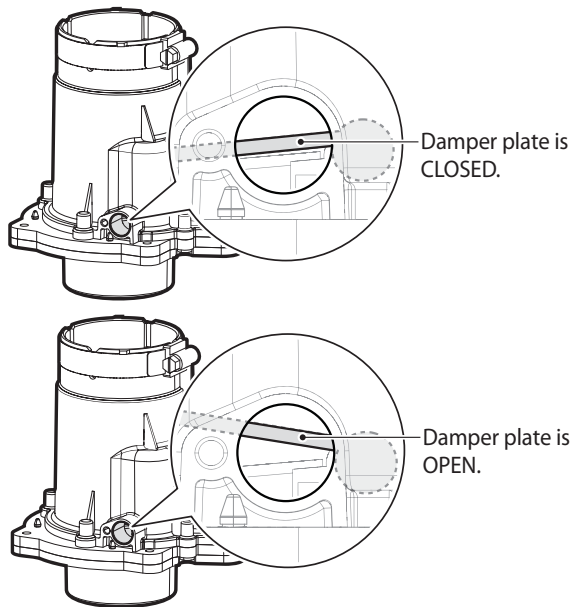

3. Reinstall the gasket and maintenance port cover, and then fix them with a set screw.

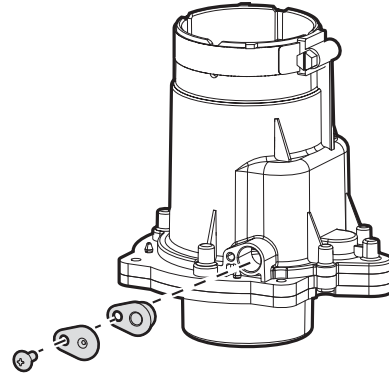

4. Visually inspect the maintenance port to ensure that the gasket is properly installed between the maintenance port and the maintenance port cover.

#### **WARNING**

Ensure that the gasket is properly installed under the maintenance port cover, after checking the operating condition of the damper plate through the maintenance port. Harmful exhaust gas may leak if the gasket is not installed, or if it is not installed properly.

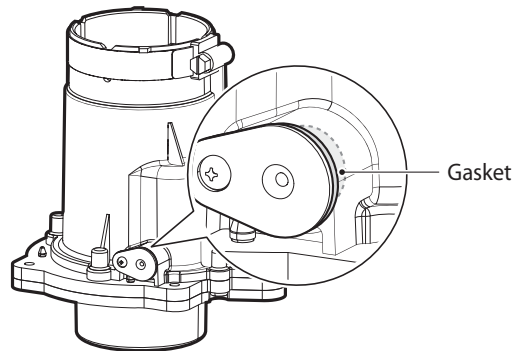



## 4. Common Vent Clearances

### 4.1 Direct Vent Application – Vertical Installation

#### 4.1.1 Direct Vent Application – Vertical Installation

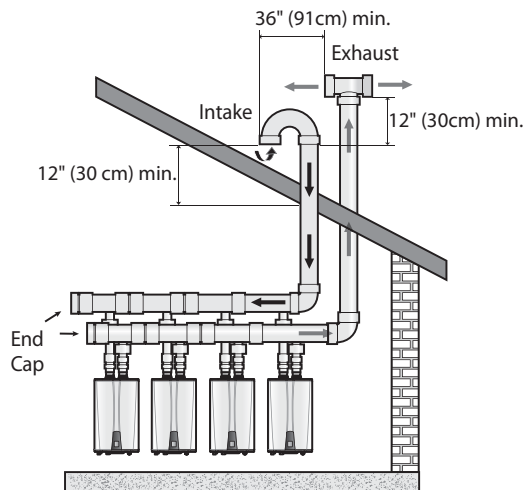

#### 4.1.2 Venting Intake and Exhaust to Different Locations

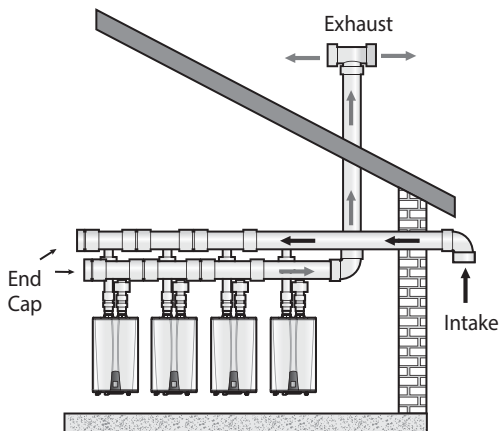

### 4.2 Direct Vent Application – Horizontal Installation

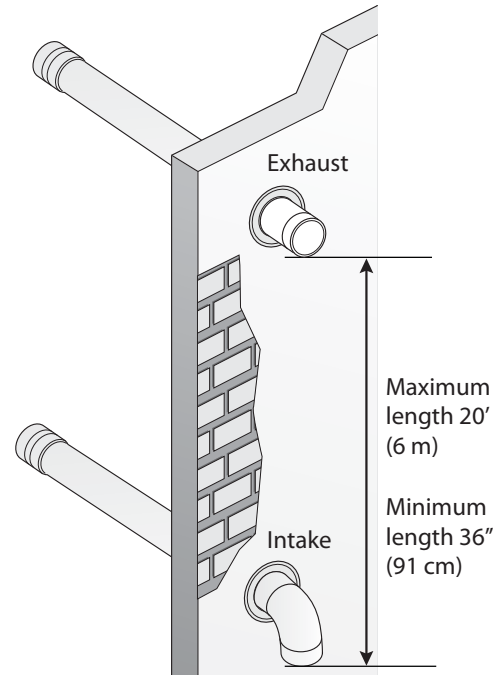

#### Note

- The illustration is intended for reference purposes only.
- Direct the exhaust away from any building openings.
- During cold weather situations, the temperature of the exhaust will be much warmer than the ambient air. Therefore, you will see water vapor being produced at the termination.

### 4.3 Exhaust Vent Termination Clearances (For Direct Vent)

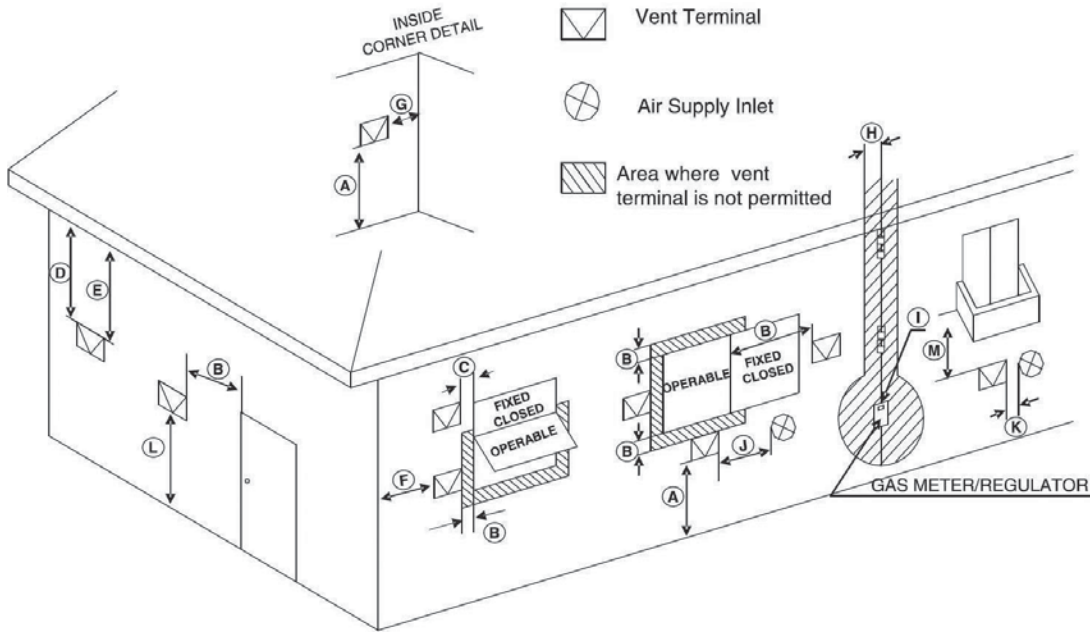

Ref	Description	Canadian Direct Vent Installations <sup>1</sup>	U.S. Direct Vent Installations <sup>2</sup>
A	Clearance above grade, veranda, porch, deck, or balcony	12 in (30 cm)	12 in (30 cm)
B	Clearance to window or door that may be opened	12 in (30 cm)	12 in (30 cm)
C	Clearance to permanently closed window	*	*
D	Vertical clearance to ventilated soffit located above the terminal within a horizontal distance of 2 feet (61 cm) from the center line of the terminal	*	*
E	Clearance to unventilated soffit	*	*
F	Clearance to outside corner	*	*
G	Clearance to inside corner	*	*
H	Clearance to each side of center line extended above meter/regulator assembly	3 ft (91 cm) within a height 15 ft above the meter/regulator assembly	*
I	Clearance to service regulator vent outlet	3 ft (91 cm)	*
J	Clearance to nonmechanical air supply inlet to building or the combustion air inlet to any other appliance	36 in (91 cm)	12 in (30 cm)
K	Clearance to a mechanical air supply inlet	6 ft (1.83 m)	3 ft (91 cm) above if within 10 ft (3 m) horizontally
L	Clearance above paved sidewalk or paved driveway located on public property	7 ft (2.13 m)†	*
M	Clearance under veranda, porch deck, or balcony	12 in (30 cm)‡	*

<sup>1</sup> In accordance with the current CSA B149.1 Natural Gas and Propane Installation Code

<sup>2</sup> In accordance with the current ANSI Z223.1 / NFPA 54 National Fuel Gas Code

† A vent shall not terminate directly above a sidewalk or a paved driveway that is located between two single family dwellings, that serves both dwellings.

‡ Permitted only if the veranda, porch, deck, or balcony is fully open on a minimum of two sides beneath the floor.

\* Clearance in accordance with local installation codes and the requirements of the gas supplier.

## 5. Installation Check List

After installing the water heater or boiler units and the common vent system, review the following checklist to ensure that the system has been properly installed. If you have additional questions or need assistance with the installation, contact Technical Support at 1-800-519-8794 or 1-949-420-0420, or refer to the technical support section of Navien's website ([www.navien.com](http://www.navien.com)).

<b>The water heater or boiler system</b>	<b>Yes</b>	<b>No</b>
Have you referred to the operation and installation manual that are supplied with the Navien water heater or boiler units for correct installation?		
Is there sufficient clearance around the water heater or boiler units?		
Does the installation comply with local codes or, in the absence of local codes, the National Fuel Gas Code, ANSI Z223.1/NFPA 54?		
Did you check that the cascade communication cable is properly installed?		
<b>DIP switch settings</b>	<b>Yes</b>	<b>No</b>
Did you verify that the appropriate DIP switch settings are selected for the cascade configuration?		
Did you verify that the correct DIP switch settings are selected for the altitude/elevation for the installation location?		
<b>The common vent system</b>	<b>Yes</b>	<b>No</b>
Have the correct venting parts been installed and have you followed the installation instructions in this manual?		
Did you verify that the vent system does not exceed the maximum equivalent length?		
Does the installation comply with local codes or, in the absence of local codes, the National Fuel Gas Code, ANSI Z223.1/NFPA 54?		
Did you check that all vent components are secure and fully engaged?		
Did you check that the vent is sloped upward toward the vent termination at a rate of 1/4" per foot (2° slope)?		
Did you check that there are no obstructions to the intake or exhaust vent air flow?		
Did you properly support the vent termination?		
Did you install end caps/termination caps on the exhaust and intake pipes?		
Did you check the venting for leaks?		
Is the vent termination at least 12 in (30 cm) above the exterior grade?		
Did you ensure that sufficient make-up air is available?		
<b>Hand-over procedures</b>	<b>Yes</b>	<b>No</b>
Did you explain the importance of not blocking the vent termination fittings or air intake to the customer?		
Did you explain the operation of the water heater or boiler units, safety guidelines, maintenance, and warranty to the customer?		
Have the system and appliance installation instructions been attached to the system or provided to the customer?		

If you have additional questions or need assistance with installation, contact Technical Support at 1-800-519-8794 or 1-949-420-0420, or refer to the technical support section of Navien's website ([www.navien.com](http://www.navien.com)).

## 6. Warranty Information

### Navien Limited Warranty

#### Warranty Period

Navien products come with a limited warranty. The following warranty periods begin to run from the date of original installation. The date of original installation must be provided to Navien, and upon request, proof of the original installation date must also be provided to Navien. When the product is installed in a new construction, the commencement date shall be dated upon which the end-user takes title to the property.

#### APPLICABLE WARRANTY PERIOD

Product	Parts Warranty
Navien Parts and Accessories	3 years

#### Warranty Claim Procedures

To obtain warranty repair service, the end user or homeowner must contact the original installer of your Navien product. If the original installer cannot be identified, the end user or homeowner may contact Navien's Technical Administration Department at **(800) 519-8794**. Proof of purchase is required to obtain warranty service.

#### Warranty Service

At its option, Navien will replace the defective component, in accordance with the terms of this Limited Warranty, if it fails in normal use and service during the applicable warranty period identified above. The replacement component must be Navien original factory component. Navien, at its sole discretion, may replace the component with a new or refurbished component of comparable quality and design. The replacement component will be warranted only for the unexpired portion of the original component's applicable warranty period. Payment for labor in completing the warranty service is subject to Navien's prior written approval and shall be subject to Navien's schedule of approved labor allowances.

#### Warranty Exclusions

Navien's Limited Warranty shall be void in the event of an occurrence of any of the following:

- Improper installation, failure to install in strict compliance with the Installation & Operation Manual procedures, installed by a non-licensed installer, and installation in violation of applicable rules, laws or building codes.
- Product purchased through the internet, other e-commerce channels, or any installer that obtained the product from a supplier or distributor not authorized by Navien.
- Failure to perform regular maintenance, misuse, operation at settings other than those recommended or specified, noncompliance with instructions or guidelines set forth in the User's Information Manual.
- Modification or alteration of the product in any manner, including but not limited to, removal of any component or part, addition of any non-approved components, relocating or moving the product from its original installation site, or any accidental or intentional damage to the Product.
- Installation for non-recommended uses.
- Any damage caused by local adverse conditions including but not limited to hard water deposits, lime or mineral build-up, operating in corrosive atmospheric elements.
- Damage or problems caused by gas flow issues, electrical surges, flooding, fire, abnormal external temperature, and any other cause of damage not directly caused by a manufacturing defect.
- Installer's failure to fully comply with the warranty service and return policy procedures previously provided to installer and as is available on Navien's website. Such policies include but are not limited to the installer's failure to first contact Navien Technical Support while in front of the product for purposes of trouble shooting the identified problem or issue.

- Performance problems caused by improper sizing of the water heater or boiler unit(s), the gas supply line, the venting connection, combustion air openings, electric service voltage, wiring, fusing or any other components, parts or specifications.
- Any damage, malfunction or failure caused by abuse, negligence, alteration, accident, fire, flood, freezing, wind, lightning and other acts of God.
- Operating, using or storing the water heater or boiler unit(s) in a corrosive or contaminated atmosphere or environment.
- Operating the water heater or boiler unit(s) at water temperatures outside the factory calibrated temperature limits and/or exceeding the maximum setting of the high limit control.
- Operating the water heater or boiler unit(s) when it is not supplied with potable water at all times.
- Subjecting the heat exchanger to pressures or firing rates greater or lesser than those shown on the rating plate.
- Installation at any location outside the United States and Canada.
- Removal or alteration of the rating plate.

**Other Terms:** This Limited Warranty is subject further to the terms and conditions set forth herein and as may be further specified in the terms and conditions page located on Navien's website at [www.navien.com](http://www.navien.com). WITH THE EXCEPTION OF THIS LIMITED WARRANTY, NAVIEN DISCLAIMS ANY OBLIGATION OR LIABILITY WITH RESPECT TO THE PRODUCTS OR THEIR SALE AND USE, AND NAVIEN NEITHER ASSUMES NOR AUTHORIZES THE ASSUMPTION OF, ANY OBLIGATION OR LIABILITY IN CONNECTION WITH THE PRODUCTS. THIS DISCLAIMER INCLUDES ANY OTHER WARRANTIES, EXPRESS, IMPLIED OR STATUTORY RESPECTING THE PRODUCTS OR ANY PARTS OR COMPONENTS THEREOF, INCLUDING, BUT NOT LIMITED TO, ANY IMPLIED WARRANTY OF MERCHANTABILITY OR FITNESS FOR A PARTICULAR PURPOSE. Navien's total liability for any claim arising hereunder shall not exceed the purchase price which you paid for the product. NAVIEN SHALL NOT IN ANY EVENT BE LIABLE FOR INDIRECT, SPECIAL, CONSEQUENTIAL OR LIQUIDATED DAMAGES OR PENALTIES, INCLUDING CLAIMS FOR LOST REVENUE, PROFITS OR BUSINESS OPPORTUNITIES, EVEN IF NAVIEN HAD OR SHOULD HAVE HAD ANY KNOWLEDGE, ACTUAL OR CONSTRUCTIVE, OF THE POSSIBILITY OF SUCH DAMAGES.

# *Memo*

---

**navien** Common Vent System

# Common Vent System Installation Manual

## Getting Service

If your common vent system requires service, you have several options for getting service:

- Contact Technical Support at 1-800-519-8794 or on the website: [www.navien.com](http://www.navien.com).  
For warranty service, always contact Technical Support first.
- Contact the technician or professional who installed your common vent system.
- Contact a licensed professional for the affected system (for example, a plumber or electrician).

When you contact Technical Support, please have the following information at hand:

- Model number
- Serial number
- Date of purchase
- Installation location and type

Version: 1.1 (Feb. 25, 2016)



Navien, Inc.

20 Goodyear Irvine, CA 92618 TEL 1-800-519-8794 FAX 1-949-420-0430 [www.navien.com](http://www.navien.com)