

# Installation & Maintenance Manual



R320  
R420

R-Series  
Indoor  
Residential  
Fireplace



## WARNING

If the information in these instructions is not followed exactly, a fire or explosion may result causing property damage, personal injury or death.



## WARNING

Do not store or use gasoline or any other flammable vapors and liquids in the vicinity of this or any other appliance.



## CAUTION

Installation and service must be performed by a qualified installer, service agency or the gas supplier.

## NOTICE

**Installer:** Leave this manual with the appliance.  
**Consumer:** Retain this manual for future reference.

## DANGER

### IF YOU SMELL GAS

- ⚠ Do not try to light any appliance.
- ⚠ Do not touch any electrical switch; do not use any phone in your building.
- ⚠ Immediately call your gas supplier from a neighbor's phone. Follow the gas supplier's instructions.
- ⚠ If you cannot reach your gas supplier, call the fire department.

## NOTICE

This fireplace is certified to ANSI Z21.50 / CSA 2.22 Vented Fireplace Standard as a power assisted direct vent fireplace. This product uses outdoor air for combustion and exhausts combustion products outdoors.



## DANGER



**HOT GLASS WILL CAUSE BURNS.  
DO NOT TOUCH GLASS UNTIL COOLED.  
NEVER ALLOW CHILDREN TO TOUCH GLASS.**

A barrier designed to reduce the risk of burns from the hot viewing glass is provided with this appliance and shall be installed for the protection of children and other at-risk individuals.



# NOTICE

You must read and understand this manual prior to installation, operation or troubleshooting this appliance. Please retain this owner's manual for future reference and maintenance.

## Table of Contents

Instruction Manual Contents		Section 7: Finishing the fireplace.....	28
Introduction.....	3	Finishing Around the Fireplace.....	29
Safety Alerts.....	3	Mantels & Surrounds.....	29
Section A: Before You Begin.....	4	Section 8: Removing & Installing Screen and Window.....	30
Introduction to the R-Series Fireplace:.....	5	Section 9: Installing the Firestones.....	31
Rating Plate Sample.....	6	Operation.....	32
Installation.....	7	Section 10: Cleaning and Maintenance.....	33
Section 1: Product Dimensions.....	7	Appendix A: Power Vent Locations.....	34
Section 2: Framing.....	10	PVVEX58-300 Vertical Power Vent Detail.....	34
Clearances:.....	10	Replacement Parts.....	35
Raised Installation:.....	11	Appendix A: Power Vent Locations.....	36
Installing the Fireplace:.....	12	PVVEX58-300 Power Vent Locations.....	36
Back framing the Fireplace.....	13	PVHFX58-300 Horizontal Power Vent Detail.....	37
Recessed Installation:.....	14	PVHFX58-300 Power Vent Locations.....	38
Section 3: Venting.....	15	PVHFL58-300 Horizontal Power Vent Detail.....	39
Section 3-1: Converting to Rear Vent.....	15	PVHIN58-300 Inline Power Vent with TMHIN58-40 Detail.....	41
Section 3-1-2: Converting the Pressure Sensing Tube and Air Baffle.....	16	Appendix B: Warranty.....	43
Section 3-2: Installing a Roof Mounted Vent System.....	17	Appendix C: State of Massachusetts.....	44
Section 3-3: Installing a Wall Mounted Vent System.....	19		
Section 3-3-1: Installing Wall Mounted Power Vent.....	20		
Section 3-4: Venting components.....	21		
Section 3-5: Heat Shields.....	22		
Section 4: Wiring.....	23		
Installing the Fireplace Control Box.....	23		
Installation of Electrical Supply.....	24		
Installing the Wall Switch.....	24		
Section 5: Installing the gas line.....	26		
Section 6: Testing the system.....	27		

## Safety Alert Key



### DANGER

Indicates a hazardous situation which, if not avoided, **WILL** result in death or serious injury or property damage.



### WARNING

Indicates a hazardous situation which, if not avoided, **COULD** result in death or serious injury or property damage.



### CAUTION

Indicates a hazardous situation which, if not avoided, **WILL** result in minor or moderate injury.

### NOTICE

Addresses practices that are important, but not related to personal injury

## Safety Alerts

### Introduction

Congratulations on your purchase of a **Montigo Fireplace**.

With over 30 years of experience, Montigo is committed to providing you with a gas fireplace that is not only a beautiful addition to your space, but that is also designed and manufactured to the highest safety, reliability and engineering standards.

We strongly encourage you to read and carefully follow the instructions laid out in this Installation, Operation and Maintenance Manual and retain it for your future reference. Pay special attention to all cautions, warnings, and notices throughout this manual intended to ensure your safety.

This manual covers installation, operation and maintenance. Lighting, operation and care of this fireplace can be easily performed by the homeowner. All installation and service work should be performed by a qualified or licensed installer, plumber or gas fitter as certified by the state, province, region or governing body where the fireplace is being installed.

This installation, operation and maintenance manual is applicable to the models described below. Refer to your rating plate to verify included options.

#### Warranty and Installation Information: (See Appendix B)

The Montigo warranty will be voided by, and Montigo disclaims any responsibility for, the following actions:

- ▶ Modification of the fireplace and/or components including Direct-Vent assembly or glass doors.
- ▶ Use of any component part not manufactured or approved by Montigo in combination with this Montigo fireplace system.
- ▶ Installation other than as instructed in this manual.

Consult your local Gas Inspection Branch on installation requirements for factory-built gas fireplaces. Installation & repairs should be done by a qualified contractor.

MODEL	Natural Gas	Liquid Propane	Gas Rating (BTU hr)	Linear Burner w/ Glass Accessories	Honeywell Hot Surface Ignition
R320N-I	X		50,000	X	X
R320L-I		X	40,000	X	X
R420N-I	X		65,000	X	X
R420L-I		X	55,000	X	X



### CAUTION

Young children should be carefully supervised when they are in the same room as the appliance. Toddlers, young children and others may be susceptible to accidental contact burns. A physical barrier is recommended if there are at risk individuals in the house. To restrict access to a fireplace or stove, install an adjustable safety gate to keep toddlers, young children and other at risk individuals out of the room and away from hot surfaces.



# Installation

## Section A: Before You Begin

### IMPORTANT MESSAGE: SAVE THESE INSTRUCTIONS

The R320\* & R420\* Power Vent fireplaces must be installed in accordance with these Instructions. Carefully read all the instructions in this manual first. Consult the Local Gas Branch to determine the need for a permit prior to starting the installation. It is the responsibility of the installer to ensure this fireplace is installed in compliance with the manufacturers instructions and all applicable codes.

### BEFORE YOU START:

## NOTICE

Installation and repairs should be done by an authorized gas fireplace service technician. The appliance should be inspected before use and at least annually by a professional. More frequent cleaning may be required due to excessive lint from carpeting, bedding material, etc. It is imperative that control compartments, burners and circulating air passageways of the fireplace are kept clean.



## CAUTION

Due to high operating temperatures, this appliance should be located out of traffic & away from furniture and draperies. Children and adults should be alerted to the hazards of the high surface temperature, which could cause burns or clothing ignition. Young children should be carefully supervised when they are in the same room as the appliance. Clothing or other flammable materials should not be placed on or near the appliance.



## DANGER

When this appliance is installed directly on any combustible material other than wood flooring, it must be installed on a metal or wood panel extending the full width and depth of the appliance or a fire will occur causing serious injury, property damage or even death.

### Installation Checklist

- Determine the desired install location of your fireplace.
- See Section 1, Dimensions and refer to the Framing Section 2 for details.
- Select your type and location of your Power Vent run: Roof Mounted (PVVEX58-300), External Wall Mounted (PVHEX58-300), Flush Louver Wall Mounted (PVHFL58-300). Inline Power Vent (PVHIN58-300) with flush louvered termination (TMHIN58-40).
- Your termination location should be selected to provide the most efficient vent run.
- Lay out the Vent run; calculating the required elbows and straight runs of 5"/8" flex and/or rigid pipe.
- Refer to the Section 3, "Venting" for details.
- Montigo supplies 20' of low voltage wire, which can be spliced to a maximum of 100' with wire of equal quality. This wire CANNOT run in conduit with any other wire.
- Refer to Section 4, for Wiring Details.
- The gas connection is located on the bottom right side (pilot burner side) of the fireplace.
- Refer to local codes and guidelines for installation requirements.
- Refer to Section 5, "Installing the Gas Line" for details.
- Installation and repairs should be done by a qualified contractor and must conform to:

• **Installations in Canada** must conform to the local codes or in the absence of local codes to the current version of Natural Gas and Propane Installation Code, CSA B149. Electrical Installations must conform to the local codes or, in the absence of local codes, to the current version of Canadian Electrical Code, CSA C22.1.1

• **Installations in the USA** must conform to the local codes or in the absence of local codes to the current version of National Fuel Gas Code, ANSI Z223.1/NFPA 54. Electrical Installations must conform to the local codes or, in the absence of local codes, to the current version of the National Electrical Code, ANSI/NFPA 70. See **Appendix C** for installation within the State of Massachusetts.



# Installation



## Introduction to the R-Series Fireplace:

The complete system will require a firebox, a power vent module, an electrical control panel, and a vent system. The appropriate vent system will connect the firebox to the power vent module and will be placed in a vertical or horizontal location. **The R-Series fireplace is not a heat efficient fireplace and should not be used with a thermostat to heat your home. This product is a fire feature and should only be used to enhance the ambiance of the room.** Please review the Installation Checklist on **Page 4** for general information on preparing for a successful installation of your fireplace.

### Install location:

The R-Series fireplace may be installed in any location that maintains proper clearances to air conditioning ducts, electrical wiring, and plumbing. Safety, as well as efficiency of operation, must be considered when selecting the fireplace location. Try to select a location that does not interfere with room traffic, has adequate ventilation, and offers an accessible pathway for Power Vent installation.

### Basic Operation:

The gas control components of this fireplace are located in the bottom of the firebox below the burner system. All models are supplied with a Honeywell smart valve gas control and do **NOT** have a variable flame control. There are two air switches that control the gas control system, located in the bottom of the firebox. These gas valves and pressure switches communicate with the electrical control panel through a six conductor cable supplied with the fireplace.

To operate the fireplace, Montigo supplies 20' of low voltage wire from the electrical control panel. Connect the two wire harnesses to a standard single pole ON/OFF switch to the location of your choice. You may extend these wires up to 100' in length with a wire of equal quality.

**CAUTION: Do NOT connect power to these wires.**

ON/OFF control of this appliance can also be performed using an optional remote control available from your Montigo dealer.



## WARNING

The **R320\*** & **R420\*** are classified under power vented fireplace systems. Under no circumstances can these models be installed without a Power Vent Module. For **Horizontal Vent Installations**, use 5"/8" Power Vent Motor PVH58-300, PVHFL58-300, or PVHIN58-300 with TMHIN58-40. For **Vertical Vent Installations**, use 5"/8" Power Vent Motor PVV58-300.

# Installation



## Rating Plate Sample

**Do Not Remove This Label / N'enlevez Pas Cette Étiquette**

**Do Not Remove This Label / N'enlevez Pas Cette Étiquette**

**Do Not Remove This Label / N'enlevez Pas Cette Étiquette**

**Type:**  Vented Gas Fireplace /  For Indoor Use

**Model No. / Modèle:** C-VIEW-R320-1

**Serial No.:** 2-150105-0000000000

**Manufacturer / Fabricant:** Canadian Heating Products Inc., Langley BC, www.montigo.com  
Montigo DelRay Corp., Ferndale, WA, www.montigo.com

**Tested To / Examiné A:** ANSI Z21.50-2014 / CSA 2.22-2014

**Electrical Rating / Estimation Électrique:** Power Vent 120V / 1Ph / 60Hz / Less than 12A

**Altitude Rating / Estimation D'Altitude:** N & H (0 - 4500 ft. / 0 - 1371 m).

**Fuel Type / Type De Carburant:**

N - Natural Gas / Gaz Naturel

LP - Propane / Gaz Propane

Max. Input / Max. Entrée BTU/H	Min. Input / Min. Entrée BTU/H	Output / Rendement BTU/H	Orifice Size / Taille D'Orifice Front/Avant Rear/Derrière	Gas Manifold Pressure / Pression D'Admission Du Gaz	Min. Gas Supply Pressure / Min. Pression D'Alimentation Du Gaz
50,000	50,000	N/A	3@47DMS / N/A	3.5" W.C.	5.5" W.C.
40,000	40,000	N/A	3@57dms / N/A	10" W.C.	11" W.C.



**\*Clearance to Combustibles / \*Degagements Aux Combustibles**

Sides / Côtés:	3
Back/Derrière:	2
Top-Top Vent/Du Haut-Évent Du Haut:	10
Top-Rear Vent/Du Haut-Évent Arrière:	10
Floor/Plancher:	0
Mantel/Manteau:	6
Recess Depth/Profondeur D'Encadrement:	20
Flue:	1

**FOR USE WITH GLASS DOORS AND SCREENS CERTIFIED WITH THE APPLIANCE ONLY**  
Pour utilisation avec portes de verre and écrans de certifiés avec l'appareil seulement

**\*Refer to installation manual for more information.**  
\*Référez-vous au manuel d'installation pour plus d'information.  
LBI.1207D-V5.0 R(P)VIEW\_HSL WITH SCREEN DEC.11.2014

Figure A: Rating Plate for R320

**Do Not Remove This Label / N'enlevez Pas Cette Étiquette**

**Do Not Remove This Label / N'enlevez Pas Cette Étiquette**

**Do Not Remove This Label / N'enlevez Pas Cette Étiquette**

**Type:**  Vented Gas Fireplace /  For Indoor Use

**Model No. / Modèle:** C-VIEW-R420-1

**Serial No.:** 2-150105-0000000000

**Manufacturer / Fabricant:** Canadian Heating Products Inc., Langley BC, www.montigo.com  
Montigo DelRay Corp., Ferndale, WA, www.montigo.com

**Tested To / Examiné A:** ANSI Z21.50-2014 / CSA 2.22-2014

**Electrical Rating / Estimation Électrique:** Power Vent 120V / 1Ph / 60Hz / Less than 12A

**Altitude Rating / Estimation D'Altitude:** N & H (0 - 4500 ft. / 0 - 1371 m).

**Fuel Type / Type De Carburant:**

N - Natural Gas / Gaz Naturel

LP - Propane / Gaz Propane

Max. Input / Max. Entrée BTU/H	Min. Input / Min. Entrée BTU/H	Output / Rendement BTU/H	Orifice Size / Taille D'Orifice Front/Avant Rear/Derrière	Gas Manifold Pressure / Pression D'Admission Du Gaz	Min. Gas Supply Pressure / Min. Pression D'Alimentation Du Gaz
65,000	65,000	N/A	4@47DMS / N/A	3.5" W.C.	5.5" W.C.
55,000	55,000	N/A	4@56dms / N/A	10" W.C.	11" W.C.

**\*Clearance to Combustibles / \*Degagements Aux Combustibles**

Sides / Côtés:	3
Back/Derrière:	2
Top-Top Vent/Du Haut-Évent Du Haut:	10
Top-Rear Vent/Du Haut-Évent Arrière:	10
Floor/Plancher:	0
Mantel/Manteau:	6
Recess Depth/Profondeur D'Encadrement:	20
Flue:	1

**FOR USE WITH GLASS DOORS AND SCREENS CERTIFIED WITH THE APPLIANCE ONLY**  
Pour utilisation avec portes de verre and écrans de certifiés avec l'appareil seulement

**\*Refer to installation manual for more information.**  
\*Référez-vous au manuel d'installation pour plus d'information.  
LBI.1207D-V5.0 R(P)VIEW\_HSL WITH SCREEN DEC.11.2014

Figure A: Rating Plate for R420

# Installation



## Installation

### Section 1: Product Dimensions

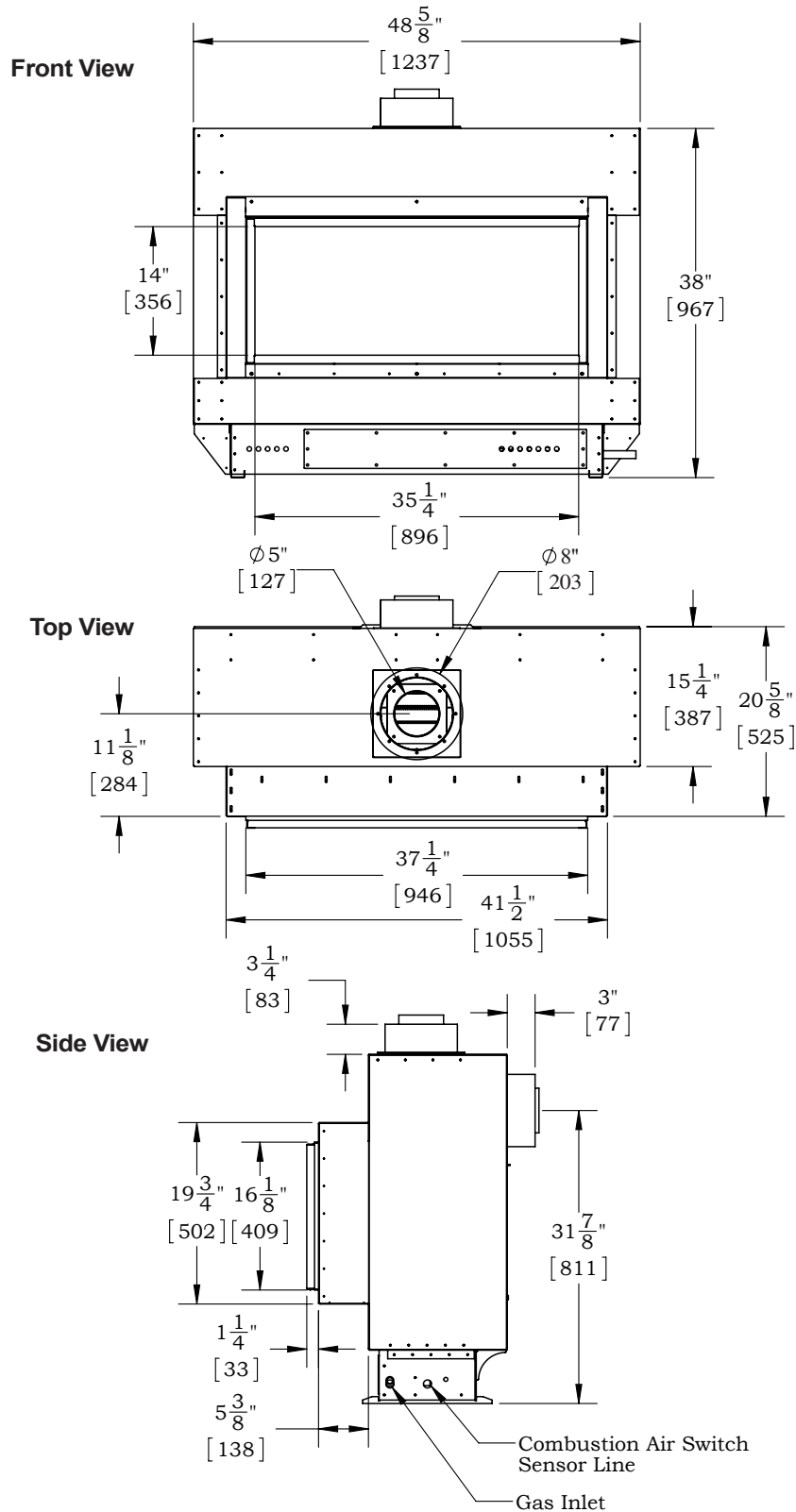

Figure 1. R320\* Fireplace dimensions (Tolerance  $\pm \frac{1}{8}"$ ).



# Installation

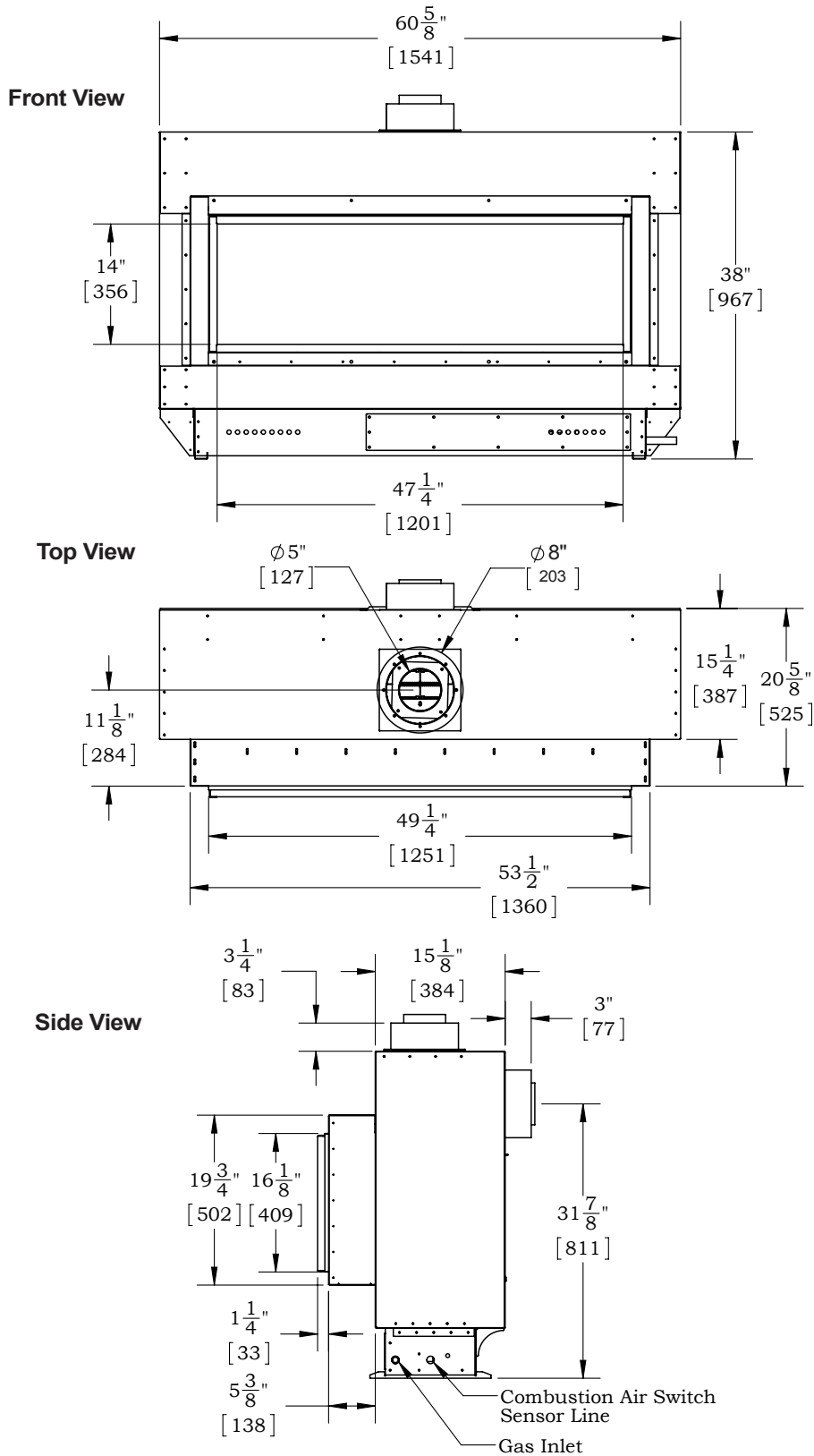

Figure 1a. R420\* Fireplace dimensions (Tolerance  $\pm \frac{1}{8}$ ").

# Installation

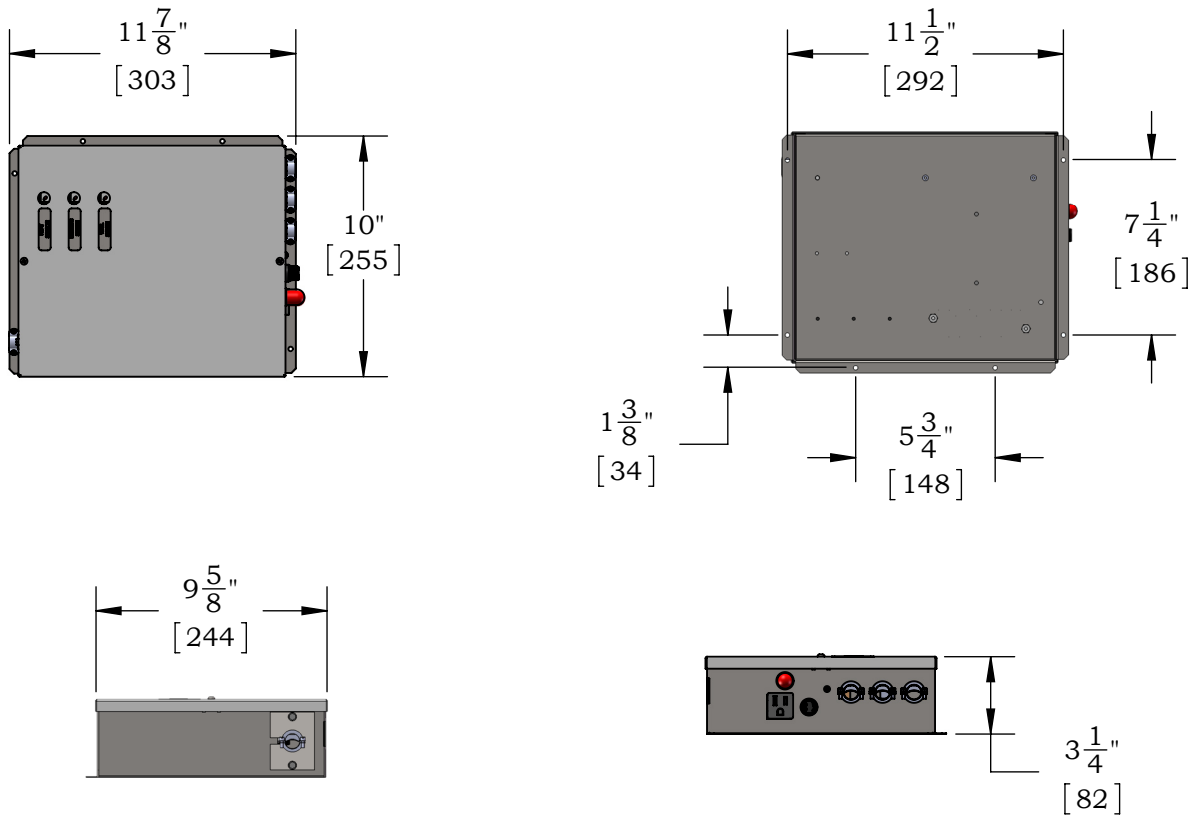

Figure 1b. R320\*-420\* Control Box Dimensions (Tolerance  $\pm \frac{1}{8}$ ").





# Installation

## Section 2: Framing

### Clearances:

To ensure the fireplace operates safely, all models must maintain the following clearances:

MODEL	Top - Rear Vent †	Top - Top Vent †	Rear - Top Vent	Rear - Rear Vent	Sides	Floor	Mantel
R320*	24	24	2	6	3	0	See Section 7 Finishing around the fireplace
R420*	24	24	2	6	3	0	

† **Note:** Clearance from top of fireplace to a combustible ceiling within the fireplace enclosure.

Unprotected combustible walls which are perpendicular to the fireplace opening must maintain 6" clearance, see **figure 20**.

Frame in the enclosure for the unit with framing materials, see **Figure 3**.

**NOTE:** When constructing the framed opening, please ensure there is access to install the gas line when the unit is installed. See **Figure 16**.

### Venting Clearance Requirements:

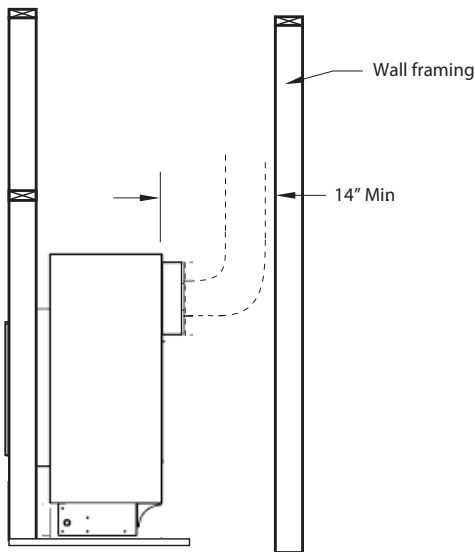

**Figure 2.** Clearances for rear vented installation with elbow.

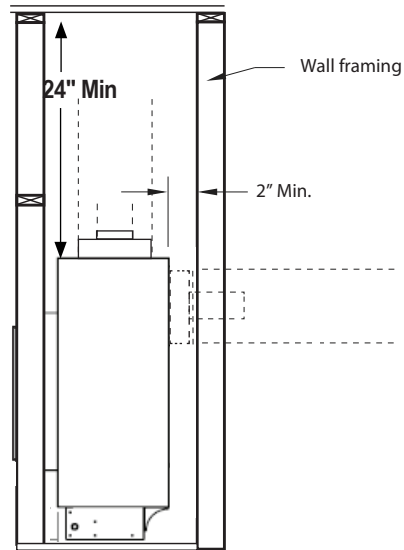

**Figure 2a.** Clearances for top or rear vented installation, straight vent run or with elbow(s).

## WARNING

When this appliance is installed directly on ANY combustible materials other than wood flooring (carpet, vinyl, etc), it must be installed on an equivalent wood or metal panel. This material must extend the full width and depth of the appliance.

**Note:** Images are shown without screens for clarity purposes. However, your fireplace should not be operated without proper installation of screens.

# Installation

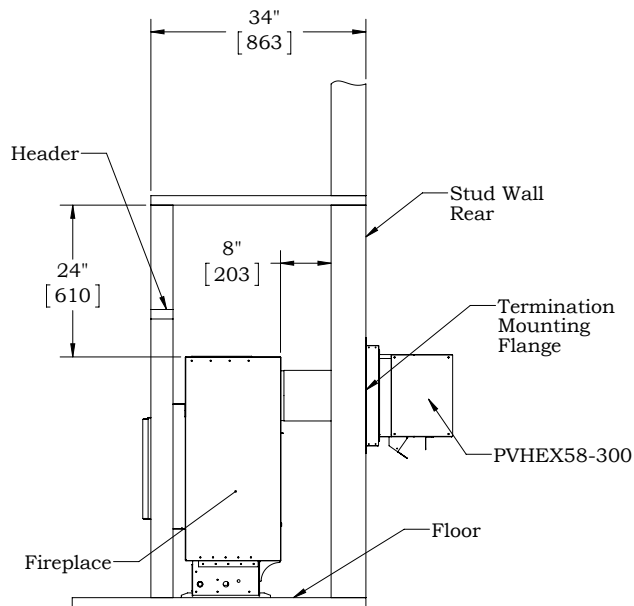
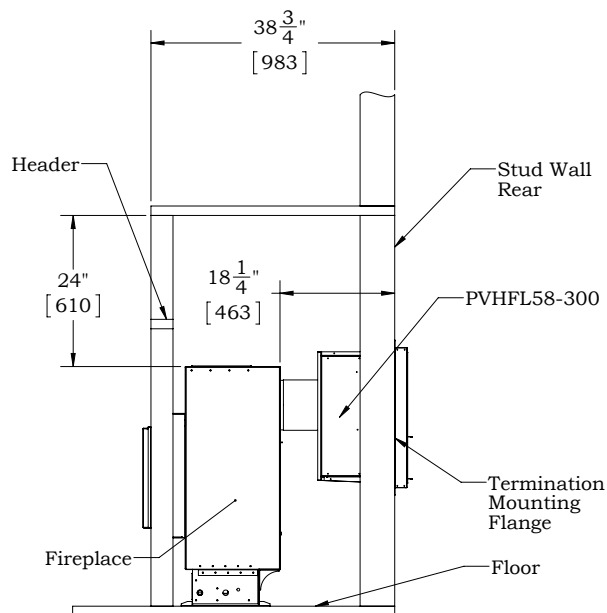

**Figure 2b.** Clearances for straight rear vented installation with PVHEX58-300.

**Note:** Images are shown without screens for clarity purposes. However, your fireplace should not be operated without proper installation of screens.

### Raised Installation:

Determine the height of the platform based on where you want the bottom edge of the glass to be, see **figure 1 or 1a** for unit dimensions. Maintain minimum ceiling height shown in table. Build fireplace frame as shown in **figure 3**.



**Figure 2c.** Clearances for straight rear vented installation with PVHFL58-300.

Maximum Platform Height	Minimum Required Ceiling Height
24"	8'
48"	10'

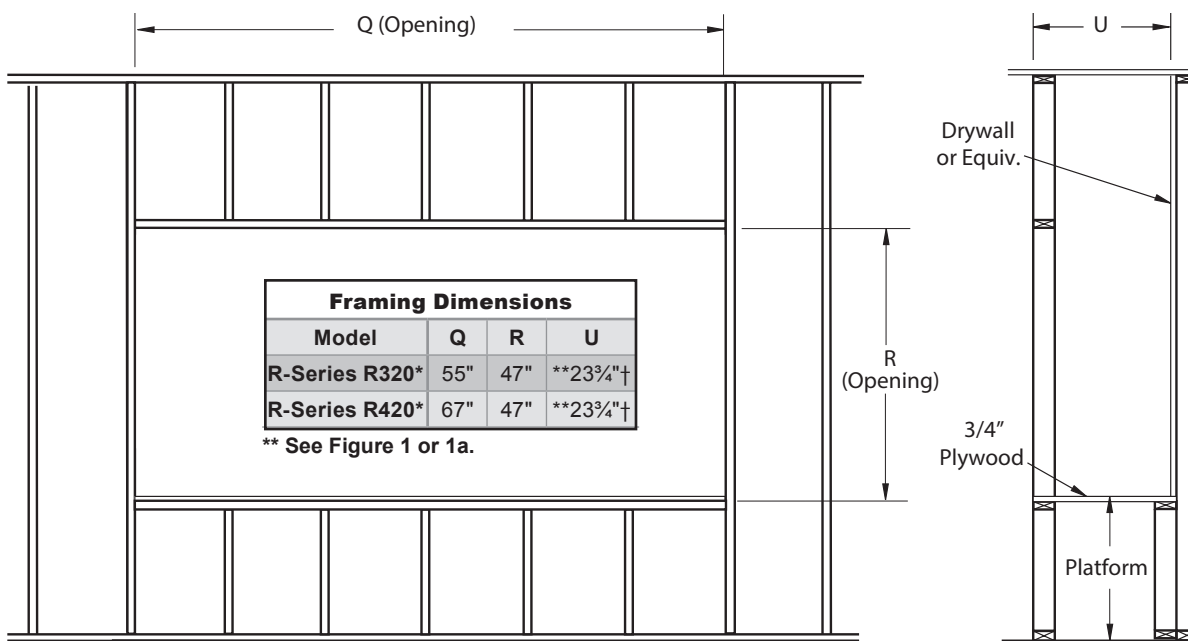

**Figure 3.** Fireplace installation, (Rough Frame-In dimensions).

† U is 29" for straight out the back vent run installations.



# Installation

## Installing the Fireplace:

Place the Fireplace on the platform and install the Vent pipe, and Power Vent module. Next, connect the Gas line, and provide a gas service shut-off valve; according to local gas codes. Before fastening in place, line up the front face of the fireplace (top and bottom), **Figure 4**. Then, secure in place with 1/4"bolts and washers to the platform.

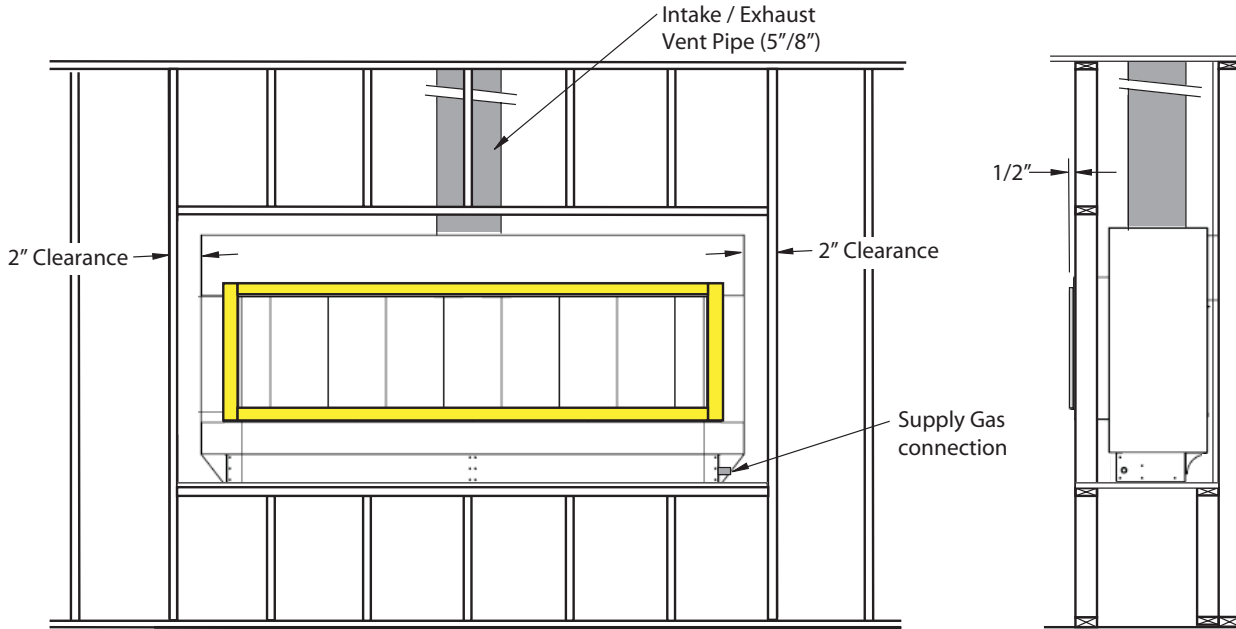

**Figure 4.**Fireplace installation, (*Inlet Gas & Power Vent*).

**Note:** Images are shown without screens for clarity purposes. However, your fireplace should not be operated without proper installation of screens.

# Installation



## Back framing the Fireplace

**NOTE:** Maintain a 1" clearance around the throat (projection at the front of the fireplace that holds the glass door) when installing 2x4s for back framing.

- Step 1).** Cut and install one 2x4 to fit horizontally under the fireplace throat.
- Step 2).** Cut and install required quantity of short filler 2x4's to fit vertically under the horizontal piece.
- Step 3).** Cut and install four vertical 2x4's. Place 2 on each side of the fireplace throat.
- Step 4).** Install supplied steel header 1" above the throat. Attach steel header to vertical 2x4's as shown in **figure 5**.
- Step 5).** Cut and install one horizontal 2x4 below the top frame.

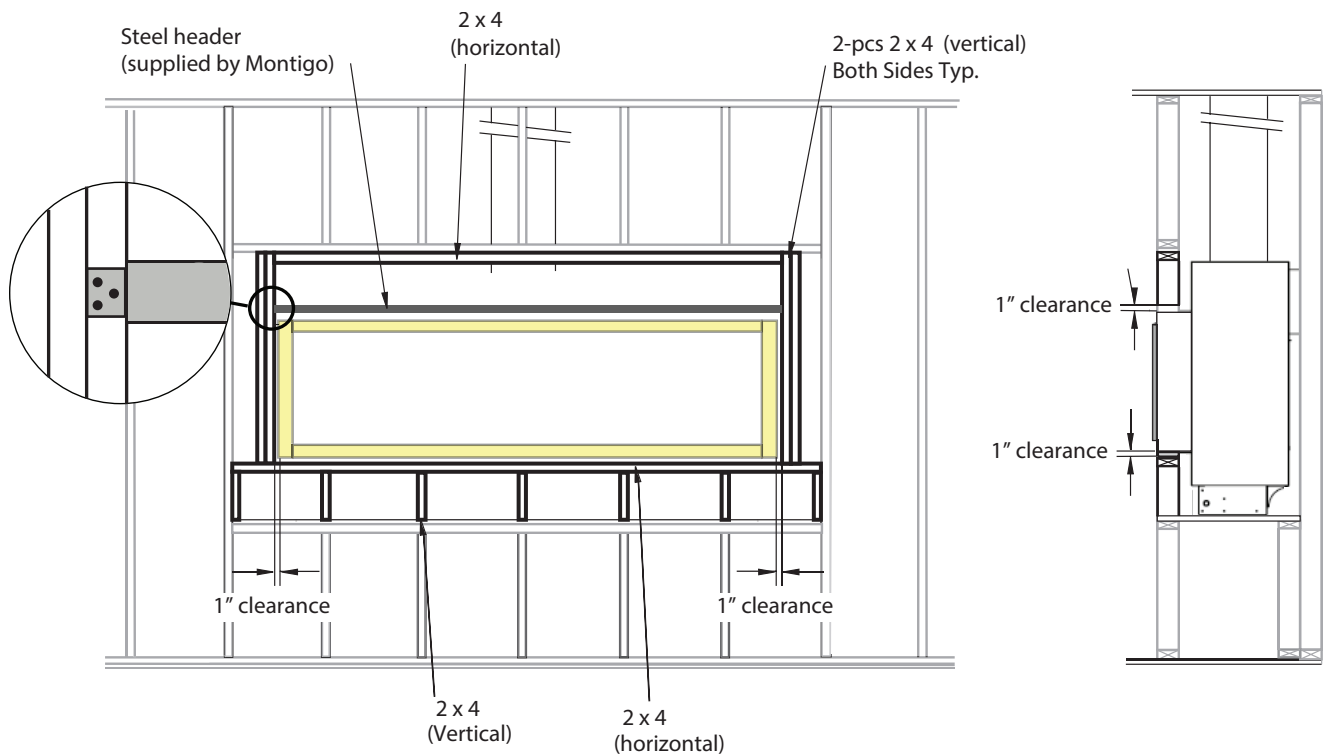

Figure 5. Completed back frame Fireplace installation

Model	Supplied Steel Header Measurements
R320*	46 1/2" x 3"
R420*	58 1/2" x 3"

**Note:** Images are shown without screens for clarity purposes. However, your fireplace should not be operated without proper installation of screens.



# Installation

## Recessed Installation:

This fireplace can be recessed into the floor to get the viewing area as low as possible.

Maintain a minimum of 6" clearance from the bottom of glass to completed floor. Minimum clearance can be reduced to 3" for uncarpeted flooring. Discolouration may occur due to high temperatures.

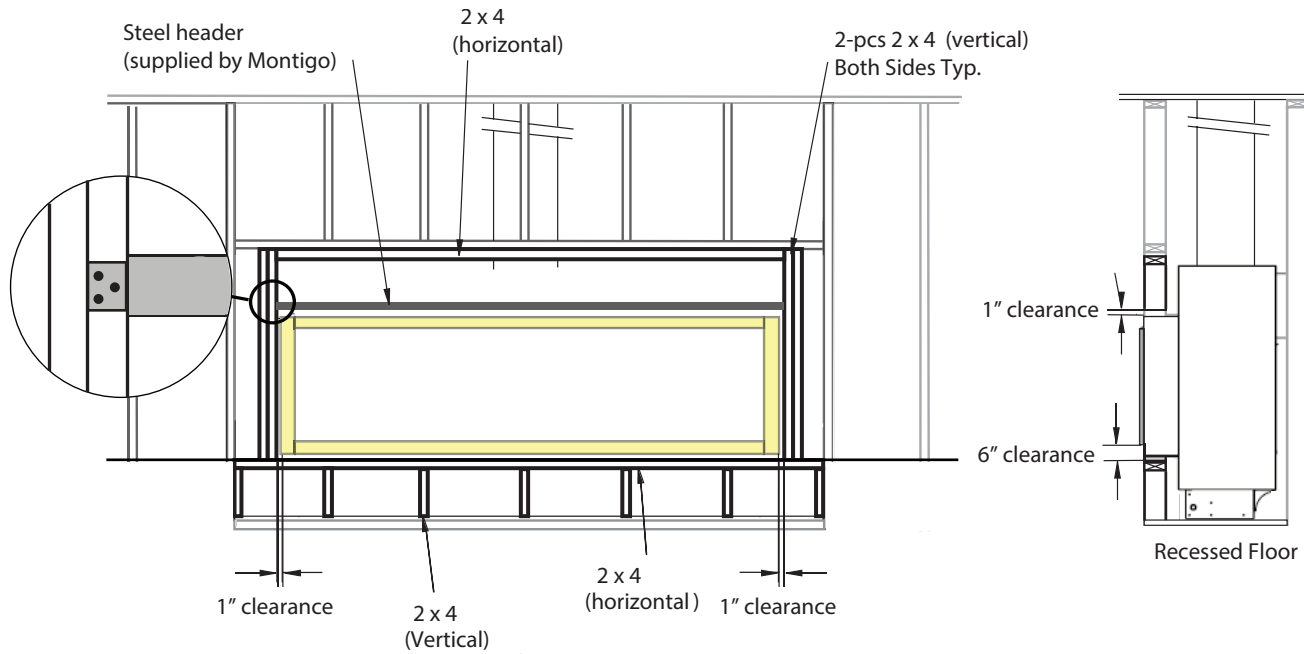

Figure 6. Recessed Fireplace installation

**Note:** Images are shown without screens for clarity purposes. However, your fireplace should not be operated without proper installation of screens.



# Installation



## Section 3: Venting

Montigo supplies a variety of power venting options. The location of the power vent should be selected and laid out to provide the most efficient possible run to an external wall or through the roof.

### Notes For Planning Venting:

- R-Series fireplaces are Power Vent Designated.
- Venting originates from the top or rear of the unit.
- Venting can terminate through the roof or exterior wall.
- For a detailed diagram of allowed termination locations, see **Appendix A**.
- Once the termination location has been established refer to the appropriate section for installation details.
- All fireplaces are shipped Top Vent from the factory.
- Follow the chart on page 15 or page 19 for maximum ventrun and maximum elbows.

## Section 3-1: Converting to Rear Vent

R-Series units are shipped for Top Vent installations. Follow the instructions to convert unit for Rear Vent installation.

### Section 3-1-1: Converting the Flue

1. Remove the Rear flue cover with gasket (5" and 8") on .. the flue outlet, as shown in **Figure 7**. **ENSURE YOU DO NOT DAMAGE THE FIBRE GASKETS.**
2. Remove the Top flue collar (5" and 8") on the flue outlet, as shown in **Figure 7**. **ENSURE YOU DO NOT DAMAGE THE FIBRE GASKETS.**

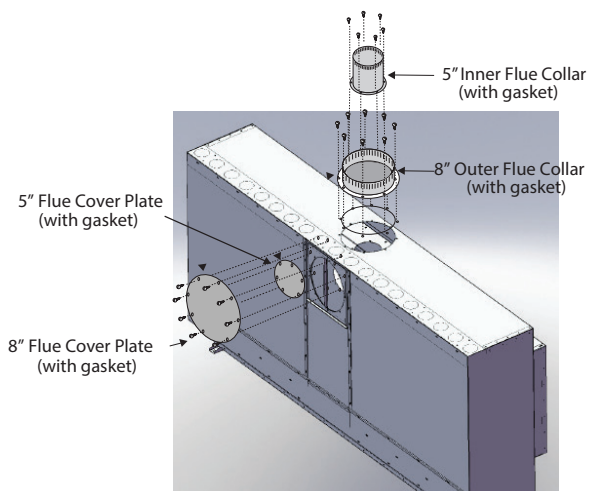

**Figure 7.** Flue cover and collar removal, Top Vented fireplace

3. Install the removed Rear flue cover (5" and 8") to the Top Vent outlet. Fasten the cover with included hardware, as shown in **Figure 7a**.
4. Install the collars (5" and 8") to the rear vent outlet using the included hardware, as shown in **Figure 7a**.

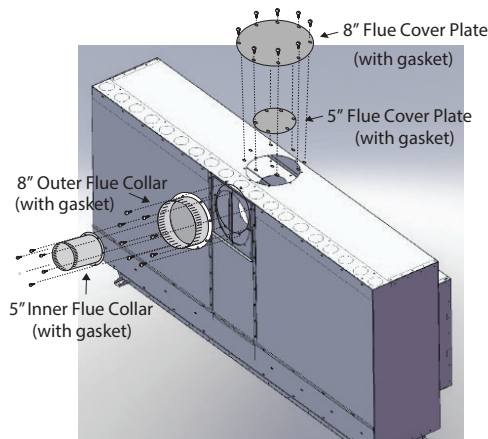

**Figure 7a.** Flue cover and collar installation, Rear Vented fireplace

5. Proceed to Section 3-1-2: Converting Pressure Sensing Tube and Air Baffle.



# Installation

## Section 3-1-2: Converting the Pressure Sensing Tube and Air Baffle

When the **R320\*/R420\*** is converted from Top Vent to Rear Vent, the pressure sensing tube must be removed and replaced with supplied Rear Vent pressure sensing tube and air baffle must be relocated as described below.

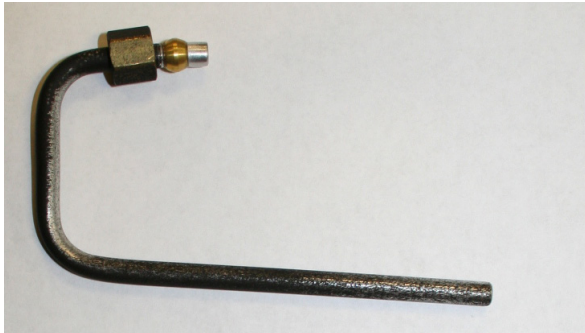

**Figure 8.** *Factory installed Top Vent Pressure Sensing Tube*

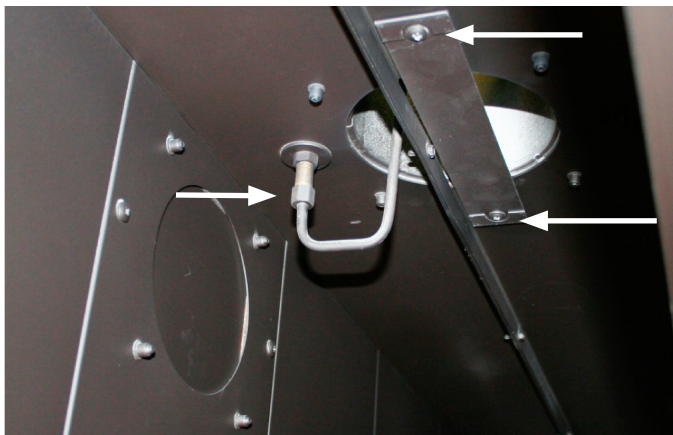

**Figure 8a.** *Supplied Rear Vent Pressure Sensing Tube*

1. Remove two screws from the air baffle installed over the Top Vent from inside the firebox. Once air baffle is removed, replace the two screws back into the same position.

**Note:** Not all models are equipped with an air baffle. Only convert if available.

2. Remove Top Vent pressure sensing tube but loosening the compression nut with a 1/2" wrench.

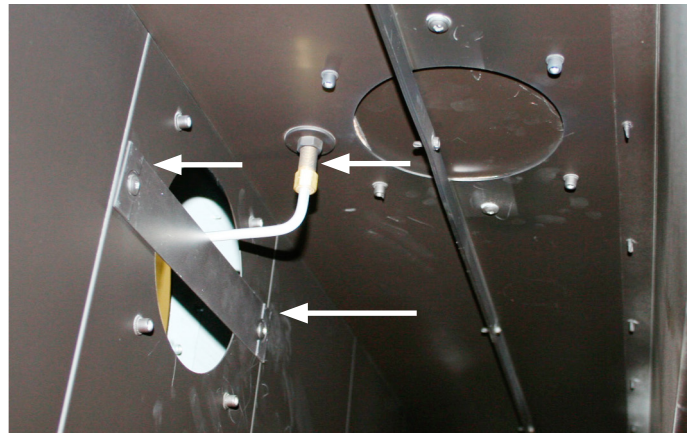

**Figure 9.** *Removal of Top Vent air baffle and pressure sensing tube.*

3. Position the supplied Rear Vent pressure sensing tube as shown in **Figure 9a**. Hand tighten the compression nut by hand and then a half-turn with a wrench.

**Do not over tighten.**

4. Install air baffle over Rear Vent from inside the firebox with two screws provided at the Rear Vent.



**Figure 9a.** *Removal of Top Vent air baffle and pressure sensing tube.*

**NOTE:** Rear vent pressure sensing tube is shipped inside the control box.

# Installation



## Section 3-2: Installing a Roof Mounted Vent System

This section applies to installations where the most efficient vent run is through the roof. Refer to **Appendix A - Power Vent locations**, to ensure the planned Power vent location is acceptable. Refer to the table below for vent run requirements.

Vent Configuration	Refer to Figure	Maximum Vent Run (Horizontal + Vertical)	Maximum Elbow†
Straight Vertical Top or Rear Vent	Figure 10	100 Feet	Six 90° or equivalent †
Multi-Elbow Top or Rear Vent	Figure 10a		
Multi-Elbow with 6' downward vent run Top or Rear Vent	Figure 10b	70 Feet**	

† One 90° elbow is equal to two 45° elbows.

\*\* For every additional 1 foot downward vent run subtract 10 feet from the maximum vent run.

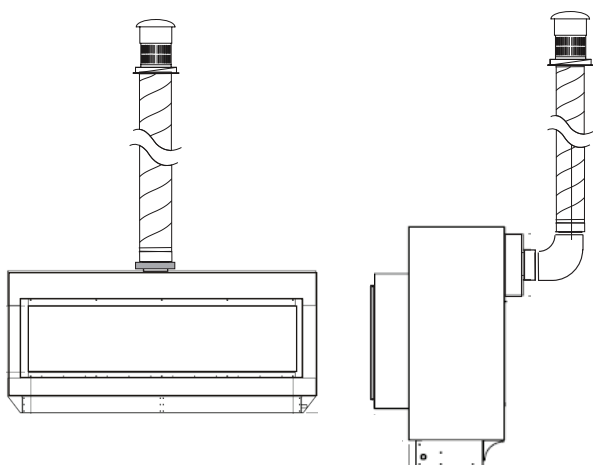

**Figure 10.** *Straight Vertical, Top or Rear Vent, Roof mounted power vent.*

**Note:** Images are shown without screens for clarity purposes. However, your fireplace should not be operated without proper installation of screens.

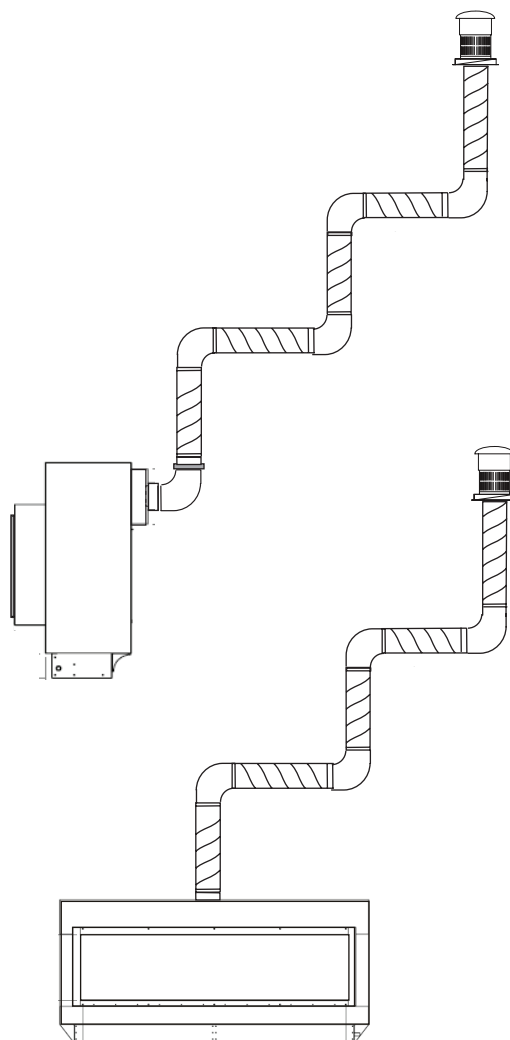

**Figure 10a.** *Multi-Elbow, Top or Rear Vent, Roof mounted power vent.*



# Installation

## Section 3-2-1: Installing Roof Mounted Power Vent PVVEX58-300

Note: See Power Vent manual for installation instructions.

Note: See Appendix A for clearance to exterior structures.

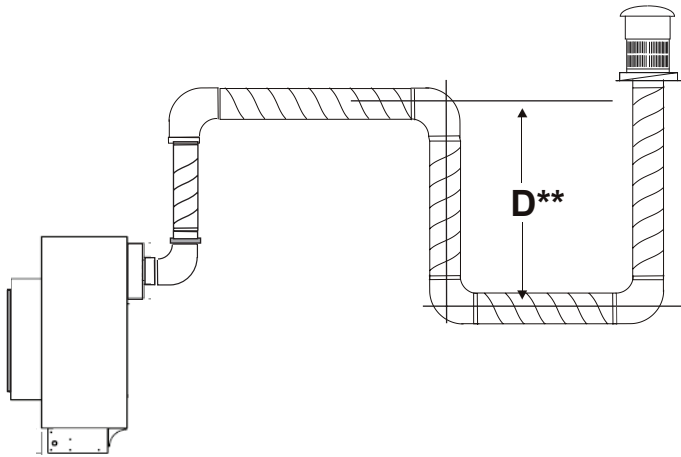
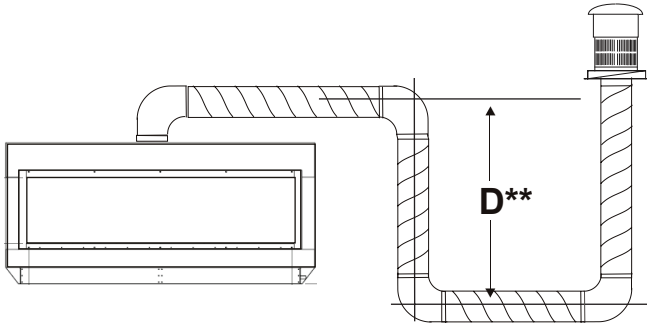

**Figure 10b.** Multi-Elbow with downward vent run, Top or Rear Vent, Roof mounted power vent.

**Note:** Images are shown without screens for clarity purposes. However, your fireplace should not be operated without proper installation of screens.

# Installation



## Section 3-3: Installing a Wall Mounted Vent System

This section applies to installations where the shortest possible vent run is through the wall. Refer to **Appendix A - Power Vent locations**, to ensure the planned Power vent location is acceptable. Refer to the table below for vent run requirements. **Please note**, images are shown without screens for clarity purposes. However, your fireplace should not be operated without proper installation of screens.

Vent Configuration	Refer to Figure	Maximum Vent Run (Horizontal + Vertical)	Maximum Elbows†
Straight Horizontal Top or Rear Vent	Figure 12	100 Feet	Six 90° or equivalent †
Multi-Elbow Top or Rear Vent	Figure 12a		
Multi-Elbow with 6' downward vent run Top or Rear Vent	Figure 12b	70 Feet**	

† One 90° elbow is equal to two 45° elbows.

\*\* For every additional 1 foot downward vent run subtract 10 feet from the maximum vent run.

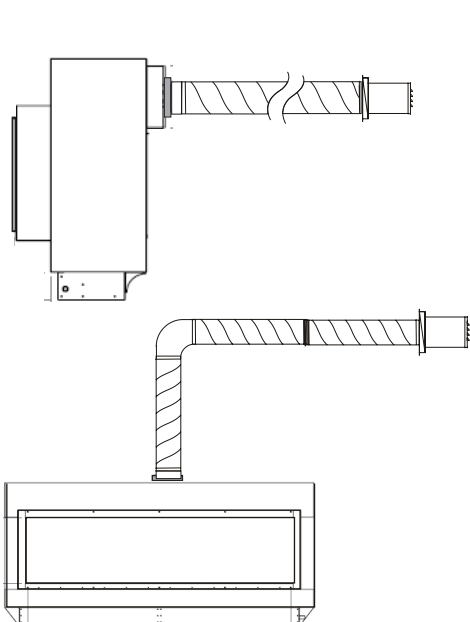

**Figure 12.** Straight Horizontal, Top or Rear Vent, Wall mounted power vent.

Min. 7 feet of pipe between fireplace and power vent

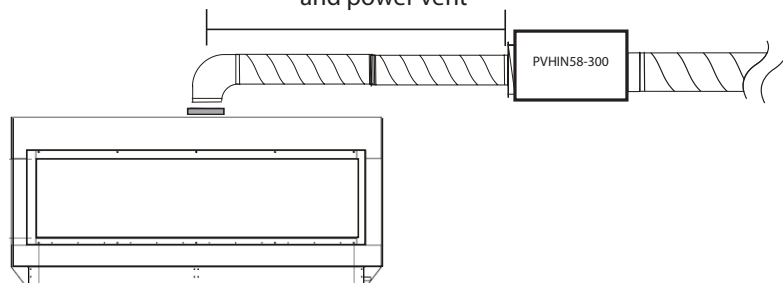

**Figure 12a.** PVHIN58-300 Power Vent

**Note:** PVHIN58-300 cannot be installed closer than 7" feet to fireplace.

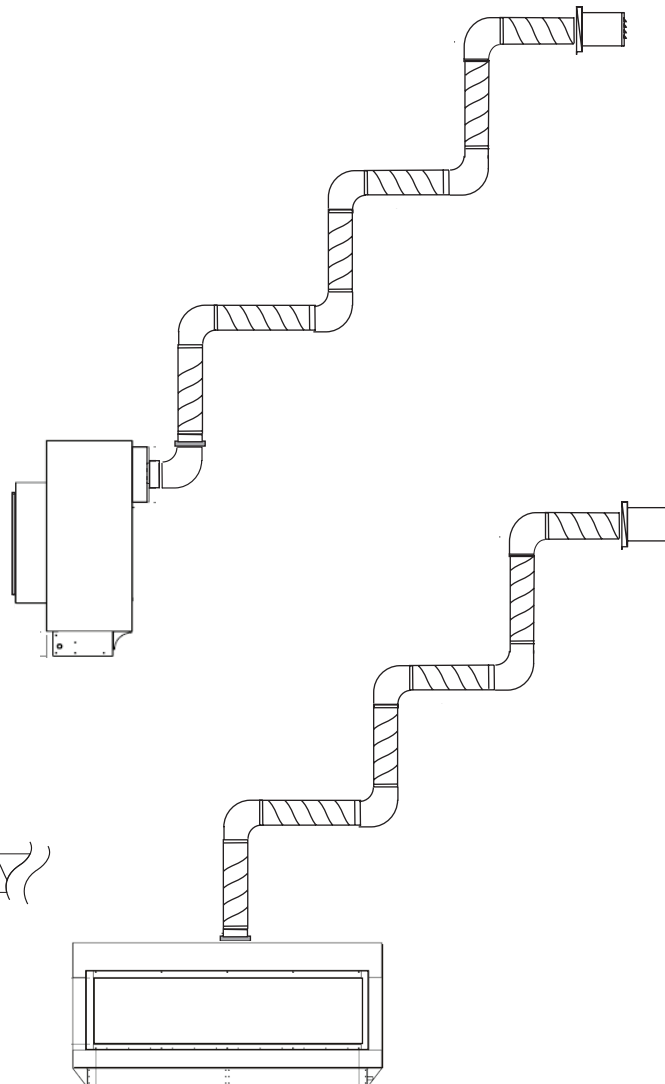

**Figure 12b.** Multi-Elbow, Top or Rear Vent, Wall mounted power vent.





# Installation

## Section 3-3-1: Installing Wall Mounted Power Vent PVHEX58-300 and Flush Louvered Wall Mounted Power Vent PVHFL58-300

Note: See Power Vent manual for installation instructions.

Note: See Appendix A for clearance to exterior structures.

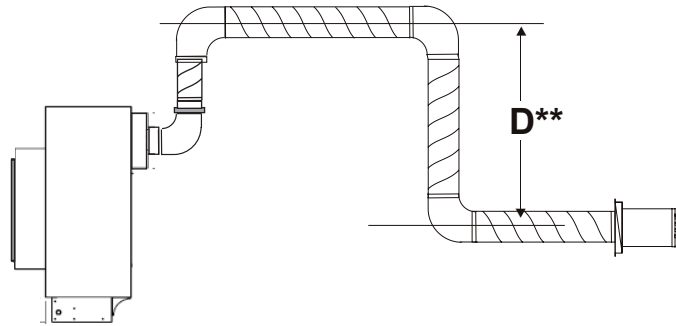
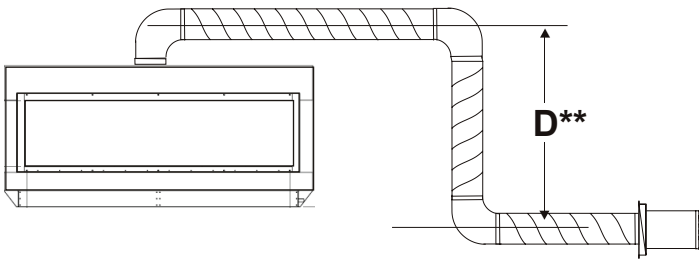

**Figure 12c.** Multi-Elbow with downward vent run, Top or Rear Vent, Wall mounted power vent.

**Note:** Images are shown without screens for clarity purposes. However, your fireplace should not be operated without proper installation of screens.

# Installation



## Section 3-4: Venting components

The following components and associated Montigo part numbers are for installation of a roof or wall mounted Power Vent. **Only use Montigo Vent Components.** Use of non-Montigo parts will VOID the warranty and may impede operation of the fireplace.

<b>A - Termination</b>	PVHEX58-300 Wall Mount 5"/8" PVHFL58-300 Flush Wall Mount 5"/8" PVVEX58-300 Roof Mount 5"/8"
<b>C - Flex Sections</b>	PFL1 (12" f/f Section) PFL2 (24" f/f Section) PFL3 (36" f/f Section) PFL4 (48" f/f Section) PFL6 (72" f/f Section)
<b>D - Rigid Sections</b>	PXT - 10 (10" f/f Section) PXT - 20 (20" f/f Section) PEXT - 1 (12" f/m Section) PEXT - 2 (24" f/m Section) PEXT - 3 (36" f/m Section) PEXT - 4 (48" f/m Section) PEXT - 6 (72" f/m Section)
<b>E - Elbows</b>	PEL-90MM (m/m 90° Elbow) PEL-90FF ( f/f 90° Elbow) PEL-90FM ( f/m 90° Elbow) PEL-45FM ( f/m 45° Elbow)
<b>F - Support Ring &amp; Plate</b>	PSPXT-8
<b>G - Firestop</b>	FS-8
<b>H - Heat Shield</b>	RHS101

## Connection and installation of the vent components should adhere to the following guidelines:

- Use any combination of rigid and flex pipe as required and in any orientation (Male connectors can face in any direction).
- Flex sections may be stretched up to 50% of their total length (e.g. a 24" section maybe stretched to 36").
- Ensure the pipe ends male to female slide in a minimum of 1 1/2" of overlap.
- Connect all vent sections using a minimum of three sheet metal screws on the outer pipe flue.
- Ensure all horizontal runs are supported with a minimum of 3 supports per 10' of venting.
- When hanging/ supporting venting, ensure that 1" clearance is maintained on sides and bottom of vent runs and 2" above horizontal vent runs to any combustible material.
- Rigid pipe may be cut less than half way from the **female end only**.
- Ensure when cutting sections of rigid pipe to maintain integrity of internal supports.
- Place the springs, supplied with the pipe kit, between the outer and inner pipes to keep the pipes separate and avoid any possible hot spots.
- Montigo recommends the use of a flex section for the final pipe connected directly to the fireplace offering greater flexibility of installation and absorption of movement.
- Firestops must be installed as required by National & local codes.
- Montigo recommends that all exterior corners and joints be sealed with exterior caulking. However, we encourage you to consult your Building Envelope Engineer or Waterproofing Consultant for further recommendations.

**IMPORTANT:**  
Please Refer to your Building Envelope Engineer or Waterproofing Consultant for a review of ALL penetrations through exterior walls or the roof.



# Installation

## Section 3-5: Heat Shields

### Installing a Wall Mounted RHS101 Heat shield

The RHS101 Heat shield **must be used if vent pipe passes through a wall or ceiling within 6' of the unit.**

To install the RHS101, Slide the Inner Section over the vent pipe that will connect to the fireplace. Then fasten the vent pipe to the back of the fireplace with a minimum of three sheet metal screws. From the outside slide the RHS101 outer section on. To complete the installation fasten the Heat Shield Outer Section & inner section to the structure. See **Figure 14.**

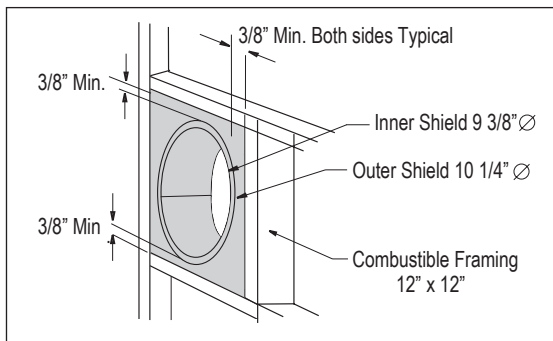

**Figure 14.** RHS101 Installation. (Install by sliding over vent pipe where it passes through the combustible construction).

# Installation



## Section 4: Wiring

### Installing the Fireplace Control Box

Install the Fireplace Control Box in an accessible location. The location should be where maintenance, adjustments and service may be made easily.

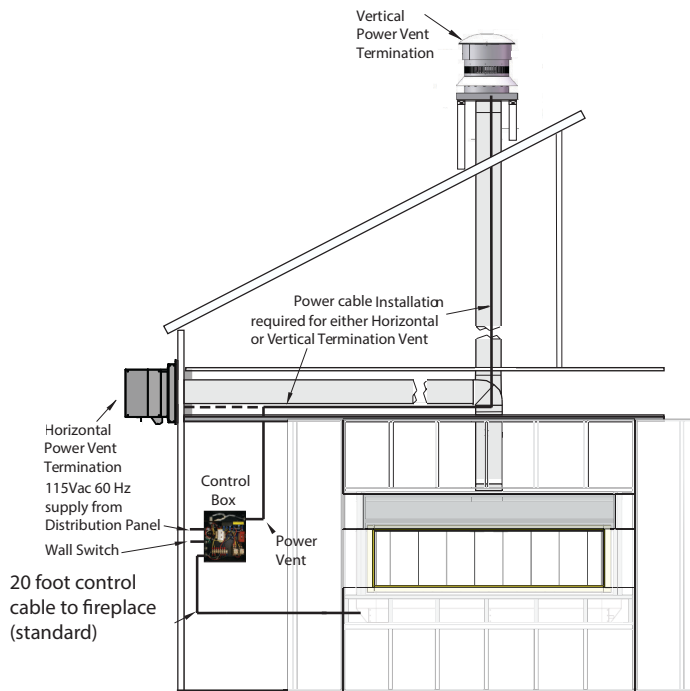

**Figure 15.** R320\* / R420\* Series Control Box / Power Vent Wire Routing Diagram

## CAUTION

Ensure the wires are properly isolated from metal parts or control system will be damaged.



# Installation

## Installation of Electrical Supply

The **R320 / R420** is supplied with an external electrical control panel pre-wired by the factory. The control box is connected to the fireplace with a 20 foot long control cable that will communicate with the fireplace. The control panel should be located where it can be accessed when the fireplace has been finished in.

The power cord from the power vent module plugs into the side of this panel. The 20 foot low voltage wire is attached and connected to this panel as well. Connect a single pole On/Off switch (Black and White) to these two wires at a location of your choice, (See *Installing the Remote Switch*).

Montigo supplies 20' of low voltage wire to the electrical control panel. Connect the two wire harnesses to a standard single pole ON/OFF switch to the location of your choice. You may extend these wires up to 100' in length with a wire of equal quality.

**Installations in Canada** must be electrically grounded in accordance with **CSA C22.1** Canadian Electrical Code Part 1 and/or Local Codes.

**Installations in the USA** must be electrically grounded in accordance with local codes or, in the absence of local codes, with the National Electrical Code, **ANSI/NFPA 70**.

Optional remote control available through your Montigo Dealer.

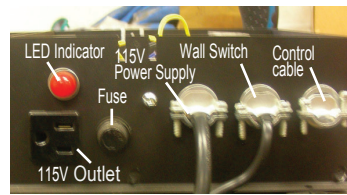

Left-side View



Right-side View

Figure 15b. R320 / R420 Control Module

## Installing the Wall Switch

The **R320 / R420** may be connected to a wall switch. The system operates on a 24V AC. **DO NOT** connect this circuit to an external power source.



Figure 15c. (Wall Switch Wire connection)

**NOTE:** Ensure that you maintain a 1" clearance around the box.

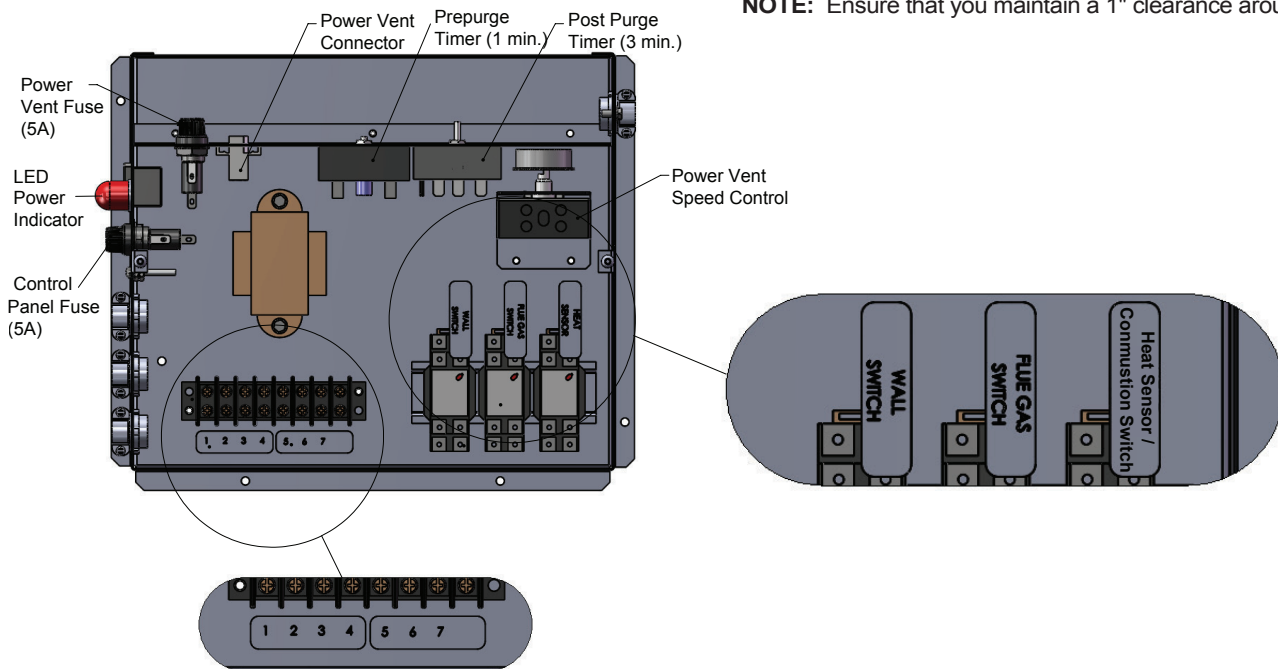
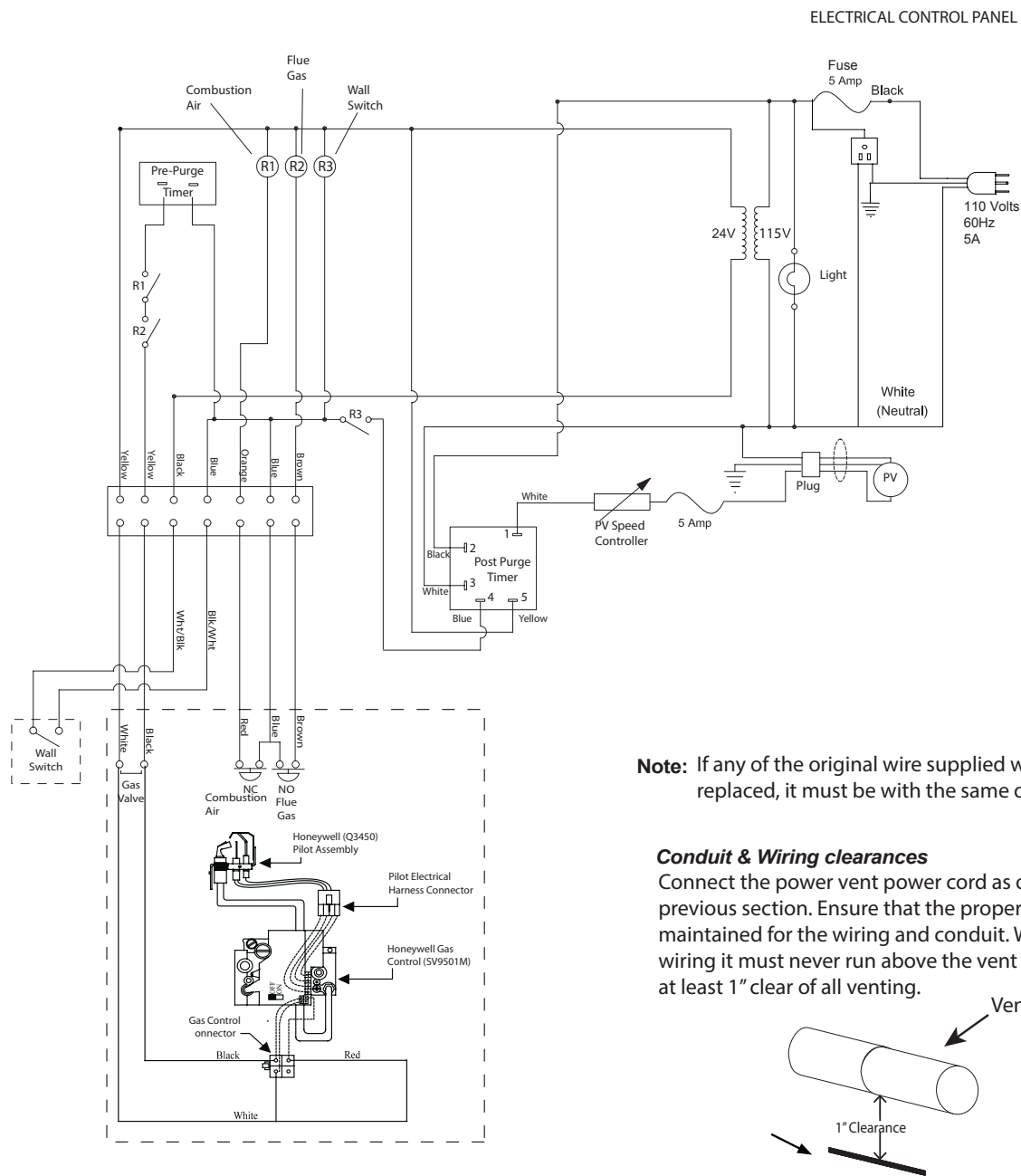

Figure 15a. (Control Panel Overview)



# Installation



**Note:** If any of the original wire supplied with the appliance is replaced, it must be with the same or its equivalent.

### Conduit & Wiring clearances

Connect the power vent power cord as outlined in the previous section. Ensure that the proper clearances are maintained for the wiring and conduit. When installing the wiring it must never run above the vent run and it must be at least 1" clear of all venting.

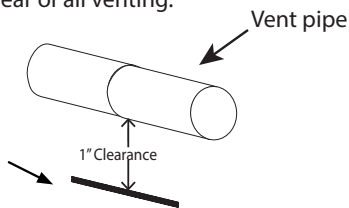

Figure 16. R320\* / R420\* Wiring Diagram



# Installation

## Section 5: Installing the gas line

### Fuel Type

Verify that your fireplace is compatible with your available gas type. Natural Gas or Propane shown by "N" or "L" in your model number on rating plate.

### Gas Pressure

Optimum appliance performance requires proper input pressures. Gas line sizing requirements will be determined in ANSI Z221.3 National Fuel Gas Code in the USA and CAN/CGAB149 in Canada.

#### Pressure requirements (during operation):

Pressure Requirements		
Gas Pressure	Natural Gas	Propane
Minimum Inlet Pressure	5.5" W.C.	11" W.C.
Manifold Pressure	3.5" W.C.	10" W.C.

The manifold outlet pressure is set from the factory to the appropriate pressure but should be verified.

To check pressures, control valves have a provision to remove a 1/8" N.P.T. plug to be fitted with a hose barb.

Montigo requires a service shut off valve be located in an accessible location to isolate the gas supply.

Only install gas shut-off valves approved for use by the state, province, or other governing body in which the fireplace is being installed.

### GAS CONNECTION

See **Figure 16** below for location of gas line access.

Flexible gas connectors must not exceed 3 feet in length, unless allowable within local regulations.

Connect incoming gas line to the 1/2" Male NPT gas inlet.

Purge all air out of gas line before connecting port.

Check appliance connection, valve and valve train under normal operating pressure with a commercially available leak check solution.

**DO NOT USE A FLAME OF ANY KIND TO TEST FOR LEAKS.**

Located next to the Gas Inlet is the Combustion Air Switch Sensor Line.

Do NOT obstruct or alter the Combustion Air Switch Sensor Line.

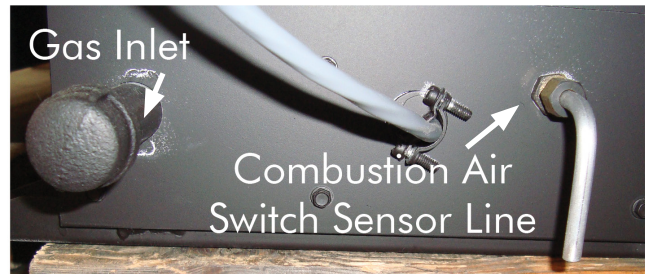

**Figure 17a.** Identifying the Gas Inlet and Combustion Air Switch Sensor Line

 **DANGER**

After gas line is connected, each appliance connection, valve and valve train MUST be checked while under normal operating pressure with either a Liquid Solution, or Leak Detection Device, to locate any source of leak. Tighten any areas where bubbling appears or a leak is detected until bubbling stops completely or leak is no longer detected. DO NOT use a flame of any kind to test for leaks. A fire or explosion will occur, causing serious injury, property damage or death.

**NOTICE**

When pressure testing the fireplace, Gas line, and input system follow the appropriate local codes for your area. DO NOT connect the fireplace to pressures in excess of 1/2lb. This will damage the gas control valve.

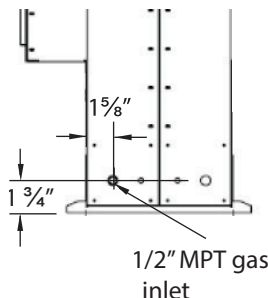

**Figure 17.** Gas Inlet Supply location.

# Installation



## Section 6: Testing the system

### 6-1: Testing the system before gas connection

**Note:** No gas is needed to test the system

The **R320\*/R420\*** Control and Power Vent System can be safely tested prior to finish framing the Fireplace. This test can be done quickly and efficiently to ensure all systems function according to the design specifications.

The fireplace should be installed on the rough-in frame, **Figure 3** with the Power Vent Module and the Vent run connected.

- The control panel is supplied with a power cord plug in.
- Plug it into an extension cord or any other 110 Volt power supply.
- If the red LED is illuminated (beside the fuse) you have power to the panel.
- If no LED, check fuse and replace with equally rated fuse.
- Turn the wall switch to the on position.
- Wall switch and combustion air LED light up immediately.

Approximately 30 seconds later when the power vent reaches factory set speed, the flue gas switch LED will light up approximately 1 minute after flue gas LED is lit and the gas valve will turn on. You can hear a clicking sound and the Hot Surface Ignitor will glow red. This confirms the control system operation. **NOTE:** If the flue gas LED does not light up after 1 minute, slowly increase the power vent speed until the LED turns on. Speed controller located inside the control box, see figure 15a



**Figure 18. LED Indicators**

### 6-2: Testing the system with gas connection

*(Highly recommended)*

The **R320\*/R420\*** Control and Power Vent System can be safely tested prior to finish framing the Fireplace. This test can be done quickly and efficiently to ensure all systems function according to the design specifications.

The fireplace should be installed on the rough-in frame, **Figure 3** with the Power Vent Module and the Vent run connected.

- Turn gas supply valve on
- The control panel is supplied with a power cord plug in.
- Plug it into a extension cord or any other 110 Volt power supply.
- If the red LED is illuminated (beside the fuse) you have power to the panel.
- If no LED, check fuse and replace with equally rated fuse.
- Turn the wall switch to the on position.
- Once the fireplace is running normally, confirm manifold pressure and supply pressure.



# Installation

## Section 7: Finishing the fireplace

As shown in **Figure 19**; Install the supplied Non-combustible cement board to overlap the new Horizontal & Vertical 2 x 4's, See **Figure 5**. Place the Non-combustible wall board above the fireplace throat, allowing 1/8" clearance from the rim above the fireplace opening. Pre-drill the board with 1/8" drill and secure to framing with Nails, use flat heat sheet metal screws to fasten the board to the metal header. **Please note**, images are shown without screens for clarity purposes. However, your fireplace should not be operated without proper installation of screens.

(Non-Combustible cement board **R320\***: 52 1/2" x 15 1/2" **R420\***: 62 1/2" x 15 1/2")

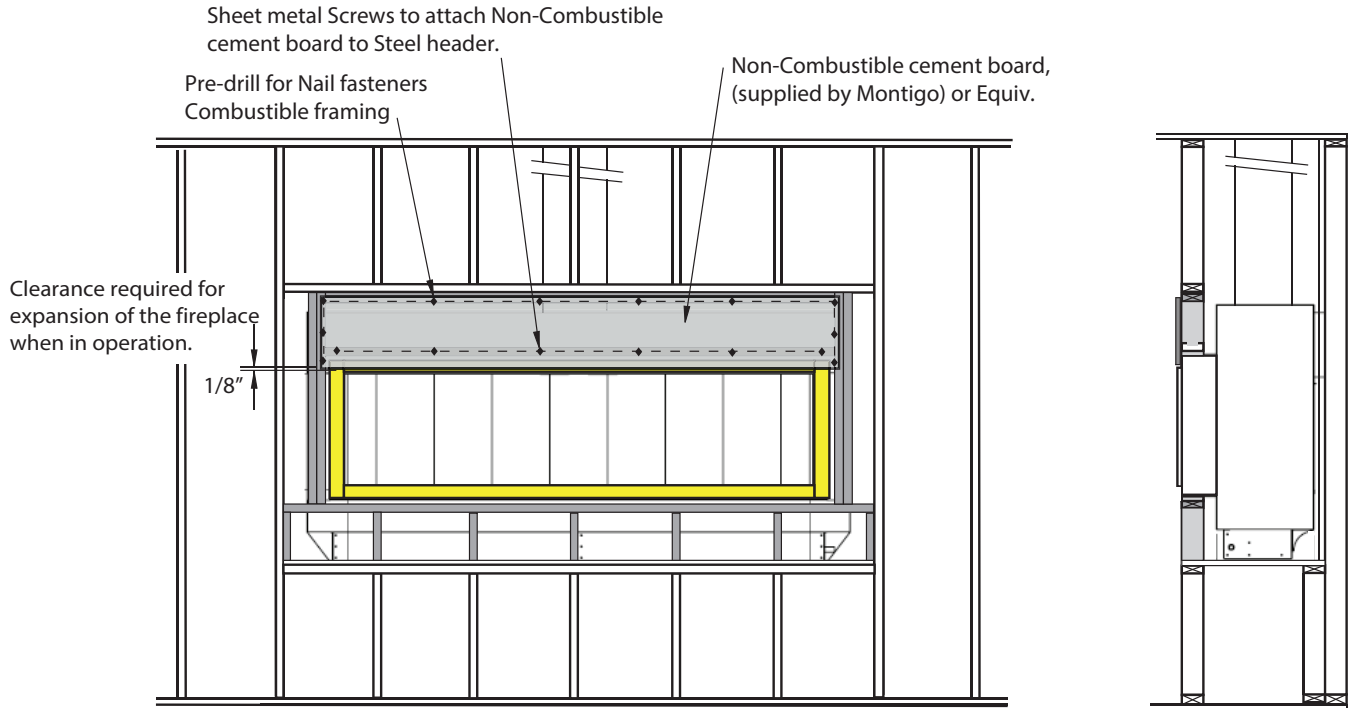

**Figure 19.** Non-combustible Board over the Fireplace, (supplied by Montigo).

Cut standard Gyproc / Drywall board to complete the installation of the surround. Fit the edge of the board to the rim around the fireplace opening. Fasten the board in place using standard drywall screws.

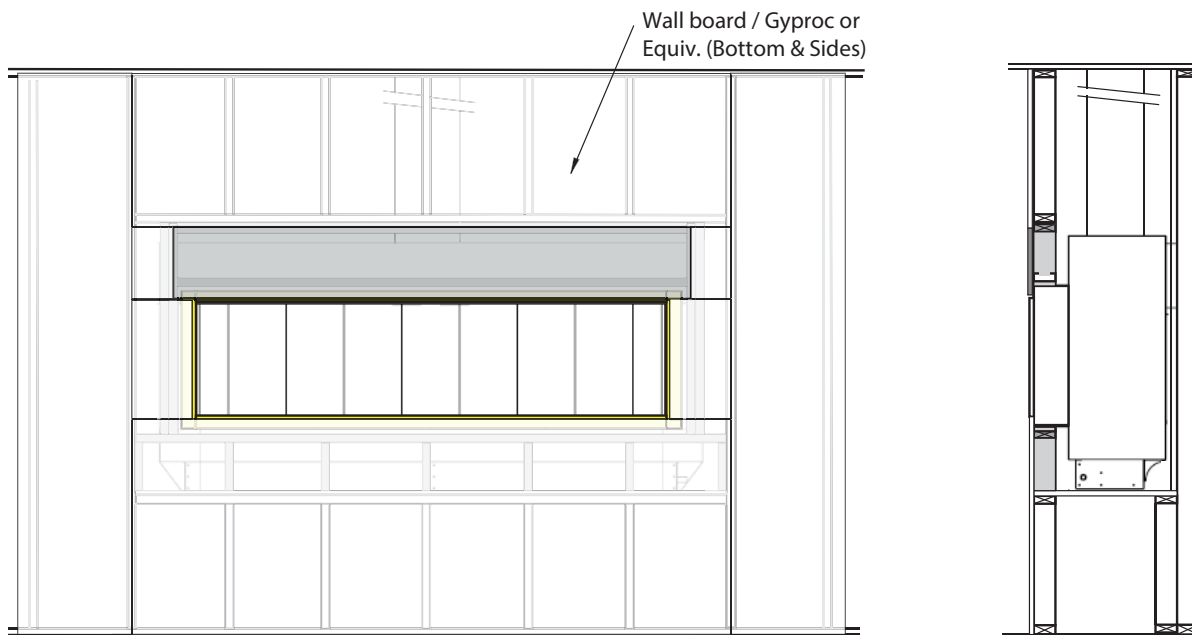

**Figure 19a.** Fireplace installation (Cut the remainder of Gyproc / Wall board to complete the fireplace surround).

# Installation



## Finishing Around the Fireplace

Non-combustible mantels and mouldings may be safely installed over the top and on the front of the fireplace provided that they do not project beyond shaded area shown in **Figure 20**.

The face of the fireplace may be painted to match the room decor, provided you use a heat-resistant paint. Decorative facing must not extend past the fireplace opening at all, because it will interfere with the access to retainers for removal of glass door.

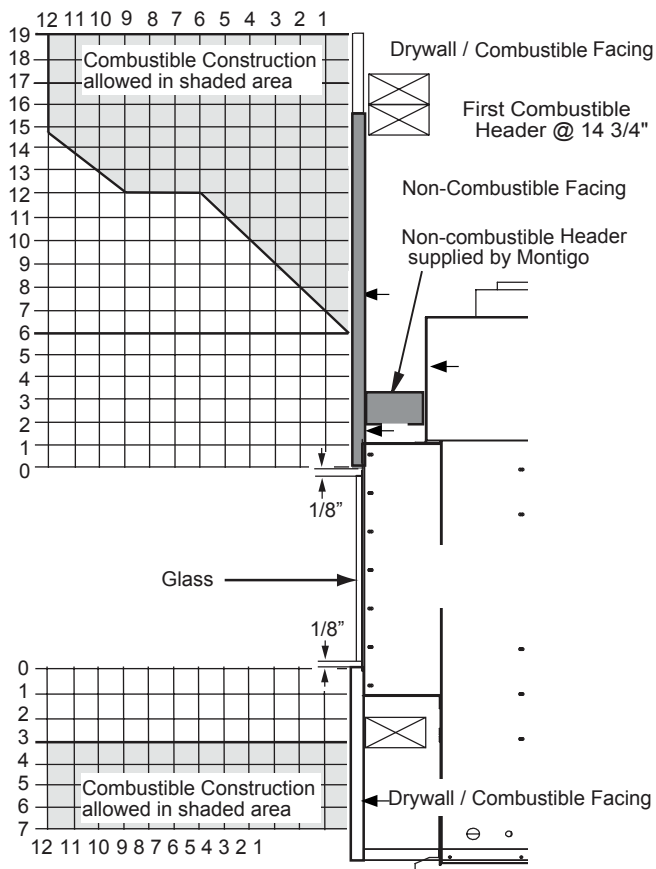

## Mantels & Surrounds

**NOTE:** National Canadian Gas Association mantel test requirements are for fire hazard prevention to combustible materials.

New technology, to meet consumer and government demands for the wise use of energy, has prompted us to manufacture many models of fireplaces which are hot, fuel and energy efficient.

Please be aware; temperatures over the mantel will rise above normal room temperature and walls above fireplace may be hot to touch.

We recommend careful consideration be given to the effects of elevated mantel temperatures which may be in excess of product design, for example: candles, plastic or pictures. This can cause melting, deformation, discoloration or premature failure of T.V. and radio components.

Side wall clearances are 6". Combustible surrounds may be installed with 6" clearance to the side of the fireplace as shown in **Figure 21**.

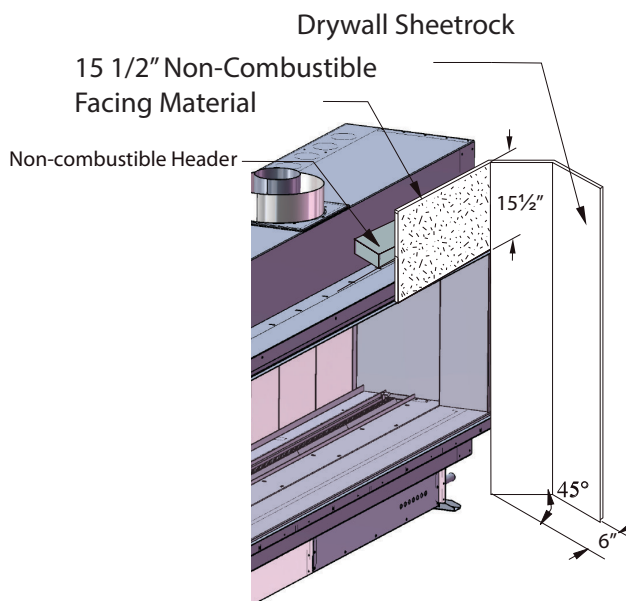

**Figure 21.** Combustible surrounds.

**Figure 20.** Combustible mantels and facings. (Not to scale)

**Note:** Images are shown without screens for clarity purposes. However, your fireplace should not be operated without proper installation of screens.





# Installation

## Section 8: Removing & Installing Screen and Window

### Removing the Screen:

Follow the steps below to remove, or install the R320\* / R420\* fireplace screen and door.

Before beginning any screen or glass removal, make sure that the unit has not been in operation and that it is at room temperature.

#### Step 1: Prepare to Lift out Screen Assembly

Grip either end of the screen assembly and pull towards yourself. The screen assembly is held to the unit by both friction and magnets.

#### Step 2: Lift out the Retaining Tabs and Screen.

The Retaining Tabs are quite long and in most cases, this task would be better performed by two people.

Once the Retaining Tabs have come away from the Fireplace, lift the screen away and store in a safe place. The Screen is very fragile and can be easily torn, dented or deformed. Refer to Figure 21a below.

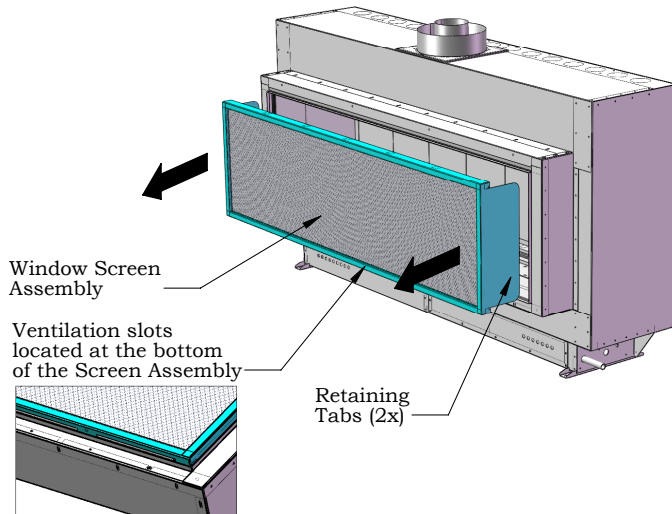

Figure 21a. Screen Removal.

### Removing the Window:

Follow the steps to remove, or install the R320\*/R420\* fireplace window.



**Step 1: Use Glass Lifting Tools to Remove Window**  
Use the Glass Lifting Tools that are included with your fireplace (see image above). Attach one to each end of the window pane. Make certain that they are firmly attached and secure.

#### Step 2: Lift out Window from Grooves

The window is removed by first lifting upward on the glass and then by pulling the bottom out from the groove in which it was located (see image below).



Figure 21b. Window Removal (using glass lifting tools).

Once the bottom of the window is clear of the fireplace, lower the window down from the upper groove in which it was located.

Lift the window clear of the fireplace and store it in a safe place.

**Note:** Never re-use the window if it has been broken, scratched or damaged in any way. The window is made of tempered glass, and although tempered glass is very durable - nicks, scratches or chips can seriously impact the window's strength.

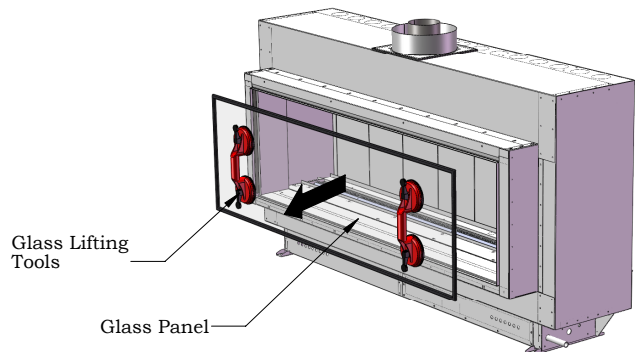

Figure 21c. Window Removal.

### Reinstalling the door:

Follow the four previous steps to re-install the R-Series fireplace window.

# Installation



## Section 9: Installing the Firestones

The **R320\*** / **R420\*** is supplied with glass firestones. To install the firestones remove the trim and door as shown in the previous section. Follow these instructions to ensure all parts are removed or replaced as required. Once the trim and glass door is removed, place the firestones randomly around the burners as shown in **Figures 22 and 22a**.

**Note: DO NOT cover the burner with firestones or any other media.**

### Optional River Rocks

The R320\*/R420\* has the option of installing the cultured rocks which mimic real stone. These may be spaced at random, or in a visual pattern of your preference. See the Montigo web site for photographs and ideas.

[www.montigo.com](http://www.montigo.com)



**Figure 22.** Completed glass Firestone installation.



**Figure 22a.** Operating Propane gas fireplace with designer glass Firestones surrounding burner tray.

**NOTICE**

Do not operate this fireplace without the glass door or with a broken glass door.

### Firestones

**R320\*** requires three 3lbs bags for a total of 9lbs of firestones

**R420\*** requires four 3lbs bags for a total of 12lbs of firestones



Operation

# Operation

**FOR YOUR SAFETY - READ BEFORE LIGHTING :**

 **DANGER**



**HOT GLASS WILL CAUSE BURNS.**

**DO NOT TOUCH GLASS UNTIL COOLED.**

**NEVER ALLOW CHILDREN TO TOUCH GLASS.**

A barrier designed to reduce the risk of burns from the hot viewing glass is provided with this appliance and shall be installed for the protection of children and other at-risk individuals.

**WARNING** If the information in these instructions are not followed exactly, a fire or explosion may result causing property damage, personal injury or death.

**WARNING / CAUTION: Hot while in operation. Do not touch. Severe burns may result. Keep children, clothing, furniture, gasoline and other liquids having flammable vapors away.**

**See installation and operating instructions accompanying this appliance.**

- A. This appliance has a pilot which is lit automatically. Do not attempt to light the pilot by hand.
- B. BEFORE LIGHTING smell all around the appliance area for gas. Be sure to smell next to the floor because some gas is heavier than air and will settle on the floor.
  - What To Do If You Smell Gas:
    - Do not try to light the appliance.
    - Do not touch any electrical switch. Do not use any phone in your building.
    - Immediately call your gas supplier from a neighbour's phone. Follow the gas suppliers instructions.
- C. If you cannot reach your gas supplier, call the Fire Department.
- C. Use only your hand to push in or turn the gas control knob. Never use tools. If the knob will not push in or turn by hand, don't try to repair it. Call a qualified service technician. Force or attempt to repair may result in a fire or explosion.
- D. Do not use this appliance if any part has been under water. Immediately call a qualified service technician to inspect the appliance and to replace any part of the control system, and any gas control which has been under water.

**LIGHTING INSTRUCTIONS:**

1. STOP! Read the safety information above on this label.
2. Turn the fireplace "OFF" using the wall switch or remote control.
3. Wait 5 minutes to clear out any gas. If you smell gas, STOP! Follow "B" in the safety information above on this label. If you don't smell gas, go to the next step.
4. Turn the fireplace "ON" using the wall switch or remote control.
5. The wall switch LED and heat sensor/combustion air LED will light up.
6. Once the predetermined airflow is established in the firebox, the flue gas switch LED will light up after 30 seconds.
7. After approximately 1 minute the hot surface igniter will start to glow. The pilot will light up, followed by the main burner. The fireplace will then start up.

**NOTE:** If the igniter does not glow, even after 3 minutes have passed, follow the instructions "To Turn Off Gas To Appliance" and call your service technician or Montigo dealer.

This unit is equipped with advanced safety controls including pre and post purge timers. The fireplace will not turn on until all of the safety conditions are met. The fans in the fireplace may operate for an extended period of time even after the wall switch is turned off.

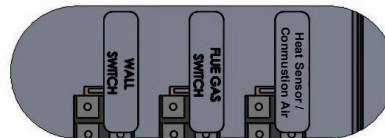

Control box LED lights

**TO TURN OFF GAS TO APPLIANCE:**

1. Turn the fireplace off using the wall switch or remote control.
2. Turn off all electrical power to the appliance.
3. Locate the gas shut off valve for the appliance and turn off.

P/N LB1174-112614



# Maintenance



## Section 10: Cleaning and Maintenance

### General

- **Have the fireplace and installation inspected yearly.** The inspection must include, but is not limited to, the following:
  - A visual check of the entire vent system and termination.
  - An inspection of the door gaskets to ensure a proper seal.
  - An inspection of the burner, vent run, and primary air openings.
  - An inspection of the gas valve, gas components, and pilot flame. For your convenience a 1/8" manifold pressure tap is supplied on the gas valve for a test gauge connection.
- For **Natural Gas** this appliance requires a minimum inlet pressure of 5.5" W.C. and a manifold pressure of 3.5" W.C.
- For **Propane Gas** this appliance requires a minimum inlet pressure of 11" W.C. and a manifold pressure of 10" W.C.
- Always keep the fireplace area clear and free of combustible materials, as well as gasoline and other flammable vapors and liquids.
- Do not use this appliance if any part has been under water. Immediately call a qualified service technician to inspect the appliance and to replace any part of the control system and any gas control which has been under water.

### Cleaning

When the fireplace is first activated, there may be some smoking and a visible film may be left on the glass. This is a normal condition, and is the result of burning of protective coatings on new metal.

- Glass must be cleaned periodically to remove any film (which is a normal by-product of combustion) which may be visible. Film can easily be removed by removing the door, as shown on Page 29. Handle the door carefully, and clean it with non-abrasive, non-ammonia based glass cleaners. One of the most effective products is Kel-Kem.
- Silicone seals on inner door during initial firing will "offgas", leaving a visual deposit of a white substance on combustion chamber walls. This can easily be removed using normal household products.
- Use a vacuum cleaner or whisk broom to keep the control compartment, burner, and firebox free from dust and lint.

### Procedure for Checking Calibration of Flue Gas Switch

- 1). Disconnect power vent harness from the plug in the control box.
- 2). Turn wall switch 'ON'.
- 3). Monitor flue gas switch LED for 2 minutes and ensure LED does not come on or the glow plug will not light during this period.
- 4). Reconnect power vent harness to plug in the control box.

## NOTICE

Do not use ammonia based or abrasive cleaners on the glass, they will permanently etch the surface. Use an approved gas fireplace glass cleaner such as Kel-Kem or White off.

### Gas Control Valve

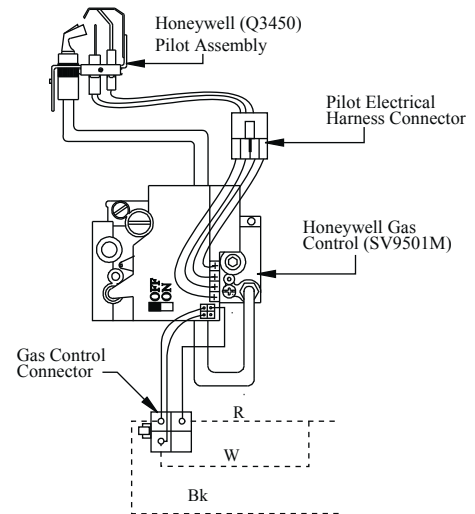

**Figure 23.** Gas valve.

# Appendix

## Appendix A: Power Vent Locations

### PVVEX58-300 Vertical Power Vent Detail

For installation instructions on this termination see instruction guide for the PVVEX58-300.

# Not Acceptable

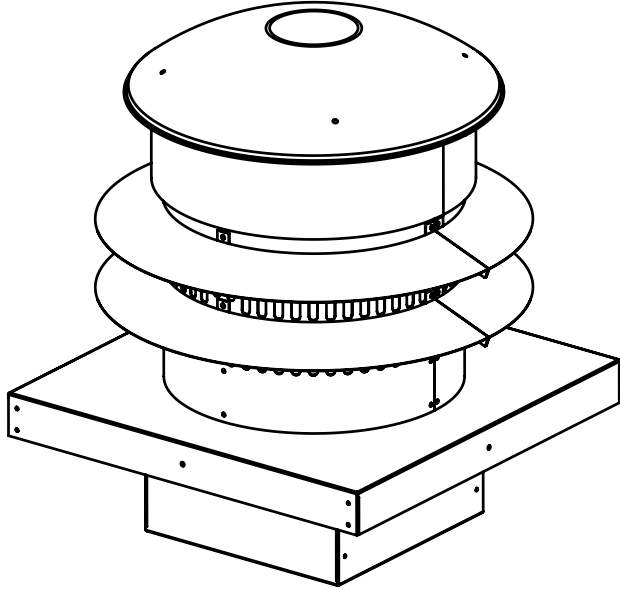

Figure 24. PVVEX58-300

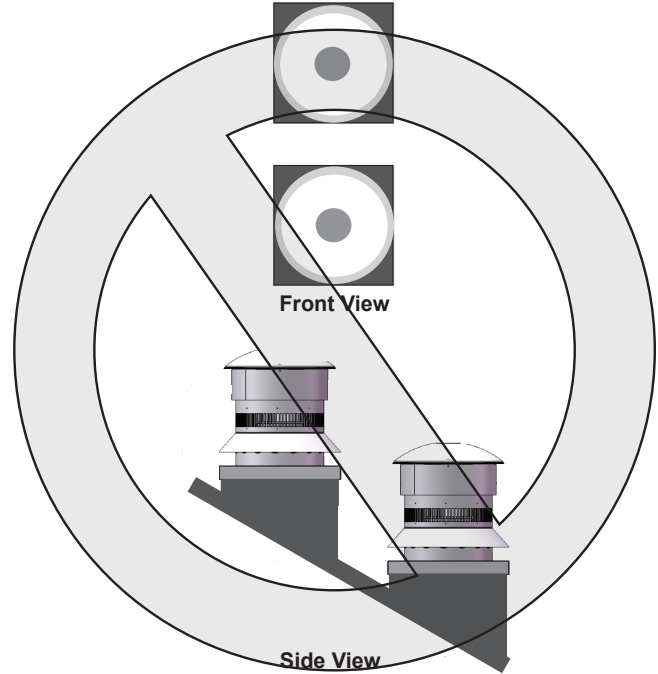

Figure 24b. PVVEX58-300 restrictions

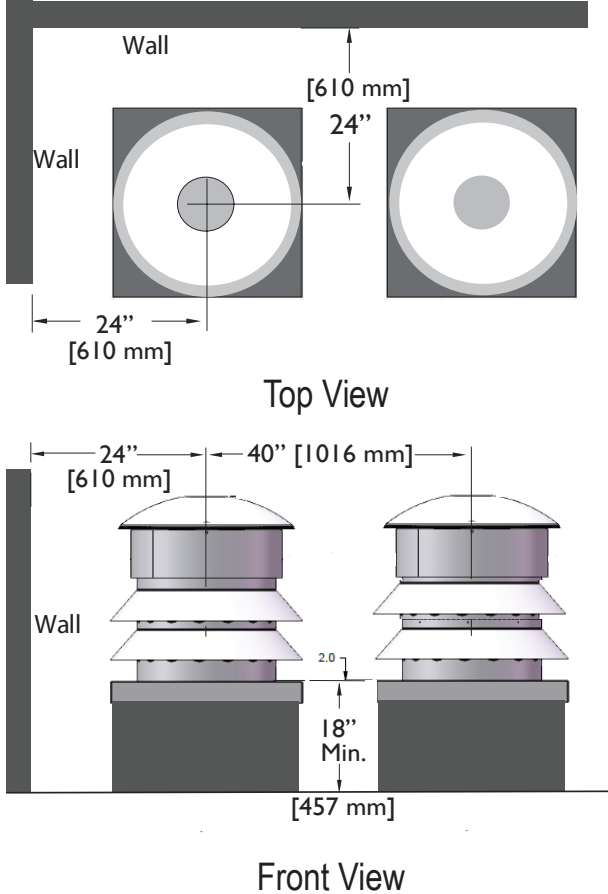

Figure 24a. PVVEX58-300 clearances

# Maintenance



## Replacement Parts

Honeywell HSI		
	R320	R420
NG Gas Valve	RGC1004	
LP Gas Valve	RGC1003	
NG Pilot Assembly	RPA003	
LP Pilot Assembly	RPA004	
Power Vent Control Box	RESCB2	
Outer Glass	RGL1073	RGL1074
Replacement Screen	RSCR320	RSCR420
Fuse, AGC-5Amp	EC1122	

# Appendix

## Appendix A: Power Vent Locations PVVEX58-300 Power Vent Locations

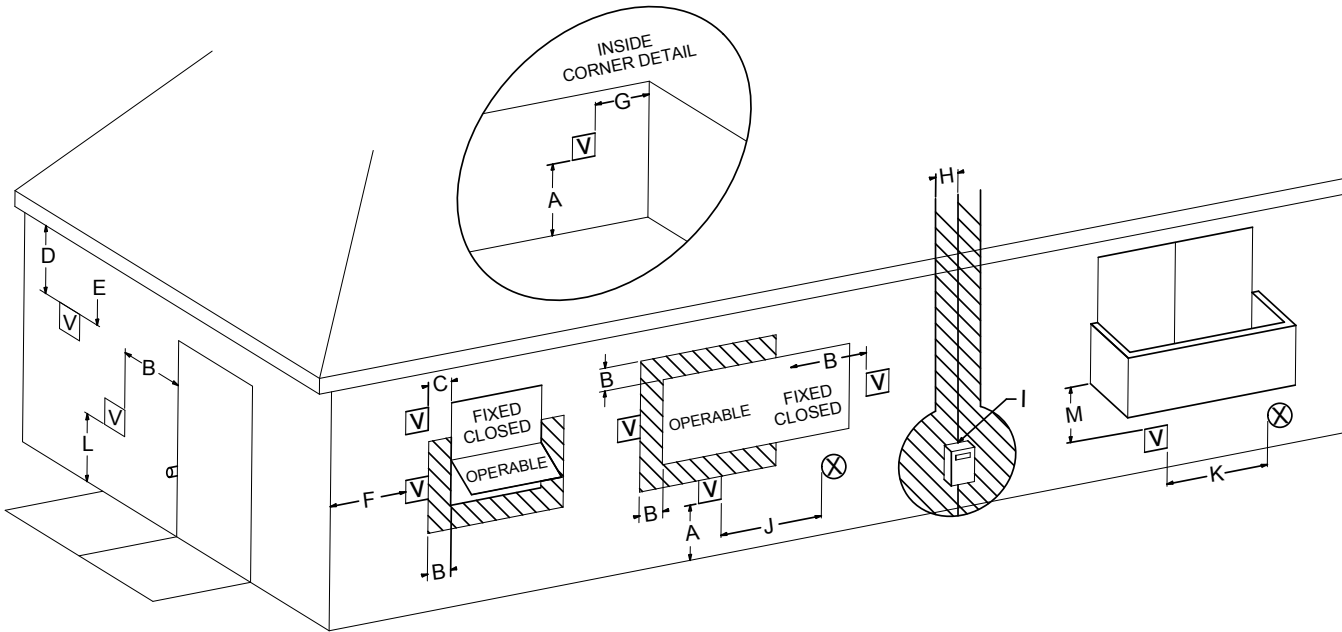

**V** VENTER TERMINAL      **X** AIR SUPPLY INLET       AREA WHERE TERMINAL IS NOT PERMITTED

	Canadian Installations <sup>1</sup>	US Installations <sup>2</sup>
A= Clearance above grade, veranda, porch, deck, or balcony	12 in (30 cm)	12 in (30 cm)
B= Clearance to window or door that may be opened	6 in (15 cm) for appliances ≤ 10,000 Btuh (3 kW), 12 in (30 cm) for appliances > 10,000 Btuh (3 kW) and ≤ 100,000 Btuh (30 kW), 36 in (91 cm) for appliances > 100,000 Btuh (30 kW)	6 in (15 cm) for appliances ≤ 10,000 Btuh (3 kW), 9 in (23 cm) for appliances > 10,000 Btuh (3 kW) and < 50,000 Btuh (15 kW), 12 in (30 cm) for appliances ≥ 50,000 Btuh (15 kW)
C= Clearance to permanently closed window	<b>B</b>	<b>B</b>
D= Vertical clearance to ventilated soffit located above the terminal within a horizontal distance of 2 feet (61 cm) from the center line of the terminal	N/A	N/A
E= Clearance to unventilated soffit	*	*
F= Clearance to outside corner	*	*
G= Clearance to inside corner	*	*
H= Clearance to each side of center line extended above meter/regulator assembly	3 ft (91 cm) within a height 15 ft. (4.5 m) above the meter/regulator assembly	*
I= Clearance to service regulator vent outlet	3 ft (91 cm)	*

	Canadian Installations <sup>1</sup>	US Installations <sup>2</sup>
J= Clearance to nonmechanical air supply inlet to building or the combustion air inlet to any other appliance	6 in (15 cm) for appliances ≤ 10,000 Btuh (3 kW), 12 in (30 cm) for appliances > 10,000 Btuh (3 kW) and ≤ 100,000 Btuh (30 kW), 36 in (91 cm) for appliances > 100,000 Btuh (30 kW)	6 in (15 cm) for appliances ≤ 10,000 Btuh (3 kW), 9 in (23 cm) for appliances > 10,000 Btuh (3 kW) and ≤ 50,000 Btuh (15 kW), 12 in (30 cm) for appliances > 50,000 Btuh (15 kW)
K= Clearance to a mechanical air supply inlet	6 ft (1.83 m)	3 ft (91 cm) above if within 10 ft (3 m) horizontally
L= Clearance above paved sidewalk or paved driveway located on public property	7 ft (2.13 m) †	*
M= Clearance under veranda porch deck, or balcony	12 in (30 cm) ‡	*

1 In accordance with the current CSA B149.1, Natural Gas and Propane Installation Code  
 2 In accordance with the current ANSI Z223.1/NFPA 54, National Fuel Gas Code  
 † A vent shall not terminate directly above a sidewalk or paved driveway that is located between two single family dwellings and serves both dwellings.  
 ‡ Permitted only if veranda, porch, deck, or balcony is fully open on a minimum of two sides beneath the floor.  
 \* For clearances not specified in ANSI Z223.1/NFPA or CSA B149.1, one of the following shall be indicated  
 a) A minimum clearance value determined by testing in accordance with section 2.23.5, or;  
 b) A reference to the following footnote:  
 "Clearance in accordance with local installation codes and the requirements of the gas supplier"

**Figure 24c. PVVEX58-300 Power Vent Locations**

# Appendix

## PVHEX58-300 Horizontal Power Vent Detail

For installation instructions on this termination see instruction guide for the PVHEX58-300.

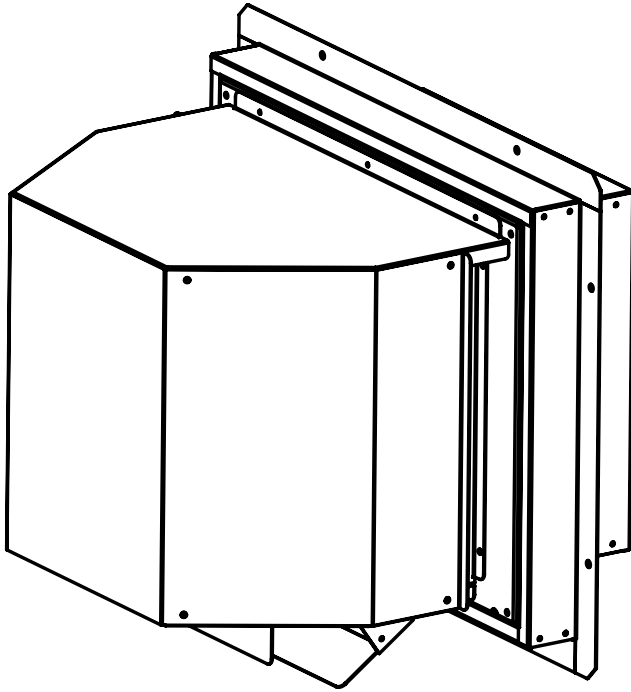
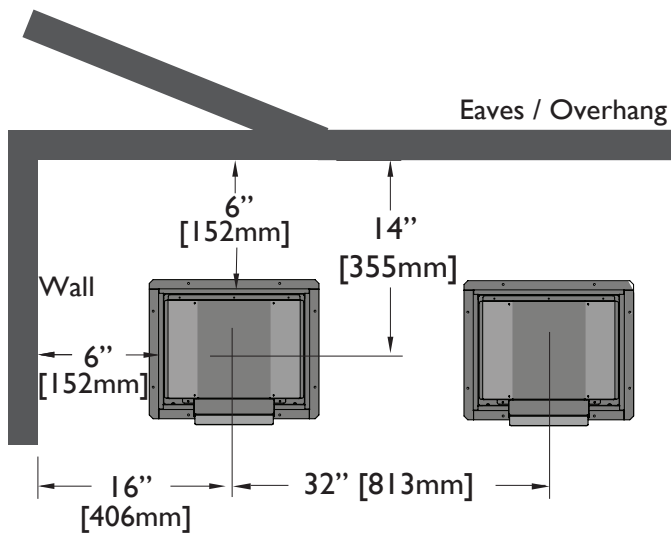

Figure 25. PVHEX58-300



### Side View

Figure 25a. PVHEX58-300 Termination Clearances

# Appendix

## PVHEX58-300 Power Vent Locations

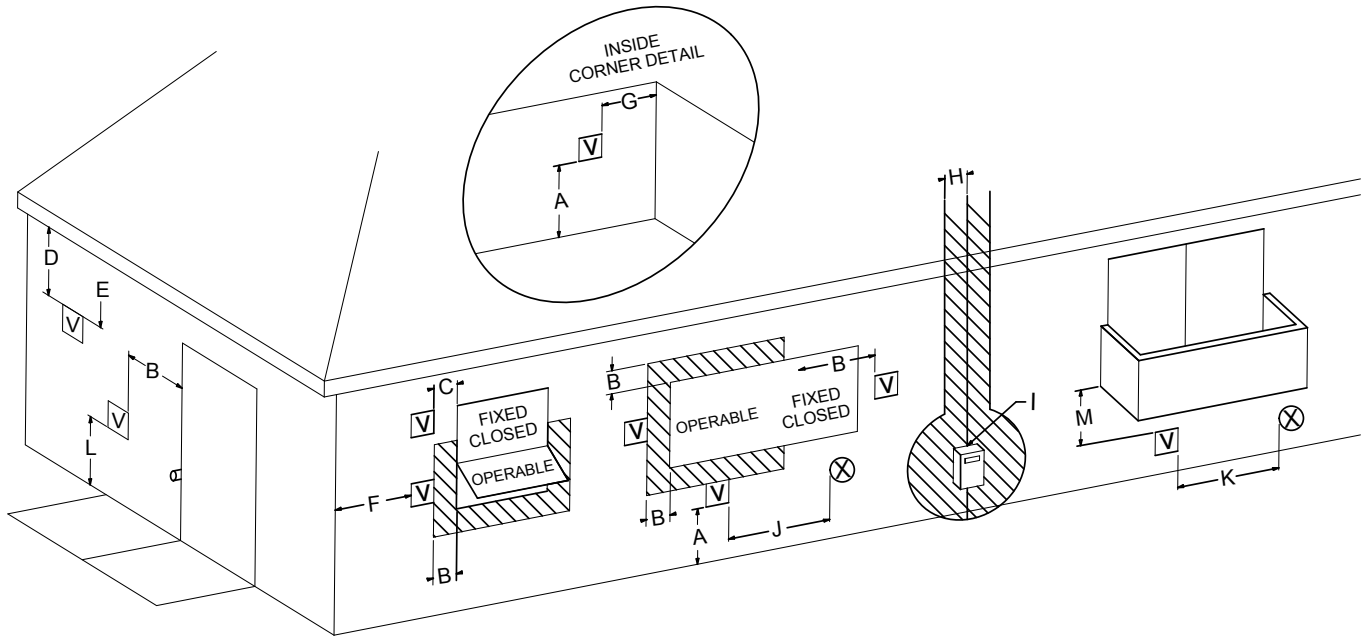

 VENTER TERMINAL       AIR SUPPLY INLET       AREA WHERE TERMINAL IS NOT PERMITTED

	Canadian Installations <sup>1</sup>	US Installations <sup>2</sup>
A= Clearance above grade, veranda, porch, deck, or balcony	12 in (30 cm)	12 in (30 cm)
B= Clearance to window or door that may be opened	6 in (15 cm) for appliances ≤ 10,000 Btuh (3 kW), 12 in (30 cm) for appliances > 10,000 Btuh (3 kW) and ≤ 100,000 Btuh (30 kW), 36 in (91 cm) for appliances > 100,000 Btuh (30 kW)	6 in (15 cm) for appliances ≤ 10,000 Btuh (3 kW), 9 in (23 cm) for appliances > 10,000 Btuh (3 kW) and < 50,000 Btuh (15 kW), 12 in (30 cm) for appliances ≥ 50,000 Btuh (15 kW)
C= Clearance to permanently closed window	<b>B</b>	<b>B</b>
D= Vertical clearance to ventilated soffit located above the terminal within a horizontal distance of 2 feet (61 cm) from the center line of the terminal	6 in (15 cm)	6 in (15 cm)
E= Clearance to unventilated soffit	6 in (15 cm)	6 in (15 cm)
F= Clearance to outside corner	6 in (15 cm)	6 in (15 cm)
G= Clearance to inside corner	6 in (15 cm)	6 in (15 cm)
H= Clearance to each side of center line extended above meter/regulator assembly	3 ft (91 cm) within a height 15 ft. (4.5 m) above the meter/regulator assembly	*
I= Clearance to service regulator vent outlet	3 ft (91 cm)	*

	Canadian Installations <sup>1</sup>	US Installations <sup>2</sup>
J= Clearance to nonmechanical air supply inlet to building or the combustion air inlet to any other appliance	6 in (15 cm) for appliances ≤ 10,000 Btuh (3 kW), 12 in (30 cm) for appliances > 10,000 Btuh (3 kW) and ≤ 100,000 Btuh (30 kW), 36 in (91 cm) for appliances > 100,000 Btuh (30 kW)	6 in (15 cm) for appliances ≤ 10,000 Btuh (3 kW), 9 in (23 cm) for appliances > 10,000 Btuh (3 kW) and ≤ 50,000 Btuh (15 kW), 12 in (30 cm) for appliances > 50,000 Btuh (15 kW)
K= Clearance to a mechanical air supply inlet	6 ft (1.83 m)	3 ft (91 cm) above if within 10 ft (3 m) horizontally
L= Clearance above paved sidewalk or paved driveway located on public property	7 ft (2.13 m) †	*
M= Clearance under veranda porch, deck, or balcony	12 in (30 cm) ‡	*

1 In accordance with the current CSA B149.1, Natural Gas and Propane Installation Code  
 2 In accordance with the current ANSI Z223.1/NFPA 54, National Fuel Gas Code  
 † A vent shall not terminate directly above a sidewalk or paved driveway that is located between two single family dwellings and serves both dwellings.  
 ‡ Permitted only if veranda, porch, deck, or balcony is fully open on a minimum of two sides beneath the floor.  
 \* For clearances not specified in ANSI Z223.1/NFPA or CSA B149.1, one of the following shall be indicated  
 a) A minimum clearance value determined by testing in accordance with section 2.23.5, or;  
 b) A reference to the following footnote:  
 "Clearance in accordance with local installation codes and the requirements of the gas supplier"

**Figure 25b.** PVHEX58-300 Power Vent Locations

# Appendix

## PVHFL58-300 Horizontal Power Vent Detail

For installation instructions on this termination see instruction guide for the PVHFL58-300.

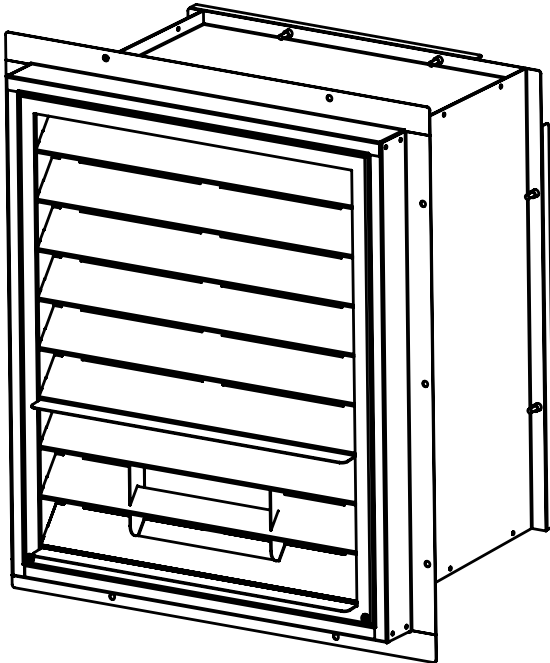

Figure 26. PVHFL58-300

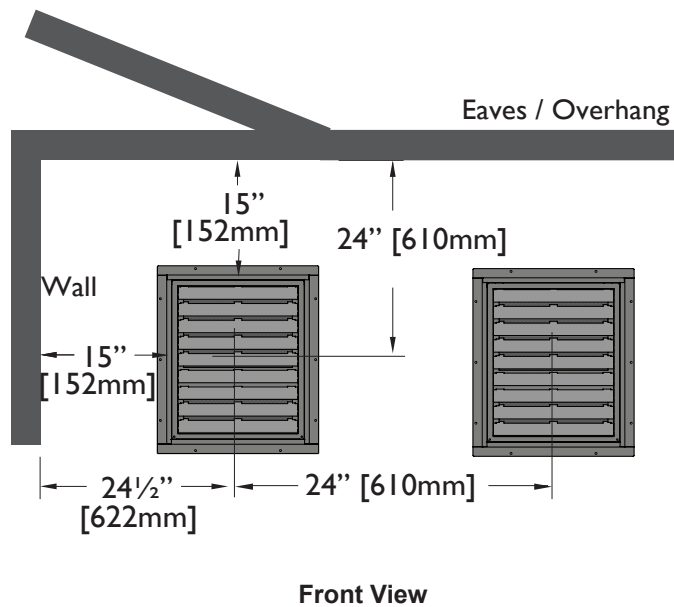
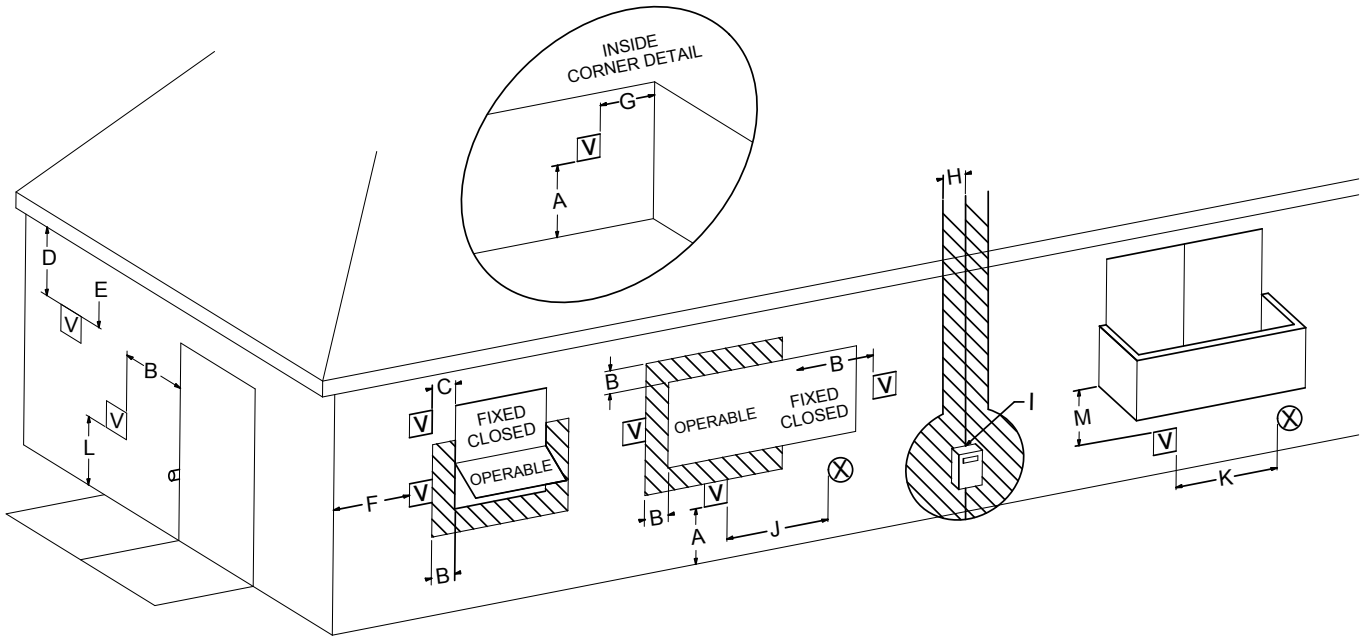

Figure 26a. PVHFL58-300 Termination Clearances

# Appendix

## PVHFL58-300 Power Vent Locations



V VENTER TERMINAL     
 X AIR SUPPLY INLET     
   AREA WHERE TERMINAL IS NOT PERMITTED

	Canadian Installations <sup>1</sup>	US Installations <sup>2</sup>
A= Clearance above grade, veranda, porch, deck, or balcony	12 in (30 cm)	12 in (30 cm)
B= Clearance to window or door that may be opened	6 in (15 cm) for appliances ≤ 10,000 Btuh (3 kW), 12 in (30 cm) for appliances > 10,000 Btuh (3 kW) and ≤ 100,000 Btuh (30 kW), 36 in (91 cm) for appliances > 100,000 Btuh (30 kW)	6 in (15 cm) for appliances ≤ 10,000 Btuh (3 kW), 9 in (23 cm) for appliances > 10,000 Btuh (3 kW) and < 50,000 Btuh (15 kW), 12 in (30 cm) for appliances ≥ 50,000 Btuh (15 kW)
C= Clearance to permanently closed window	<b>B</b>	<b>B</b>
D= Vertical clearance to ventilated soffit located above the terminal within a horizontal distance of 2 feet (61 cm) from the center line of the terminal	15 in (38 cm)	15 in (38 cm)
E= Clearance to unventilated soffit	15 in (38 cm)	15 in (38 cm)
F= Clearance to outside corner	6 in (15 cm)	6 in (15 cm)
G= Clearance to inside corner	15 in (38 cm)	15 in (38 cm)
H= Clearance to each side of center line extended above meter/regulator assembly	3 ft (91 cm) within a height 15 ft. (4.5 m) above the meter/regulator assembly	*
I= Clearance to service regulator vent outlet	3 ft (91 cm)	*

	Canadian Installations <sup>1</sup>	US Installations <sup>2</sup>
J= Clearance to nonmechanical air supply inlet to building or the combustion air inlet to any other appliance	6 in (15 cm) for appliances ≤ 10,000 Btuh (3 kW), 12 in (30 cm) for appliances > 10,000 Btuh (3 kW) and ≤ 100,000 Btuh (30 kW), 36 in (91 cm) for appliances > 100,000 Btuh (30 kW)	6 in (15 cm) for appliances ≤ 10,000 Btuh (3 kW), 9 in (23 cm) for appliances > 10,000 Btuh (3 kW) and ≤ 50,000 Btuh (15 kW), 12 in (30 cm) for appliances > 50,000 Btuh (15 kW)
K= Clearance to a mechanical air supply inlet	6 ft (1.83 m)	3 ft (91 cm) above if within 10 ft (3 m) horizontally
L= Clearance above paved sidewalk or paved driveway located on public property	7 ft (2.13 m) †	*
M= Clearance under veranda porch deck, or balcony	12 in (30 cm) ‡	*

<sup>1</sup> In accordance with the current CSA B149.1, Natural Gas and Propane Installation Code  
<sup>2</sup> In accordance with the current ANSI Z223.1/NFPA 54, National Fuel Gas Code  
 † A vent shall not terminate directly above a sidewalk or paved driveway that is located between two single family dwellings and serves both dwellings.  
 ‡ Permitted only if veranda, porch, deck, or balcony is fully open on a minimum of two sides beneath the floor.  
 \* For clearances not specified in ANSI Z223.1/NFPA or CSA B149.1, one of the following shall be indicated  
 a) A minimum clearance value determined by testing in accordance with section 2.23.5, or;  
 b) A reference to the following footnote:  
 "Clearance in accordance with local installation codes and the requirements of the gas supplier"

**Figure 26b. PVHFL58-300 Power Vent Locations**



## Appendix

### PVHIN58-300 Inline Power Vent with TMHIN58-40 Detail

For installation instructions on this power vent and termination see instruction guide for the PVHIN58-300 with TMHIN58-40.

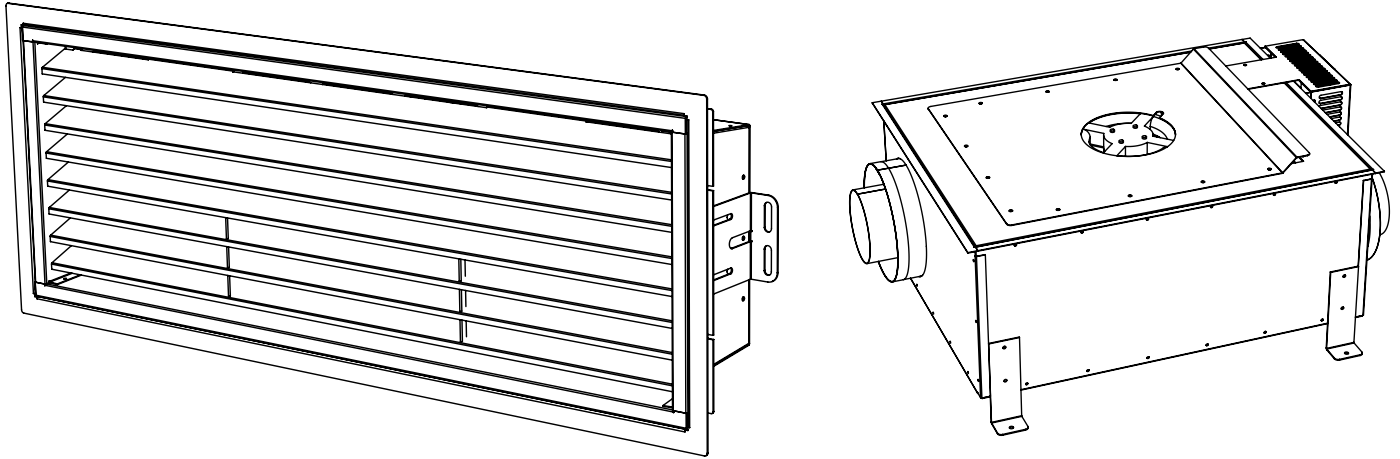

**Figure 27.** PVHIN58-300 Inline power vent with TMHIN58-40 Termination (with vanity ring)

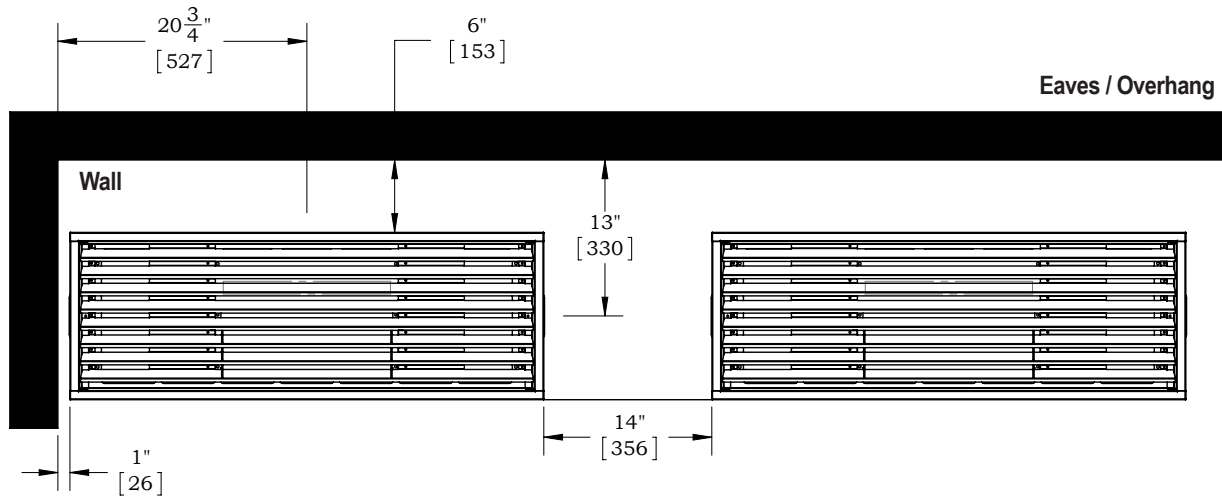
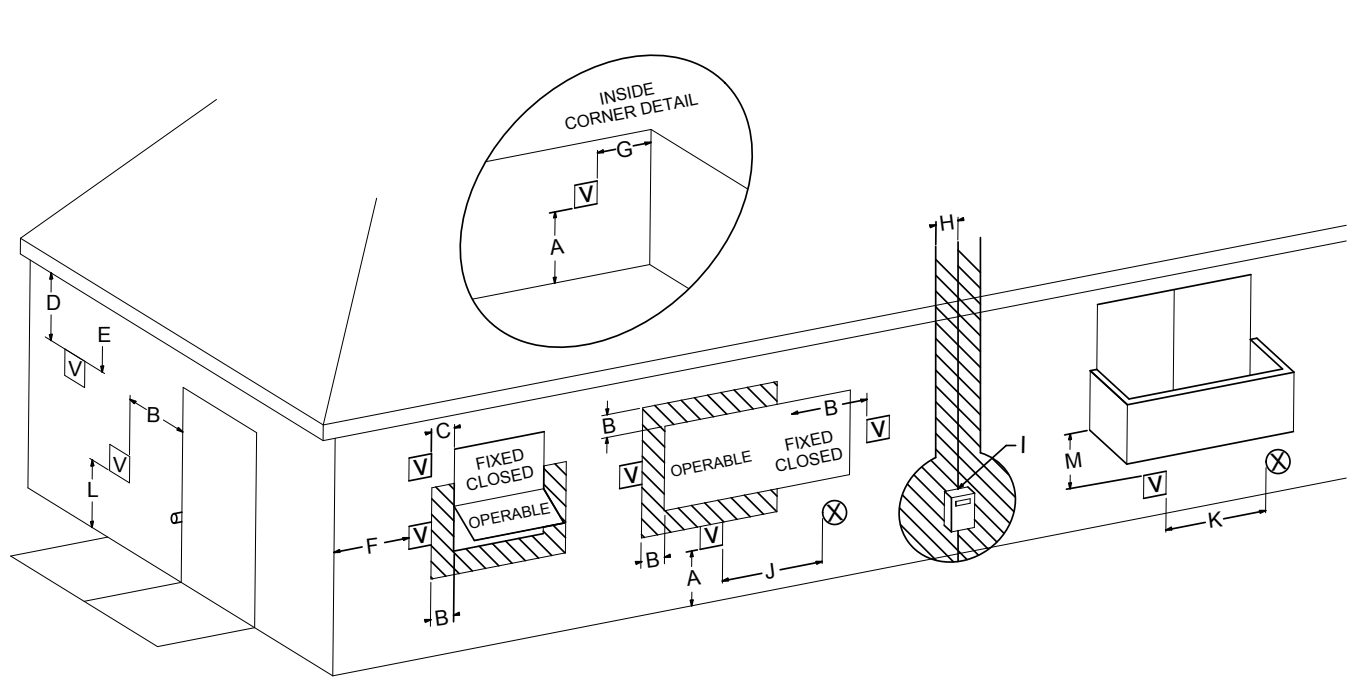

**Figure 27a.** TMHIN58-40 Termination Clearances (without vanity ring)

**Note:** There is enough clearance in the above clearances drawing to allow for a vanity ring to be added on at a later time.

# Appendix

## PVHIN58-300 Inline Power Vent with TMHIN58-40 Termination Locations



V VENTER TERMINAL     
 X AIR SUPPLY INLET     
  AREA WHERE TERMINAL IS NOT PERMITTED

	Canadian Installations <sup>1</sup>	US Installations <sup>2</sup>
A= Clearance above grade, veranda, porch, deck, or balcony	12 in (30 cm)	12 in (30 cm)
B= Clearance to window or door that may be opened	6 in (15 cm) for appliances ≤ 10,000 Btuh (3 kW), 12 in (30 cm) for appliances > 10,000 Btuh (3 kW) and ≤ 100,000 Btuh (30 kW), 36 in (91 cm) for appliances > 100,000 Btuh (30 kW)	6 in (15 cm) for appliances ≤ 10,000 Btuh (3 kW), 9 in (23 cm) for appliances > 10,000 Btuh (3 kW) and < 50,000 Btuh (15 kW), 12 in (30 cm) for appliances ≥ 50,000 Btuh (15 kW)
C= Clearance to permanently closed window	<b>B</b>	<b>B</b>
D= Vertical clearance to ventilated soffit located above the terminal within a horizontal distance of 2 feet (61 cm) from the center line of the terminal	6 in (38 cm)	6 in (38 cm)
E= Clearance to unventilated soffit	6 in (38 cm)	6 in (38 cm)
F= Clearance to outside corner	* (15 cm)	* (15 cm)
G= Clearance to inside corner	0 in (38 cm)	0 in (38 cm)
H= Clearance to each side of center line extended above meter/regulator assembly	3 ft (91 cm) within a height 15 ft. (4.5 m) above the meter/regulator assembly	*
I= Clearance to service regulator vent outlet	3 ft (91 cm)	*

	Canadian Installations <sup>1</sup>	US Installations <sup>2</sup>
J= Clearance to nonmechanical air supply inlet to building or the combustion air inlet to any other appliance	6 in (15 cm) for appliances ≤ 10,000 Btuh (3 kW), 12 in (30 cm) for appliances > 10,000 Btuh (3 kW) and ≤ 100,000 Btuh (30 kW), 36 in (91 cm) for appliances > 100,000 Btuh (30 kW)	6 in (15 cm) for appliances ≤ 10,000 Btuh (3 kW), 9 in (23 cm) for appliances > 10,000 Btuh (3 kW) and ≤ 50,000 Btuh (15 kW), 12 in (30 cm) for appliances > 50,000 Btuh (15 kW)
K= Clearance to a mechanical air supply inlet	6 ft (1.83 m)	3 ft (91 cm) above if within 10 ft (3 m) horizontally
L= Clearance above paved sidewalk or paved driveway located on public property	7 ft (2.13 m) †	*
M= Clearance under veranda porch, deck, or balcony	12 in (30 cm) ‡	*

<sup>1</sup> In accordance with the current CSA B149.1, Natural Gas and Propane Installation Code  
<sup>2</sup> In accordance with the current ANSI Z223.1/NFPA 54, National Fuel Gas Code  
 † A vent shall not terminate directly above a sidewalk or paved driveway that is located between two single family dwellings and serves both dwellings.  
 ‡ Permitted only if veranda, porch, deck, or balcony is fully open on a minimum of two sides beneath the floor.  
 \* For clearances not specified in ANSI Z223.1/NFPA or CSA B149.1, one of the following shall be indicated:  
 a) A minimum clearance value determined by testing in accordance with section 2.23.5, or;  
 b) A reference to the following footnote:  
 "Clearance in accordance with local installation codes and the requirements of the gas supplier"

**Figure 27b.** PVHIN58-300 Inline Power Vent with TMHIN58-40 Termination Locations

## Appendix

### Appendix B: Warranty

#### The Warranty

The Companies warrants the Montigo Gas Appliance to be free from defects in materials and workmanship at the time of manufacture. On the Montigo fireplace, there is a ten-year warranty on the firebox and its components, a five-year warranty on the main burner and pilot burner, and a one-year warranty on the gas control valve, fibre logs and Power Vent Module. The Glass, plated / painted finishes, and refractory lining are exempt from the warranty.

#### Remedy And Exclusions

The coverage of this Warranty is limited to all components of the Gas Appliance manufactured by The Companies.

This Warranty only covers Montigo Gas Appliances installed in the United States or Canada.

If the components of the Gas Appliance covered by this Warranty are found to be defective within the time frame stated (see The Companies right of investigation outlined below). The Companies will, at its option, replace or repair defective components of the Gas Appliance manufactured by The Companies at no charge, and will also pay for reasonable labour costs incurred in replacing or repairing components. If repair or replacement is not commercially practical, The Companies will, at its option, refund the purchase price of the Montigo Gas Appliance.

This Warranty covers only parts and labour as provided above. In no case shall The Companies be responsible for materials, components, or construction which are not manufactured or supplied by The Companies, or for the labour necessary to install, repair or remove such materials, components or construction. All replacement or repair components will be shipped F.O.B. the nearest The Companies factory.

#### Qualifications To The Warranty

The Gas Appliance Warranty outlined above is further subject to the following qualifications:

- (1) The Gas Appliance must be installed in accordance with The Companies installation instructions and local building codes. The Warranty on this Montigo Gas Appliance covers only the component parts manufactured by The Companies. The use of components manufactured by others with this Montigo Gas Appliance could create serious safety hazards, may result in the denial of certification by recognized national safety agencies, and could be in violation of local building codes. This warranty does not cover any damages occurring from the use of any components not manufactured or supplied by The Companies
- (2) The Montigo Gas Appliance must be subjected to normal use. The Gas Appliances are designed to burn gas only. Burning conventional fireplace fuels such as wood, coal or any other solid fuel will cause damage to the Gas Appliance, will produce excessive temperatures and will result in a fire hazard.

#### Limitations On Liability

It is expressly agreed and understood that The Companies sole obligation, and purchaser's exclusive remedy under this Warranty, under any other warranty, expressed or implied, or in contract, tort or otherwise, shall be limited to replacement, repair, or refund, as specified above.

In no event shall The Companies be responsible for any incidental or consequential damages caused by defects in its products, whether such damage occurs or is discovered before or after replacement or repair, and whether or not such damage is caused by The Companies negligence. Some states do not allow the exclusion or limitation of incidental or consequential damages, so the above limitation or exclusion may not apply to you. The duration of any implied warranty with respect to this Montigo Gas Appliance is limited to the duration of the foregoing warranty. Some states do not allow limitation on how long an implied warranty lasts, so the above may not apply to you.

#### Investigation Of Claims Against Warranty

The Companies reserves the right to investigate any and all claims against this Warranty and to decide upon method of settlement.

#### The Companies Are Not Responsible For Work Done Without Written Consent

The Companies shall in no event be responsible for any warranty work done without first obtaining The Companies written consent.

#### Dealers Have No Authority To Alter This Warranty

The Companies employees and dealers have no authority to make any warranties nor to authorize any remedies in addition to or inconsistent with those stated above.

#### How To Register A Claim Against Warranty

In order for any claim under this Warranty to be valid, The Companies must be notified of the claimed defect in writing or by telephone, as soon as reasonably possible after the defect is discovered. Claims against this Warranty in writing should include the date of installation, and a description of the defect.

#### Other Rights

This Warranty gives you specific legal rights, and you may also have other rights which vary from state to state.

**NOTE:** *The Companies* as stated above refer to - Canadian Heating Products Inc. and/or Montigo Del Ray Corp.

*Canadian Heating Products Inc. and/or Montigo DelRay Corp. reserves the right to make changes at any time, without notice, in design, materials, specifications, prices and also to discontinue colors, styles and products.*

# Appendix

## Appendix C: State of Massachusetts

### Amendment

#### (Gas Fireplace / Equipment sold in the State of Massachusetts)

#### 5.08: Modifications to NFPA-54, Chapter 10

(1) Revise NFPA-54 section 10.5.4.2 by adding a second exception as follows:

Existing chimneys shall be permitted to have their use continued when a gas conversion burner is installed, and shall be equipped with a manually reset device that will automatically shut off the gas to the burner in the event of a sustained back-draft.

(2) Revise 10.8.3 by adding the following additional requirements:

(a) For all side wall horizontally vented gas fueled equipment installed in every dwelling, building or structure used in whole or in part for residential purposes, including those owned or operated by the Commonwealth and where the side wall exhaust vent termination is less than seven (7) feet above finished grade in the area of the venting, including but not limited to decks and porches, the following requirements shall be satisfied:

**1. INSTALLATION OF CARBON MONOXIDE DETECTORS.** At the time of installation of the side wall horizontal vented gas fueled equipment, the installing plumber or gas fitter shall observe that a hard wired carbon monoxide detector with an alarm and battery back-up is installed on the floor level where the gas equipment is to be installed. In addition, the installing plumber or gas fitter shall observe that a battery operated or hard wired carbon monoxide detector with an alarm is installed on each additional level of the dwelling, building or structure served by the side wall horizontal vented gas fueled equipment. It shall be the responsibility of the property owner to secure the services of qualified licensed professionals for the installation of hard wired carbon monoxide detectors

a. In the event that the side wall horizontally vented gas fueled equipment is installed in a crawl space or an attic, the hard wired carbon monoxide detector with alarm and battery back-up may be installed on the next adjacent floor level.

b. In the event that the requirements of this subdivision can not be met at the time of completion of installation, the owner shall have a period of thirty (30) days to comply with the above requirements; provided, however, that during said thirty (30) day period, a battery operated carbon monoxide detector with an alarm shall be installed.

**2. APPROVED CARBON MONOXIDE DETECTORS.** Each carbon monoxide detector as required in accordance with the above provisions shall comply with NFPA 720 and be ANSI/UL 2034 listed and IAS certified.

**3. SIGNAGE.** A metal or plastic identification plate shall be permanently mounted to the exterior of the building at a minimum height of eight (8) feet above grade directly in line with the exhaust vent terminal for the horizontally vented gas fueled heating appliance or equipment. The sign shall read, in print size no less than one-half (1/2) inch in size, "GAS VENT DIRECTLY BELOW. KEEP CLEAR OF ALL OBSTRUCTIONS".

**4. INSPECTION.** The state or local gas inspector of the side wall horizontally vented gas fueled equipment shall not approve the installation unless, upon inspection, the inspector observes carbon monoxide detectors and signage installed in accordance with the provisions of 248 CMR 5.08(2)(a)1 through 4.

(b) EXEMPTIONS: The following equipment is exempt from 248 CMR 5.08(2)(a)1 through 4:

1. The equipment listed in Chapter 10 entitled "Equipment Not Required To Be Vented" in the most current edition of NFPA 54 as adopted by the Board; and

2. Product Approved side wall horizontally vented gas fueled equipment installed in a room or structure separate from the dwelling, building or structure used in whole or in part for residential purposes.

(c) **MANUFACTURER REQUIREMENTS - GAS EQUIPMENT VENTING SYSTEM PROVIDED.** When the manufacturer of Product Approved side wall horizontally vented gas equipment provides a venting system design or venting system components with the equipment, the instructions provided by the manufacturer for installation of the equipment and the venting system shall include:

1. Detailed instructions for the installation of the venting system design or the venting system components; and

2. A complete parts list for the venting system design or venting system.

(d) **MANUFACTURER REQUIREMENTS - GAS EQUIPMENT VENTING SYSTEM NOT PROVIDED.** When the manufacturer of a Product Approved side wall horizontally vented gas fueled equipment does not provide the parts for venting the flue gases, but identifies "special venting systems", the following requirements shall be satisfied by the manufacturer:

1. The referenced "special venting system" instructions shall be included with the appliance or equipment installation instructions; and

2. The "special venting systems" shall be Product Approved by the Board, and the instructions for that system shall include a parts list and detailed installation instructions.

(e) A copy of all installation instructions for all Product Approved side wall horizontally vented gas fueled equipment, all venting instructions, all parts lists for venting instructions, and/or all venting design instructions shall remain with the appliance or equipment at the completion of the installation.

(3) After NFPA-54 section 10.10.4.2 add a new section 10.10.4.3 as follows:

When more than four gas appliances are to be vented through a common gas vent or common horizontal vent manifold, a plan of the proposed vent installation shall be submitted to the Inspector and the serving gas supplier for review and approval.

Extraction from: Massachusetts Rules and Regulations

5.00: Amendments To 2002 Edition Of ANSI Z223.1-NFPA-54





# R320 - R420

## Single Sided Gas Fireplace

