



Installation, Start-Up, and Service Instructions

CONTENTS

	Page
SAFETY CONSIDERATIONS	1,2
GENERAL	2
INSTALLATION	2-28
Step 1 — Check Jobsite	2
Step 2 — Check Unit	2
• STORAGE	
• PROTECTION	
• INSPECT UNIT	
Step 3 — Locate Unit	3
Step 4 — Mount the Unit	6
• VERTICAL UNITS	
• HORIZONTAL UNIT	
Step 5 — Check Duct System	6
Step 6 — Install Condensate Drain	7
Step 7 — Pipe Connections	7
• WATER LOOP APPLICATIONS	
• GROUND-WATER APPLICATIONS	
• GROUND-LOOP APPLICATIONS	
• INSTALLATION OF SUPPLY AND RETURN HOSE KIT	
Step 8 — Wire Field Power Supply	10
Step 9 — Wire Field Controls	25
• THERMOSTAT CONNECTIONS	
• SAFETY DEVICES AND C BOARD CONTROLLER	
• CONSIDERATIONS	
Operate ECM Interface Board	27
PRE-START-UP	28
System Checkout	28
START-UP	29-31
Operating Limits	29
Scroll Compressor Rotation	29
Unit Start-Up Cooling Mode	29
Unit Start-Up Heating Mode	29
Flow Regulation	30
Flushing	30
Antifreeze	30
Cooling Tower/Boiler Systems	30
Ground Coupled, Closed Loop and Plateframe Heat Exchanger Well Systems	31
OPERATION	31-32
Cooling Mode	31
Heating Mode	31
Power Up Mode	31
Units with Aquazone Complete C Control	31
Units with Aquazone Deluxe D Control	31
Units with Hot Gas Reheat Option	31
Sequence of Operation - On/Off Control	31
COMPLETE C AND DELUXE D BOARD SYSTEM TEST	32
Retry Mode	32
LED Fault Indication	32
Complete C Board Default Settings	32
SERVICE	32-34
Filters	32
Water Coil	32
Condensate Drain Pans	32
Refrigerant System	32
Compressor	32
Fan Motors	33
Condensate Drain Cleaning	33
Air Coil Cleaning	33
Condenser Cleaning	33
Checking System Charge	33
Refrigerant Charging	34
Air Coil Fan Motor Removal	34
TROUBLESHOOTING	34-37
Control Sensors	34
Thermistor	34
Thermostatic Expansion Valves	34
Moisture Check	36
50PSH,PSV START-UP CHECKLIST	CL-1, CL-2

IMPORTANT: Read the entire instruction manual before starting installation.

SAFETY CONSIDERATIONS

Installation and servicing of air-conditioning equipment can be hazardous due to system pressure and electrical components. Only trained and qualified service personnel should install, repair, or service air-conditioning equipment.

Untrained personnel can perform basic maintenance functions such as cleaning coils and filters and replacing filters. All other operations should be performed by trained service personnel. When working on air-conditioning equipment, observe precautions in the literature, tags and labels attached to the unit, and other safety precautions that may apply.

Improper installation, adjustment, alteration, service, maintenance, or use can cause explosion, fire, electrical shock or other conditions which may cause personal injury or property damage. Consult a qualified installer, service agency, or a local distributor or branch for information or assistance. The qualified installer or agency must use factory-authorized kits or accessories when modifying this product. Refer to the individual instructions packaged with the kits or accessories when installing.

Follow all safety codes. Wear safety glasses and work gloves. Use quenching cloth for brazing operations. Have fire extinguisher available. Read these instructions thoroughly and follow all warnings or cautions attached to the unit. Consult local building codes and the National Electrical Code (NEC) for special installation requirements.

Understand the signal words — DANGER, WARNING, and CAUTION. DANGER identifies the most serious hazards which will result in severe personal injury or death.

WARNING signifies hazards that could result in personal injury or death. CAUTION is used to identify unsafe practices, which would result in minor personal injury or product and property damage.

Recognize safety information. This is the safety-alert symbol (⚠). When this symbol is displayed on the unit and in instructions or manuals, be alert to the potential for personal injury.

⚠ WARNING

Electrical shock can cause personal injury or death. Before installing or servicing system, always turn off main power to system. There may be more than one disconnect switch. Turn off accessory heater power if applicable.

GENERAL

This installation and start-up instructions literature is for Aqazone™ single-stage water source heat pump systems.

Water source heat pumps (WSHPs) are single-package horizontally and vertically mounted units with electronic controls designed for year-round cooling and heating.

IMPORTANT: The installation of water source heat pump units and all associated components, parts, and accessories which make up the installation shall be in accordance with the regulations of ALL authorities having jurisdiction and MUST conform to all applicable codes. It is the responsibility of the installing contractor to determine and comply with ALL applicable codes and regulations.

INSTALLATION

Step 1 — Check Jobsite — Installation, operation and maintenance instructions are provided with each unit. Before unit start-up, read all manuals and become familiar with the unit and its operation. Thoroughly check out the system before operation. Complete the inspections and instructions listed below to prepare a unit for installation. See Table 1 for unit physical data.

IMPORTANT: This equipment is designed for indoor installation ONLY. Extreme variations in temperature, humidity and corrosive water or air will adversely affect the unit performance, reliability and service life.

HORIZONTAL UNIT (50PSH) — Horizontal units are designed for indoor installation only. Be sure to allow adequate space around the unit for servicing. See Fig. 1 for overall unit dimensions.

VERTICAL UNITS (50PSV) — Vertical units are designed for indoor installation only. While vertical units are typically installed in a floor-level closet or a small mechanical room, the unit access guidelines for these units are very similar to those described for horizontal units. See Fig. 2 for overall dimensions.

⚠ CAUTION

To avoid equipment damage, do not use these units as a source of heating or cooling during the construction process. The mechanical components and filters used in these units quickly becomes clogged with construction dirt and debris which may cause system damage.

Step 2 — Check Unit — Upon receipt of shipment at the jobsite, carefully check the shipment against the bill of lading. Make sure all units have been received. Inspect the carton or crating of each unit, and inspect each unit for damage.

Ensure the shipping company makes proper notation of any shortages or damage on all copies of the freight bill. Concealed damage not discovered during unloading must be reported to the shipping company within 15 days of receipt of shipment.

NOTE: It is the responsibility of the purchaser to file all necessary claims with the shipping company.

1. Be sure that the location chosen for unit installation provides ambient temperatures maintained above freezing.
2. Be sure the installation location is isolated from sleeping areas, private offices and other acoustically sensitive spaces.
3. Be sure the unit is mounted at a height sufficient to provide an adequate slope of the condensate lines. If an appropriate slope cannot be achieved, a field-supplied condensate pump may be required.
4. On horizontal units, allow adequate room below the unit for condensate drain trap and do not locate the unit above supply piping.
5. Provide sufficient space for duct connection. Do not allow the weight of the ductwork to rest on the unit.
6. Provide adequate clearance for filter replacement and drain pan cleaning. Do not allow piping, conduit, etc. to block filter access.
7. Provide sufficient access to allow maintenance and servicing of the fan and fan motor, compressor and coils. Removal of the entire unit from the closet should not be necessary.
8. Provide an unobstructed path to the unit within the closet or mechanical room. Space should be sufficient to allow return air to freely enter the space.
9. Provide ready access to water valves and fittings, and screwdriver access to unit side panels, discharge collar, and all electrical connections.
10. Where access to side panels is limited, pre-removal of the control box side mounting screws may be necessary for future servicing.

STORAGE — If the equipment is not needed for immediate installation upon its arrival at the job site, it should be left in its shipping carton and stored in a clean, dry area. Units must only be stored or moved in the normal upright position as indicated by the UP arrows on each carton at all times. If unit stacking is required, stack units as follows: vertical units less than 6 tons, no more than two high; horizontal units less than 6 tons, no more than three high. Do not stack units larger than 6 tons.

PROTECTION — Once the units are properly positioned on the jobsite, cover them with either a shipping carton, vinyl film, or an equivalent protective covering. Cap open ends of pipes stored on the jobsite. This precaution is especially important in areas where painting, plastering, or spraying of fireproof material, etc. is not yet complete. Foreign material that accumulates within the units can prevent proper start-up and require costly clean-up operations.

Before installing any of the system components, be sure to examine each pipe, fitting, and valve, and remove any dirt or foreign material found in or on these components.

⚠ CAUTION

DO NOT store or install units in corrosive environments or in locations subject to temperature or humidity extremes (e.g., attics, garages, rooftops, etc.). Corrosive conditions and high temperature or humidity can significantly reduce performance, reliability, and service life. Always move units in an upright position. Tilting units on their sides may cause equipment damage.

INSPECT UNIT — To prepare the unit for installation, complete the procedures listed below:

1. Compare the electrical data on the unit nameplate with ordering and shipping information to verify that the correct unit has been shipped.
2. Do not remove the packaging until the unit is ready for installation.
3. Verify that the unit's refrigerant tubing is free of kinks or dents, and that it does not touch other unit components.
4. Inspect all electrical connections. Be sure connections are clean and tight at their terminations.
5. Loosen compressor bolts until the compressor rides freely on springs. Remove shipping restraints.
6. Remove the shipping bolts from compressor support plate to maximize vibration and sound alternation.

7. Remove any blower support cardboard from inlet of the blower.

Step 3 — Locate Unit — Locate the unit in an indoor area that allows easy removal of the filter and access panels, and has enough room for service personnel to perform maintenance or repair. Provide sufficient room to make fluid, electrical, and duct connection(s). If the unit is located in a confined space such as a closet, provisions must be made for return air to freely enter the space. On horizontal units, allow adequate room below the unit for a condensate drain trap and do not locate the unit above supply piping. These units are not approved for outdoor installation; therefore, they must be installed inside the structure being conditioned. Do not locate units in areas that are subject to freezing.

⚠ CAUTION

Failure to remove shipping brackets from spring-mounted compressors will cause excessive noise and could cause component failure due to added vibration.

Table 1 — Physical Data — 50PSH, PSV 007-070 Units

50PS UNIT SIZE	007	009	012	015	018	024	030	036	042	048	060	070
Compressor Type	Rotary	Rotary	Rotary	Rotary	Rotary	Scroll	Scroll	Scroll	Scroll	Scroll	Scroll	Scroll
Maximum Water Working Pressure (psig/kPa)	400/ 3100	400/ 3100	400/ 3100	400/ 3100	400/ 3100	400/ 3100	400/ 3100	400/ 3100	400/ 3100	400/ 3100	400/ 3100	400/ 3100
STANDARD FAN MOTOR AND BLOWER												
Fan Motor Type/Speeds	PSC/3				Const Torque/3-Speed							
Fan Motor (hp)	1/10	1/10	1/10	1/3	1/3	1/2* / 1/3	1/2	3/4	3/4	3/4	1	1
Blower Wheel Size (Diameter x Width)	4.5 x 4.5	4.5 x 4.5	5.5 x 5.5	5.5 x 4.5	9 x 7	9 x 7	9 x 7	9 x 7	10 x 8	10 x 8	11 x 9	11 x 9
ECM CONST CFM FAN MOTOR												
Fan Motor Type/Speeds	NA	NA	NA	ECM Const CFM/3-Speed								
Fan Motor (hp)	NA	NA	NA	1/3	1/3	1/3	1/2	3/4	3/4	3/4	1	1
WATER CONNECTION SIZE												
FPT	3/4	3/4	3/4	3/4	3/4	3/4	1	1	1	1	1	1
Coaxial Coil Volume (gal)	0.15	0.15	0.31	0.31	0.31	0.48	0.39	0.62	0.62	0.62	0.62	0.85
VERTICAL CABINET												
Refrigeration Charge (oz)	29	31	46	35	35	65	71	68	83	86	92	127
Air Coil Dimensions (HxL)	12 x 16.5	12 x 16.5	16 x 16.5	16.5 x 20	16.5 x 20	24 x 21	24 x 27	24 x 27	32 x 27	32 x 27	40 x 27	40 x 27
Standard Filter - 1-in. Throwaway (HxL)	15 x 20	15 x 20	18 x 20	20 x 20	20 x 20	24 x 24	24 x 30	24 x 30	16 x 30 (2)	16 x 30 (2)	20 x 30 (2)	20 x 30 (2)
Operating Weight (lb)	140	154	166	191	195	229	269	281	334	340	396	444
Shipping Weight (lb)	160	174	186	208	212	242	292	304	360	366	422	470
HORIZONTAL CABINET												
Refrigeration Charge (oz)	29	31	46	35	35	65	71	71	80	82	90	127
Air Coil Dimensions (HxL)	12 x 16.5	12 x 16.5	16 x 16.5	18 x 18.5	18 x 18.5	18 x 28	20 x 32.5	20 x 32.5	20 x 43.25	20 x 43.25	20 x 54	20 x 54
Standard Filter - 1-in. Throwaway (HxL)	15 x 20	15 x 20	18 x 20	18 x 20	18 x 20	20 x 30	20 x 34.5	20 x 34.5	20 x 24 (2)	20 x 24 (2)	20 x 28 (2)	20 x 28 (2)
Operating Weight (lb)	165	172	173	190	198	307	358	369	400	405	452	494
Shipping Weight (lb)	185	192	205	218	222	340	404	415	465	470	520	562

LEGEND

- ECM — Electronically Controlled Motor
 FPT — Female Pipe Thread

UNIT	A	B	C	D	E	F	G	H	J	K	M	N	P	Q	R	T	CONDENSER WATER CONNECTIONS	RECOMMENDED REPLACEMENT NOMINAL FILTER SIZE
	WIDTH	DEPTH	HEIGHT	CAB END TO FILTER RACK	R/A DUCT WIDTH	CAB FRONT TO FILTER RACK	WATER IN	WATER OUT	SIDE TO DISC.	DISC. WIDTH	TOP TO DISC. (FLE AND FRS)	DISC. HEIGHT	END TO DISC.	TOP TO DISC. (FRE AND FLS)	FILTER RACK HEIGHT	R/A DUCT FLANGE HEIGHT		
007	21.75	43.25	16.75	0.50	20.25	22.25	2.25	13.87	3.50	11.75	4.62	7.75	3.50	4.62	15.00	13.00	3/4 FPT	15 x 20 x 1
009	21.75	43.25	16.75	0.50	20.25	22.25	2.25	13.87	3.50	11.75	4.62	7.75	3.50	4.62	15.00	13.00	3/4 FPT	15 x 20 x 1
012	22.25	45.25	19.75	0.62	20.25	24.25	2.50	12.50	3.62	11.75	7.12	7.75	3.62	4.75	18.00	16.00	3/4 FPT	18 x 20 x 1
015	22.25	45.25	19.75	1.62	20.25	23.25	2.50	12.50	2.75	13.75	3.12	13.75	2.75	2.87	18.00	16.00	3/4 FPT	18 x 20 x 1
018	22.25	45.25	19.75	1.62	20.25	23.25	2.50	12.50	2.75	13.75	3.12	13.75	2.75	2.87	18.00	16.00	3/4 FPT	18 x 20 x 1
024	26.25	54.75	22.00*	1.25	30.25	23.00	2.62	15.12	3.75	13.75	2.12	15.75	3.75	4.25	20.12	18.00	3/4 FPT	20 x 30 x 1
030	30.25	68.25	22.00*	2.00	35.00	31.25	2.50	13.25	4.50	15.75	4.00	15.75	4.50	2.25	20.12	18.00	1 FPT	20 x 34.5 x 1
036	30.25	68.25	22.00*	2.00	35.00	31.25	2.50	13.25	4.50	15.75	4.00	15.75	4.50	2.25	20.12	18.00	1 FPT	20 x 34.5 x 1
042	30.25	79.00	22.00*	0.75	48.25	29.62	2.75	13.25	4.50	17.75	2.25	17.75	4.50	2.12	20.12	18.00	1 FPT	20 x 24 x 1 (2)
048	30.25	79.00	22.00*	0.75	48.25	29.62	2.75	13.25	4.50	17.75	2.25	17.75	4.50	2.12	20.12	18.00	1 FPT	20 x 24 x 1 (2)
060	30.25	89.25	22.00*	1.87	56.25	31.00	2.62	13.25	4.50	17.75	2.25	17.75	4.50	2.12	20.12	18.00	1 FPT	20 x 28 x 1 (2)
070	30.25	89.25	22.00*	1.87	56.25	31.00	5.75	17.75	4.87	17.75	2.62	17.75	4.87	1.75	20.12	18.00	1 FPT	20 x 28 x 1 (2)

NOTE: All dimensions in inches unless otherwise noted. All dimensions within ± 0.125-in. Specifications subject to change without notice.
 *Total unit height is 22.75 with base rails for 030-070 units.

LEGEND

- FLE — Front Water, Left Return, End Supply
- FLS — Front Water, Left Return, Straight Through Supply
- FRE — Front Water, Right Return, End Supply
- FRS — Front Water, Right Return, Straight Through Supply

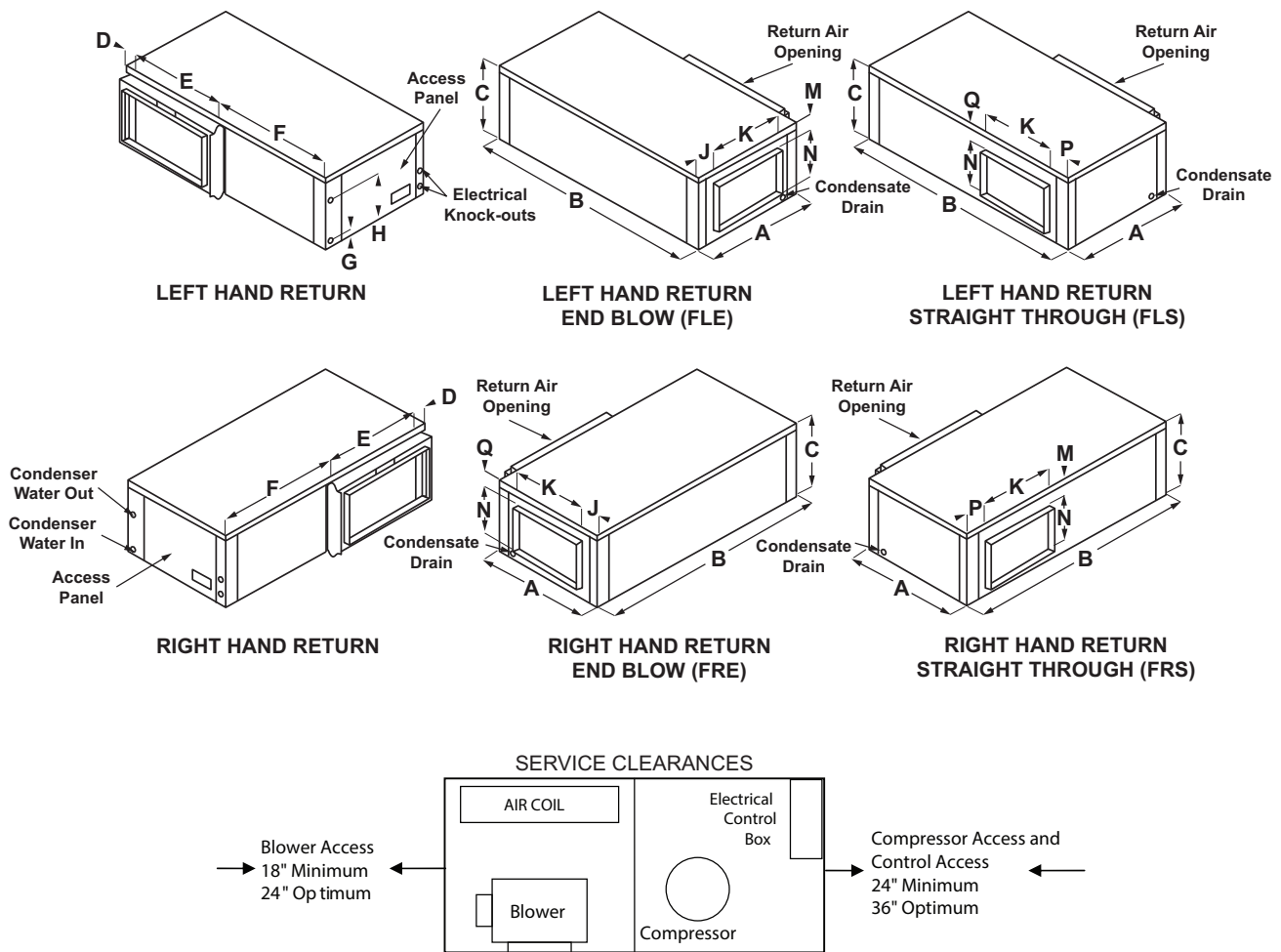

NOTE: The local electric codes may require 36-in. or more clearance at the electrical control box.

Fig. 1 — 50PSH007-070 Dimensional Data

UNIT	A	B	C	D	E	F	G	H	J	K	M	N	P	Q	CONDENSER WATER CONN.	RECOMMENDED REPLACEMENT NOMINAL FILTER SIZE
	WIDTH	DEPTH	HEIGHT	DISCHARGE DEPTH	DISCHARGE WIDTH	CABINET EDGE TO DISCHARGE	LEFT SIDE TO DISC.	WATER IN	BOTTOM TO COND. DRAIN	WATER OUT	R/A DUCT WIDTH	R/A DUCT FLANGE HEIGHT	FILTER RACK HEIGHT	RIGHT SIDE TO DISCHARGE		
007	21.75	21.75	32.75	11.75	7.75	5.00	8.50	2.25	8.00	13.75	18.00	13.00	15.00	8.50	3/4 FPT	15 x 20 x 1
009	21.75	21.75	32.75	11.75	7.75	5.00	8.50	2.25	8.00	13.75	18.00	13.00	15.00	8.50	3/4 FPT	15 x 20 x 1
012	21.75	21.75	32.75	11.75	7.75	5.00	8.50	2.62	7.50	12.50	18.00	16.00	18.00	8.50	3/4 FPT	18 x 20 x 1
015	21.75	21.75	39.25	13.75	13.75	4.00	6.12	2.25	7.50	12.25	18.00	18.00	20.00	4.00	3/4 FPT	20 x 20 x 1
018	21.75	21.75	39.25	13.75	13.75	4.00	6.12	2.25	7.50	12.25	18.00	18.00	20.00	4.00	3/4 FPT	20 x 20 x 1
024	21.75	26.25	47.25	13.75	15.75	6.25	4.87	2.50	8.75	15.00	22.00	22.00	24.00	4.00	3/4 FPT	24 x 24 x 1
030	24.25	33.50	47.25	15.75	15.75	8.87	7.00	2.50	8.50	14.50	28.00	22.00	24.00	4.00	1 FPT	24 x 30 x 1
036	24.25	33.50	47.25	15.75	15.75	8.87	7.00	2.50	8.50	14.50	28.00	22.00	24.00	4.00	1 FPT	24 x 30 x 1
042	26.25	33.50	58.25	17.75	17.75	7.87	6.75	3.25	8.50	13.25	28.00	30.00	32.00	4.00	1 FPT	16 x 30 x 1 (2)
048	26.25	33.50	58.25	17.75	17.75	7.87	6.75	3.25	8.50	13.25	28.00	30.00	32.00	4.00	1 FPT	16 x 30 x 1 (2)
060	26.25	33.50	66.25	17.75	17.75	7.87	7.00	3.25	8.50	13.25	28.00	38.00	40.00	4.00	1 FPT	20 x 30 x 1 (2)
070	26.25	33.50	66.25	17.75	17.75	7.87	7.25	4.25	10.00	17.00	28.00	38.00	40.00	3.00	1 FPT	20 x 30 x 1 (2)

NOTE: All dimensions in inches unless otherwise noted. All dimensions within ± 0.125-in. Specifications subject to change without notice.

LEGEND

- FLT — Front Water, Left Return, Top Supply
- FRT — Front Water, Left Return, Top Supply

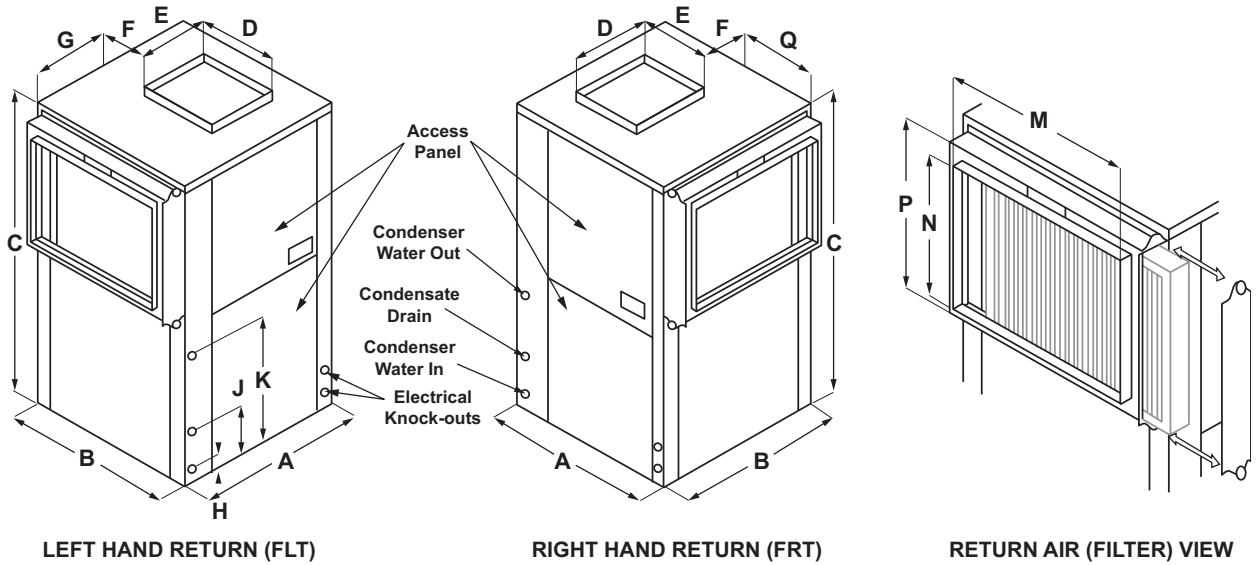

SERVICE CLEARANCES

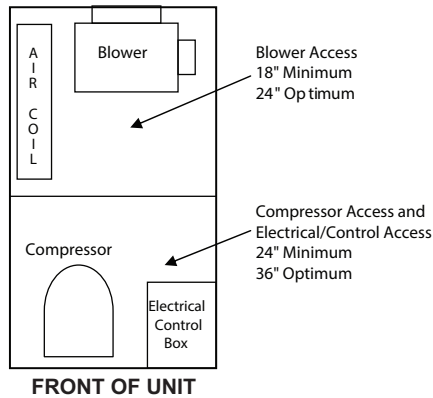

NOTE: The local electric codes may require 36-in. or more clearance at the electrical control box.

Fig. 2 — 50PSV007-070 Dimensional Data

Step 4 — Mount the Unit

VERTICAL UNITS (50PSV) — Vertical units up to 6 tons are available in left or right-hand return air configurations. Vertical units should be mounted level on a vibration absorbing pad slightly larger than the base to minimize vibration transmission to the building structure. It is not necessary to anchor the unit to the floor. See Fig. 3. If the unit is located in a confined space such as a closet, provisions must be made for return air to freely enter the space.

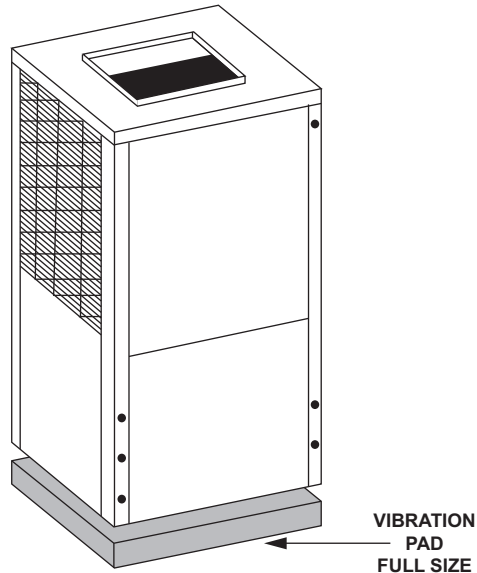

Fig. 3 — Vertical Unit on Vibration Pad

HORIZONTAL UNIT (50PSH) — While horizontal units may be installed on any level surface strong enough to hold their weight, they are typically suspended above a ceiling by threaded rods. The rods are usually attached to the unit corners by hanger bracket kits. See Fig. 4.

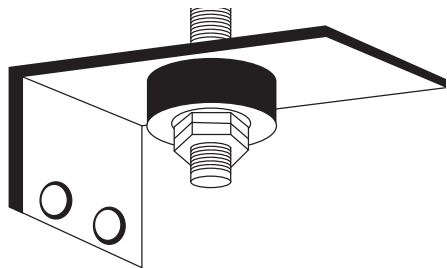

Fig. 4 — Typical Horizontal Unit Hanging Bracket

The rods must be securely anchored to the ceiling. Refer to the hanging bracket assembly and installation instructions for details. Horizontal units installed above the ceiling must conform to all local codes. An auxiliary drain pan, if required by code, should be at least four inches larger than the bottom of the heat pump. Plumbing connected to the heat pump must not come in direct contact with joists, trusses, walls, etc.

Some applications require an attic floor installation of the horizontal unit. In this case the unit should be set in a full size secondary drain pan on top of a vibration absorbing mesh. The secondary drain pan prevents possible condensate overflow or water leakage damage to the ceiling. The secondary drain pan is usually placed on a plywood base isolated from the ceiling joists by additional layers of vibration absorbing mesh. In both cases, a $\frac{3}{4}$ -in. drain connected to this secondary pan should be run to an eave and able to drain to a location that will be noticeable. If the unit is located in a crawl space, the bottom of the unit must be at least 4 in. above grade to prevent flooding of the electrical parts due to heavy rains.

Locate the heat pump unit in an area that provides sufficient room to make water and electrical connections, allowing easy removal of the access panels, and replacement of air filters for routine maintenance. This will ensure proper work space for service personnel to perform maintenance or repair.

See Fig. 1 and 2 for replacement filter sizes to ensure proper clearances are provided during installation. Allow adequate room below the unit for a condensate drain trap on horizontal units.

CAUTION

To avoid equipment damage, ensure that the heat pump unit is installed in a location or take the proper precautions in order to prevent rupturing the water coil due to freezing conditions.

The heat pump unit is designed for conditioned space installation only. If the source water is subjected to conditions where ambient temperatures can fall below freezing, some form of freeze protection should be employed. In an open loop system this may entail running the water pump continuously to prevent freezing. An antifreeze solution wherever possible should be used if water will be subject to freezing. Consult the factory in these instances for guidance.

Step 5 — Check Duct System — A supply air outlet collar and return air duct flange are provided on all units to facilitate duct connections. A flexible connector is recommended for supply and return air duct connections on metal duct systems. All metal ducting should be insulated with a minimum of 1 in. duct insulation to avoid heat loss or gain and prevent condensate forming during the cooling operation. Application of the unit to uninsulated duct work is not recommended as the unit's performance will be adversely affected. Do not connect ducts directly to the blower outlet; factory supplied duct collars should be used for the connection to minimize unit vibration and noise transmission to the ductwork and ultimately into the conditioned space. The factory-provided air filter must be removed when using a filter back return air grill. The factory filter should be left in place on a free return system.

If the unit will be installed in a new installation which includes new duct work, the installation should be designed using current ASHRAE (American Society of Heating, Refrigerating, and Air-Conditioning Engineers) procedures for duct sizing. If the unit is to be connected to existing ductwork, a check should be made to assure that the duct system has the capacity to handle the air required for the unit application. If the duct system is too small, larger ductwork should be installed. Check for existing leaks and repair as necessary to ensure a tight air seal within the duct. The duct system and all diffusers should be sized to handle the designed air flow quietly. To maximize sound attenuation of the unit blower, the supply and return air plenums should be insulated. There should be no direct straight air path thru the return air grille into the heat pump. The return air inlet to the heat pump must have at least one 90 degree turn away from the space return air grille. If air noise or excessive air flow are a problem, the blower speed can be changed to a lower speed to reduce air flow. (Refer to CFM motor speeds and settings in Table 2.)

WARNING

Always disconnect power to the unit before changing motor speed to prevent damage to the motor, injury or death due to electrical shock.

Table 2 — Motor CFM Selection (Constant Torque)

UNIT SIZE	MOTOR HP	TAP 1	TAP 2	TAP 3	TAP 4	TAP 5
015	1/3	LOW	MED	HIGH	—	—
018	1/3	LOW	MED	HIGH	—	—
024	1/3	LOW	MED	HIGH	—	—
030	1/2	LOW	MED	HIGH	—	—
036	3/4	LOW	MED	HIGH	—	—
042	3/4	LOW	MED	HIGH	—	—
048	3/4	LOW	MED	HIGH	—	—
060	1	LOW	MED	HIGH	—	—
070	1	LOW	MED	HIGH	—	—

Step 6 — Install Condensate Drain — A drain line must be connected to the heat pump and pitched away from the unit a minimum of 1/8 in. per foot to allow the condensate to flow away from the unit.

This connection must be in conformance with local plumbing codes. A trap must be installed in the condensate line to ensure free condensate flow. (Heat Pumps are not internally trapped). A vertical air vent is sometimes required to avoid air pockets. See Fig. 5. The length of the trap depends on the amount of positive or negative pressure on the drain pan. A second trap must not be included.

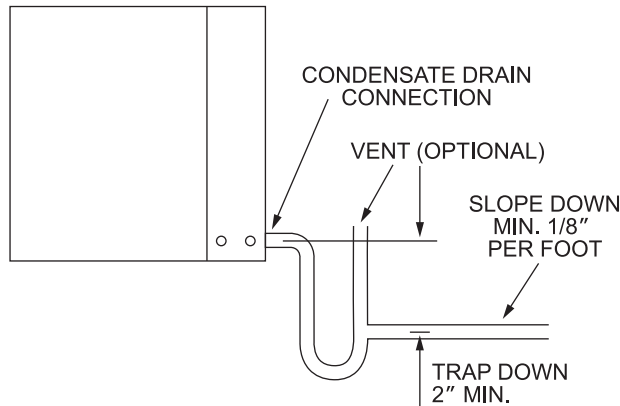

Fig. 5 — Condensate Trapping

The horizontal unit should be pitched approximately 1/4-in. towards the drain in both directions, to facilitate condensate removal. See Fig. 6.

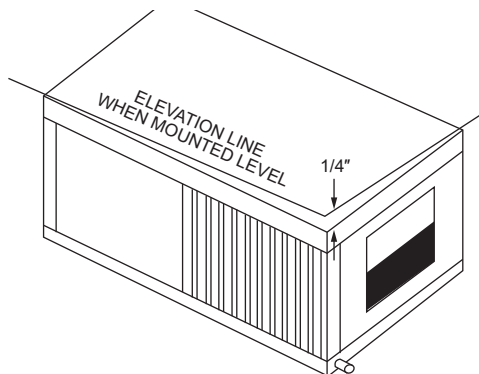

Fig. 6 — Sloped Horizontal Unit Installation

Step 7 — Pipe Connections — Depending on the application, there are 3 types of WSHP piping systems to choose from: water loop, ground-water and ground loop. Refer to Piping Section of Carrier System Design Manual for additional information.

All WSHP units use low temperature soldered female pipe thread fittings for water connections to prevent annealing and

out-of-round leak problems which are typically associated with high temperature brazed connections. Refer to Table 1 for connection sizes. When making piping connections, consider the following:

- Use a backup wrench when making screw connections to unit to prevent internal damage to piping.
- Insulation may be required on piping to avoid condensation in the case where fluid in loop piping operates at temperatures below dew point of adjacent air.
- Piping systems that contain steel pipes or fittings may be subject to galvanic corrosion. Dielectric fittings may be used to isolate the steel parts of the system to avoid galvanic corrosion.

WATER LOOP APPLICATIONS — Water loop applications usually include a number of units plumbed to a common piping system. Maintenance to any of these units can introduce air into the piping system. Therefore, air elimination equipment comprises a major portion of the mechanical room plumbing.

The flow rate is usually set between 2.25 and 3.5 gpm per ton of cooling capacity. For proper maintenance and servicing, pressure-temperature (P/T) ports are necessary for temperature and flow verification.

Cooling tower/boiler systems typically utilize a common loop maintained at 50 to 100 F. The use of a closed circuit evaporative cooling tower with a secondary heat exchange between the tower and the water loop is recommended. If an open type cooling tower is used continuously, chemical treatment and filtering will be necessary.

In addition to complying with any applicable codes, consider the following for system piping:

- Piping systems using water temperatures below 50 F require 1/2-in. closed cell insulation on all piping surfaces to eliminate condensation.
- Avoid all plastic to metal threaded fittings due to the potential to leak. Use a flange fitted substitute.
- Teflon tape thread sealant is recommended to minimize internal fouling of the heat exchanger.
- Use backup wrench. Do not overtighten connections.
- Route piping to avoid service access areas to unit.
- Flush the piping system prior to operation to remove dirt and foreign materials from the system.

GROUND-WATER APPLICATIONS — Typical ground-water piping is shown in Fig. 7. In addition to complying with any applicable codes, consider the following for system piping:

- Install shut-off valves for servicing.
- Install pressure-temperature plugs to measure flow and temperature.
- Connect boiler drains and other valves using a “T” connector to allow acid flushing for the heat exchanger.
- Do not overtighten connections.
- Route piping to avoid service access areas to unit.
- Use PVC SCH80 or copper piping material.

NOTE: PVC SCH40 should *not* be used due to system high pressure and temperature extremes.

Water Supply and Quantity — Check water supply. Water supply should be plentiful and of good quality. See Table 3 for water quality guidelines.

IMPORTANT: Failure to comply with the above required water quality and quantity limitations and the closed-system application design requirements may cause damage to the tube-in-tube heat exchanger. This damage is not the responsibility of the manufacturer.

In all applications, the quality of the water circulated through the heat exchanger must be within the ranges listed in the Water Quality Guidelines. Consult a local water firm, independent testing facility, or local water authority for specific rec-

ommendations to maintain water quality within the published limits.

GROUND-LOOP APPLICATIONS — Temperatures between 20 and 110 F and a cooling capacity of 2.25 to 3 gpm of flow per ton is recommended. In addition to complying with any applicable codes, consider the following for system piping:

- Limit piping materials to only polyethylene fusion in the buried sections of the loop.
- Do not use galvanized or steel fittings at any time due to corrosion.
- Avoid all plastic to metal threaded fittings due to the potential to leak. Use a flange fitted substitute.
- Do not overtighten connections.
- Route piping to avoid service access areas to unit.
- Use pressure-temperature (P/T) plugs to measure flow of pressure drop.

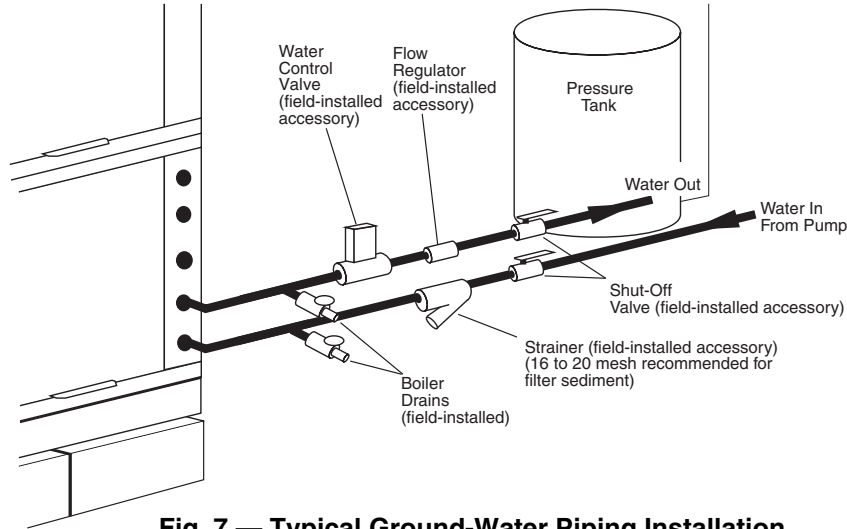

Fig. 7 — Typical Ground-Water Piping Installation

Table 3 — Water Quality Guidelines

CONDITION	HX MATERIAL*	CLOSED RECIRCULATING†	OPEN LOOP AND RECIRCULATING WELL**		
Scaling Potential — Primary Measurement					
Above the given limits, scaling is likely to occur. Scaling indexes should be calculated using the limits below.					
pH/Calcium Hardness Method	All	N/A	pH < 7.5 and Ca Hardness, <100 ppm		
Index Limits for Probable Scaling Situations (Operation outside these limits is not recommended.)					
Scaling indexes should be calculated at 150 F for direct use and HWG applications, and at 90 F for indirect HX use. A monitoring plan should be implemented.					
Ryznar Stability Index	All	N/A	6.0 - 7.5 If >7.5 minimize steel pipe use.		
Langelier Saturation Index	All	N/A	-0.5 to +0.5 If <-0.5 minimize steel pipe use. Based upon 150 F HWG and direct well, 85 F indirect well HX.		
Iron Fouling					
Iron Fe ²⁺ (Ferrous) (Bacterial Iron Potential)	All	N/A	<0.2 ppm (Ferrous) If Fe ²⁺ (ferrous) >0.2 ppm with pH 6 - 8, O ₂ <5 ppm check for iron bacteria.		
Iron Fouling	All	N/A	<0.5 ppm of Oxygen Above this level deposition will occur.		
Corrosion Prevention††					
pH	All	6 - 8.5 Monitor/treat as needed.	6 - 8.5 Minimize steel pipe below 7 and no open tanks with pH <8.		
Hydrogen Sulfide (H ₂ S)	All	N/A	<0.5 ppm At H ₂ S>0.2 ppm, avoid use of copper and cupronickel piping or HXs. Rotten egg smell appears at 0.5 ppm level. Copper alloy (bronze or brass) cast components are okay to <0.5 ppm.		
Ammonia Ion as Hydroxide, Chloride, Nitrate and Sulfate Compounds	All	N/A	<0.5 ppm		
Maximum Chloride Levels			Maximum allowable at maximum water temperature.		
			50 F (10 C)	75 F (24 C)	100 F (38 C)
	Copper	N/A	<20 ppm	NR	NR
	Cupronickel	N/A	<150 ppm	NR	NR
	304 SS	N/A	<400 ppm	<250 ppm	<150 ppm
	316 SS	N/A	<1000 ppm	<550 ppm	<375 ppm
	Titanium	N/A	>1000 ppm	>550 ppm	>375 ppm
Erosion and Clogging					
Particulate Size and Erosion	All	<10 ppm of particles and a maximum velocity of 6 fps. Filtered for maximum 800 micron size.	<10 ppm (<1 ppm "sandfree" for reinjection) of particles and a maximum velocity of 6 fps. Filtered for maximum 800 micron size. Any particulate that is not removed can potentially clog components.		
Brackish	All	N/A	Use cupronickel heat exchanger when concentrations of calcium or sodium chloride are greater than 125 ppm are present. (Seawater is approximately 25,000 ppm.)		

LEGEND

- HWG** — Hot Water Generator
- HX** — Heat Exchanger
- N/A** — Design Limits Not Applicable Considering Recirculating Potable Water
- NR** — Application Not Recommended
- SS** — Stainless Steel

*Heat exchanger materials considered are copper, cupronickel, 304 SS (stainless steel), 316 SS, titanium.

†Closed recirculating system is identified by a closed pressurized piping system.

**Recirculating open wells should observe the open recirculating design considerations.

††If the concentration of these corrosives exceeds the maximum allowable level, then the potential for serious corrosion problems exists. Sulfides in the water quickly oxidize when exposed to air, requiring that no agitation occur as the sample is taken. Unless tested immediately at the site, the sample will require stabilization with a few drops of one Molar zinc acetate solution, allowing accurate sulfide determination up to 24 hours after sampling. A low pH and high alkalinity can cause system problems, even when both values are within ranges shown. The term pH refers to the acidity, basicity, or neutrality of the water supply. Below 7.0, the water is considered to be acidic. Above 7.0, water is considered to be basic. Neutral water registers a pH of 7.0. To convert ppm to grains per gallon, divide by 17. Hardness in mg/l is equivalent to ppm. considered to be basic. Neutral water contains a pH of 7.0. To convert ppm to grains per gallon, divide by 17. Hardness in mg/l is equivalent to ppm.

INSTALLATION OF SUPPLY AND RETURN HOSE KIT — Follow these piping guidelines.

1. Install a drain valve at the base of each supply and return riser to facilitate system flushing.
2. Install shutoff/balancing valves and unions at each unit to permit unit removal for servicing.
3. Place strainers at the inlet of each system circulating pump.
4. Select the proper hose length to allow slack between connection points. Hoses may vary in length by +2% to -4% under pressure.
5. Refer to Table 4. Do not exceed the minimum bend radius for the hose selected. Exceeding the minimum bend radius may cause the hose to collapse, which reduces water flow rate. Install an angle adapter to avoid sharp bends in the hose when the radius falls below the required minimum.

NOTE: Piping must comply with all applicable codes.

Table 4 — Metal Hose Minimum Bend Radii

HOSE DIAMETER (in.)	MINIMUM BEND RADI (in.)
1/2	2 1/2
3/4	4
1	5 1/2

Insulation is not required on loop water piping except where the piping runs through unheated areas or outside the building or when the loop water temperature is below the minimum expected dew point of the pipe ambient. Insulation is required if loop water temperature drops below the dew point.

IMPORTANT: Do not bend or kink supply lines or hoses.

Pipe joint compound is not necessary when Teflon* threaded tape is pre-applied to hose assemblies or when flared-end connections are used. If pipe joint compound is preferred, use compound only in small amounts on the male pipe threads of the fitting adapters. Prevent sealant from reaching the flared surfaces of the joint.

NOTE: When anti-freeze is used in the loop, assure that it is compatible with Teflon tape or pipe joint compound employed.

Maximum allowable torque for brass fittings is 30 ft-lb. If a torque wrench is not available, tighten finger-tight plus one quarter turn. Tighten steel fittings as necessary.

Optional pressure-rated hose assemblies designed specifically for use with Carrier units are available. Similar hoses can be obtained from alternate suppliers. Supply and return hoses

are fitted with swivel-joint fittings at one end to prevent kinking during installation.

⚠ CAUTION

Backup wrench is required when tightening water connections to prevent water line damage. Failure to use a backup wrench could result in equipment damage.

Male adapters secure hose assemblies to the unit and risers. Install hose assemblies properly and check them regularly to avoid system failure and reduced service life. See Fig. 8.

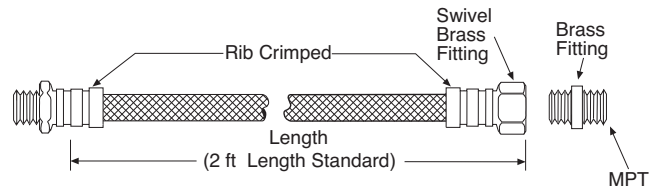

Fig. 8 — Supply/Return Hose Kit

Step 8 — Wire Field Power Supply

⚠ WARNING

To avoid possible injury or death due to electrical shock, open the power supply disconnect switch and secure it in an open position during installation.

⚠ CAUTION

Operating the unit with improper line voltage or with excessive phase imbalance is hazardous to the unit and constitutes abuse and is not covered under warranty.

All field wiring must comply with local and national fire, safety and electrical codes. Power to the unit must be within the operating voltage range indicated on the unit's nameplate. On three phase units, phases must be balanced within 2%. Properly sized fuses or HACR (Heating, Air-Conditioning, and Refrigeration) circuit breakers must be installed for branch circuit protection. See equipment rating plates for proper size.

The heat pump units are provided with a concentric knock-out in the front right corner post for attaching common trade sizes of conduit. Route power supply wiring through this opening. Flexible wiring and conduit should be used to isolate vibration and noise from the building structure. Be certain to connect the ground lead to the ground lug in the control box. Connect the power leads as indicated on the unit wiring diagrams. See Fig. 9-20. See Table 5 and 6 for additional electrical data.

* Registered trademark of DuPont.

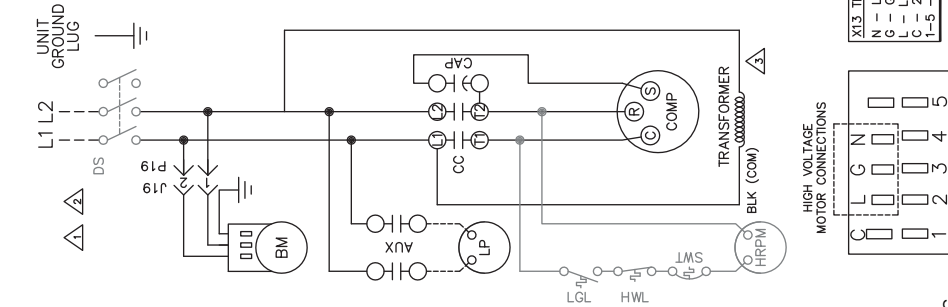
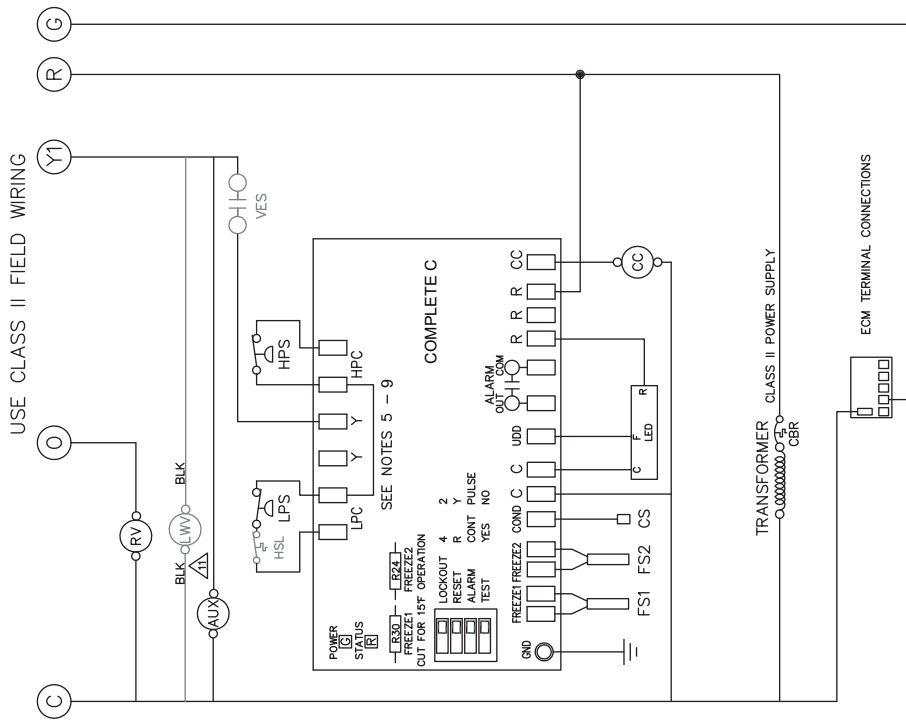

UPH STATUS LED - BLINK CODES	
1	HIGH PRESSURE FAULT
2	LOW PRESSURE FAULT
3	CONDENSER FREEZE CONDITION
4	CONDENSATE OVERFLOW FAULT
5	BROWNOUT FAULT
6	EVAPORATOR FREEZE CONDITION

FACTORY WIRE ———
FIELD WIRE - - - - -

STANDARD COMPONENTS LEGEND:

- AUX - AUXILIARY RELAY (FOR LOOP PUMP, ETC)
- BM - BLOWER MOTOR
- COMP - COMPRESSOR
- CBR - 24V CIRCUIT BREAKER
- CAP - COMPRESSOR CAPACITOR
- CC - COMPRESSOR CONTACTOR
- CS - CONDENSATE SENSOR (IN DRAIN PAN)
- FS - FREEZE SENSOR
- HPS - HIGH PRESSURE SWITCH
- LP - LOOP PUMP
- LED - UNIT STATUS LED
- LPS - LOW PRESSURE SWITCH
- RV - REVERSE VALVE(HEAT PUMPS)

OPTIONAL COMPONENTS LEGEND:

- [] DS - DISCONNECT SWITCH
- [] HSL - HIGH TEMP SUCTION LIMIT (WITH HOT GAS BYPASS ONLY)
- [] LWV - LEAVING WATER VALVE
- [] VES - VALVE END SWITCH
- [] HRP - HEAT RECOVERY PACKAGE, INCLUDES: HRPW- HEAT RECOVERY PUMP LGL - LOW GAS TEMP LIMIT HWL - HOT WATER LIMIT SWT - ON/OFF SWITCH OVERLOAD PROTECTION

NOTES:

1. SEE UNIT NAMEPLATE FOR ELECTRICAL RATING.
2. ALL FIELD WIRING MUST BE IN ACCORDANCE WITH NEC-NFPA #70. COPPER CONDUCTORS ONLY.
3. 208/230V UNITS ARE FACTORY WIRED FOR 230V OPERATION. FOR 208V OPERATION, REMOVE LEAD FROM 240 TERMINAL AND CONNECT IT TO 208. CAP ALL UNUSED TERMINALS.
4. UPM-1 INCLUDES BUILT IN: 270-300 SECOND RANDOM START
300 SECOND DELAY ON BREAK
120 SECOND LOW PRESSURE BYPASS
5. "TEST" DIP SWITCH REDUCES DELAYS TO 10 SEC WHEN SET TO YES. MUST BE SET TO "NO" FOR NORMAL OPERATION.
6. "FREEZE SENSOR" ON CONDENSER WILL OPERATE AT 26 F BY DEFAULT. IF 15 F OPERATION IS REQUIRED JUMPER R30 MUST BE CUT. IF FREEZE SENSOR IS NOT INSTALLED A JUMPER SHALL BE INSTALLED BETWEEN THE FREEZE1 OR FREEZE2 SENSOR TERMINALS.
7. "ALARM OUTPUT" DIP SWITCH MUST BE SET TO "PULSE" IF BLINKING T-STAT SERVICE LIGHT IS DESIRED.
8. DEFAULT SETTINGS FOR COMPLETE C BOARD FROM FACTORY SHOWN.
9. ALARM OUTPUT IS NORMALLY OPEN (NO) DRY CONTACT. IF 24 VAC IS NEEDED, CONNECT R TO ALR-COM TERMINAL. 24 VAC WILL BE SENSED ON THE ALR-OUT WHEN THE UNIT IS IN ALARM CONDITION. OUTPUT WILL BE PULSED IF PULSE IS SELECTED.
10. FACTORY-MOUNTED LOOP PUMP OR TWO-WAY WATER VALVE. BOTH DEVICES WILL NOT BE PRESENT IN THE SAME UNIT.

Fig. 9 — Constant Torque Motor, Single Phase/Single Stage, Complete C Control

UPM STATUS LED - BLINK CODES
1 HIGH PRESSURE FAULT
2 LOW PRESSURE FAULT
3 CONDENSER FREEZE CONDITION
4 CONDENSATE OVERFLOW FAULT
5 BLOWING/OUT FAULT
6 EVAPORATOR FREEZE CONDITION

FACTORY WIRE ———
FIELD WIRE - - - - -

STANDARD COMPONENTS LEGEND:

- AUX - AUXILIARY RELAY (FOR LOOP PUMP, ETC)
- BC - BLOWER MOTOR CAPACITOR
- BM - BLOWER MOTOR
- COMP - COMPRESSOR
- CBR - 24V CIRCUIT BREAKER
- CAP - COMPRESSOR CAPACITOR
- CBR - COMPRESSOR CONTACTOR
- CS - CONDENSATE SENSOR (IN DRAIN PAN)
- FS - FREEZE SENSOR
- HPS - HIGH PRESSURE SWITCH
- LP - LOOP PUMP
- LED - UNIT STATUS LED
- LPS - LOW PRESSURE SWITCH
- RV - REVERSE VALVE(HEAT PUMPS)

OPTIONAL COMPONENTS LEGEND:

- [] DS - DISCONNECT SWITCH
- [] HSL - HIGH TEMP SUCTION LIMIT (WITH HOT GAS BYPASS ONLY)
- [] LWV - LEAVING WATER VALVE
- [] VES - VALVE END SWITCH
- [] HRP - HEAT RECOVERY PACKAGE, INCLUDES: HRP - HEAT RECOVERY PUMP
- LGL - LOW GAS TEMP LIMIT
- HWL - HOT WATER LIMIT
- SWT - ON/OFF SWITCH OVERLOAD PROTECTION

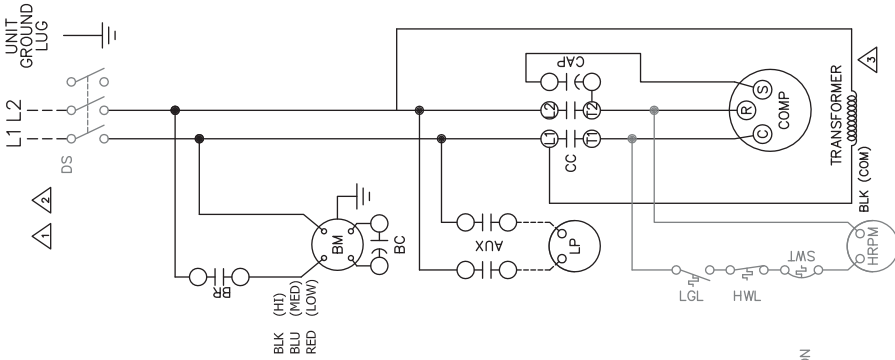

NOTES:

1. SEE UNIT NAMEPLATE FOR ELECTRICAL RATING.
2. ALL FIELD WIRING MUST BE IN ACCORDANCE WITH NEC-NFPA #70, COPPER CONDUCTORS ONLY.
3. 208/230V UNITS ARE FACTORY WIRED FOR 230V OPERATION. FOR 208V OPERATION, REMOVE LEAD FROM 240 TERMINAL AND CONNECT IT TO 208. CAP ALL UNUSED TERMINALS.
4. UPM-1 INCLUDES BUILT IN: 270-300 SECOND RANDOM START
300 SECOND DELAY ON BREAK
120 SECOND LOW PRESSURE BYPASS
5. "TEST" DIP SWITCH REDUCES DELAYS TO 10 SEC WHEN SET TO YES. MUST BE SET TO "NO" FOR NORMAL OPERATION.
6. "FREEZE SENSOR" ON CONDENSER WILL OPERATE AT 26 F BY DEFAULT. IF 15 F OPERATION IS REQUIRED JUMPER R30 MUST BE CUT. IF FREEZE SENSOR IS NOT INSTALLED A JUMPER SHALL BE INSTALLED BETWEEN THE FREEZE1 OR FREEZE2 SENSOR TERMINALS.
7. "ALARM OUTPUT" DIP SWITCH MUST BE SET TO "PULSE" IF BLINKING T-STAT SERVICE LIGHT IS DESIRED.
8. DEFAULT SETTINGS FOR COMPLETE C BOARD FROM FACTORY SHOWN.
9. ALARM OUTPUT IS NORMALLY OPEN (NO) DRY CONTACT. IF 24 VAC IS NEEDED, CONNECT R TO ALR-COM TERMINAL. 24 VAC WILL BE SENSED ON THE ALR-OUT WHEN THE UNIT IS IN ALARM CONDITION. OUTPUT WILL BE PULSED IF PULSE IS SELECTED.
10. FACTORY-MOUNTED LOOP PUMP OR TWO-WAY WATER VALVE. BOTH DEVICES WILL NOT BE PRESENT IN THE SAME UNIT.

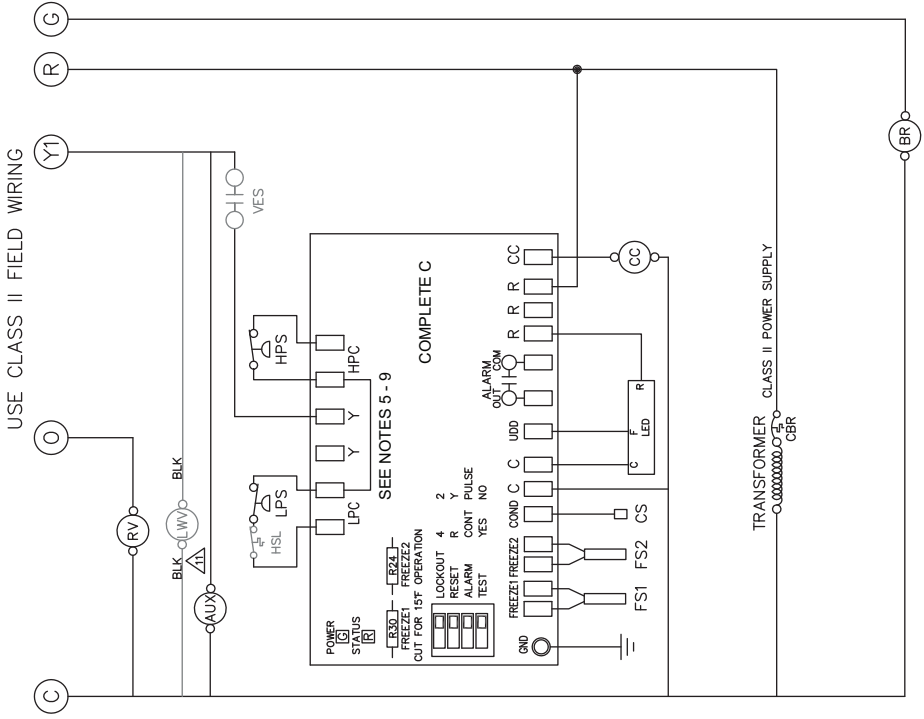

Fig. 10 — PSC Motor, Single Phase/Single Stage, Complete C Control

UIM STATUS LED - BLINK CODES
1 HIGH PRESSURE FAULT
2 LOW PRESSURE FAULT
3 CONDENSER FRIEZE CONDITION
4 CONDENSATE OVERFLOW FAULT
5 BROWNOUT FAULT
6 EVAPORATOR FRIEZE CONDITION

FACTORY WIRE ———
FIELD WIRE - - - - -

STANDARD COMPONENTS LEGEND:

- AUX - AUXILIARY RELAY (FOR LOP PUMP, ETC)
 BM - BLOWER MOTOR
 COMP - COMPRESSOR
 CBR - 24V CIRCUIT BREAKER
 CAP - COMPRESSOR CAPACITOR
 CC - COMPRESSOR CONTACTOR
 CS - CONDENSATE SENSOR (IN DRAIN PAN)
 FS - FREEZE SENSOR
 HPS - HIGH PRESSURE SWITCH
 LP - LOOP PUMP
 LED - UNIT STATUS LED
 LPS - LOW PRESSURE SWITCH
 RV - REVERSE VALVE(HEAT PUMPS)

OPTIONAL COMPONENTS LEGEND:

- [] DS - DISCONNECT SWITCH
 [] HSL - HIGH TEMP SUCTION LIMIT (WITH HOT GAS BYPASS ONLY)
 [] LWV - LEAVING WATER VALVE
 [] VES - VALVE END SWITCH
 [] HRP - HEAT RECOVERY PACKAGE, INCLUDES:
 HRP-M - HEAT RECOVERY PUMP
 LGL - LOW GAS TEMP LIMIT
 HWL - HOT WATER LIMIT
 SWT - ON/OFF SWITCH OVERLOAD PROTECTION

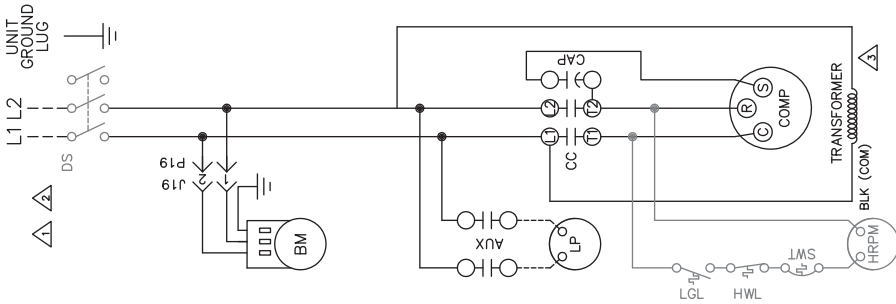

NOTES:

- SEE UNIT NAMEPLATE FOR ELECTRICAL RATING.
- ALL FIELD WIRING MUST BE IN ACCORDANCE WITH NEC-NFPA #70. COPPER CONDUCTORS ONLY.
- 208/230V UNITS ARE FACTORY WIRED FOR 230V OPERATION. FOR 208V OPERATION, REMOVE LEAD FROM 240 TERMINAL AND CONNECT IT TO 208. CAP ALL UNUSED TERMINALS.
- UPM-1 INCLUDES BUILT IN: 270-300 SECOND RANDOM START
300 SECOND DELAY ON BREAK
120 SECOND LOW PRESSURE BYPASS
- "TEST" DIP SWITCH REDUCES DELAYS TO 10 SEC WHEN SET TO YES. MUST BE SET TO "NO" FOR NORMAL OPERATION.
- "FREEZE SENSOR" ON CONDENSER WILL OPERATE AT 26 F BY DEFAULT, IF 15 F OPERATION IS REQUIRED JUMPER R30 MUST BE CUT. IF FREEZE SENSOR IS NOT INSTALLED A JUMPER SHALL BE INSTALLED BETWEEN THE FREEZE1 OR FREEZE2 SENSOR TERMINALS.
- "ALARM OUTPUT" DIP SWITCH MUST BE SET TO "PULSE" IF BLINKING T-STAT SERVICE LIGHT IS DESIRED.
- DEFAULT SETTINGS FOR COMPLETE C BOARD FROM FACTORY SHOWN.
- ALARM OUTPUT IS NORMALLY OPEN (NO) DRY CONTACT. IF 24 VAC IS NEEDED, CONNECT R TO ALR-COM TERMINAL. 24 VAC WILL BE SENSED ON THE ALR-OUT WHEN THE UNIT IS IN ALARM CONDITION. OUTPUT WILL BE PULSED IF PULSE IS SELECTED.
- FACTORY-MOUNTED LOOP PUMP OR TWO-WAY WATER VALVE. BOTH DEVICES WILL NOT BE PRESENT IN THE SAME UNIT.

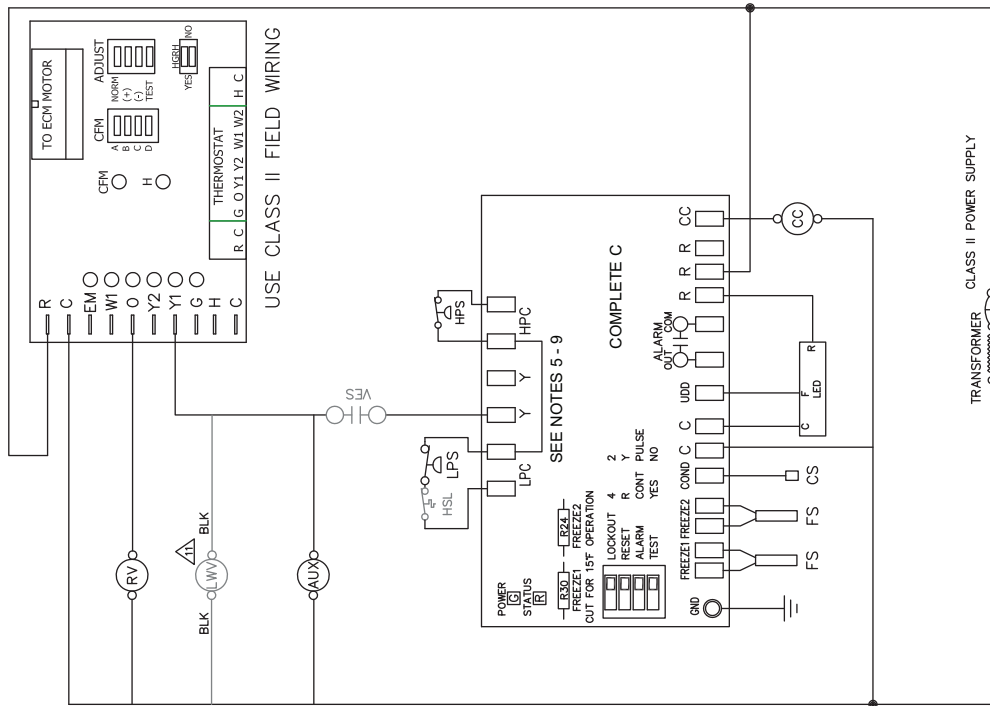

USE CLASS II FIELD WIRING

Fig. 11 — EON Motor, Single Phase/Single Stage, Complete C Control

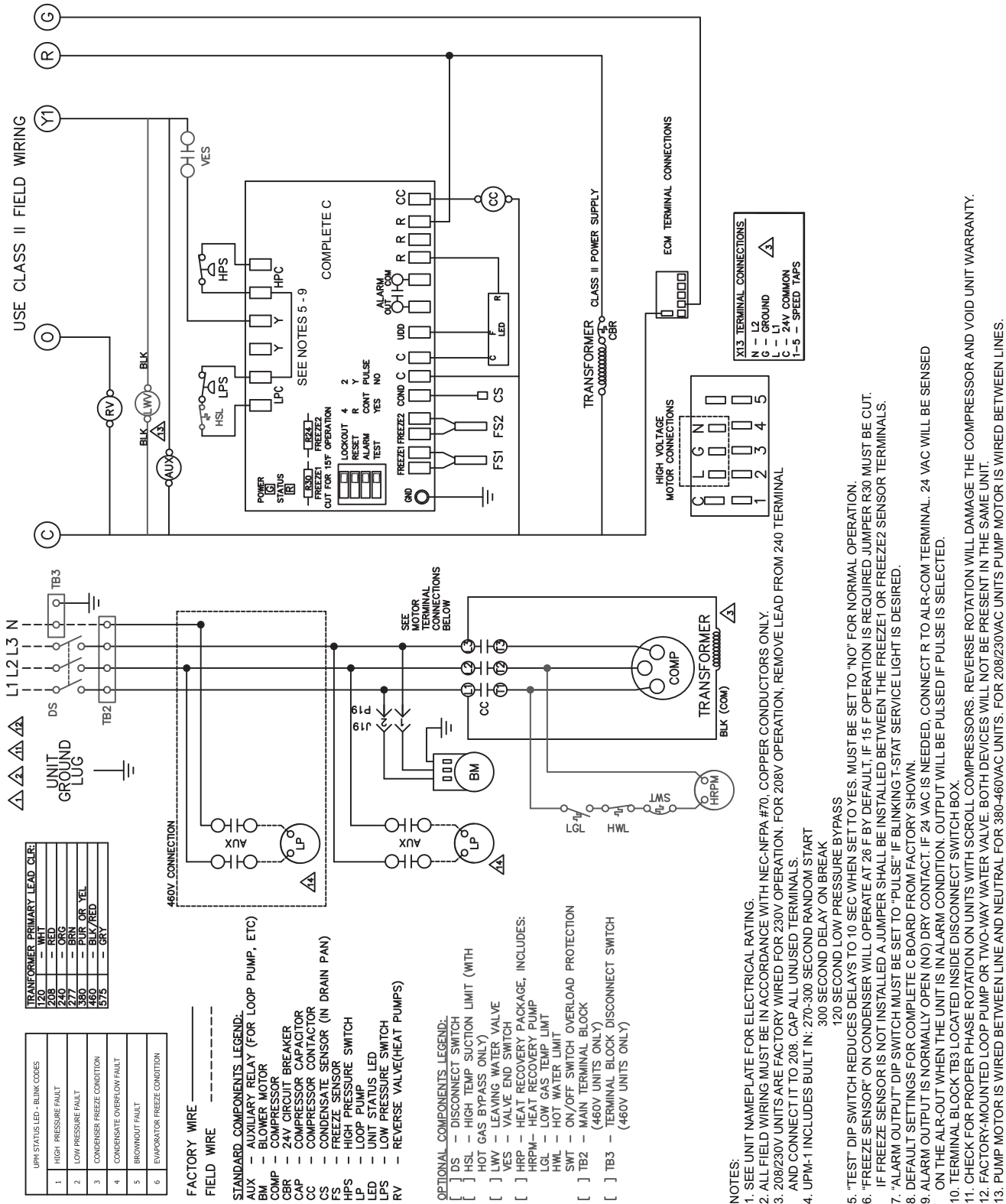

Fig. 12 — Constant Torque Motor, Three Phase/Single Stage, Complete C Control

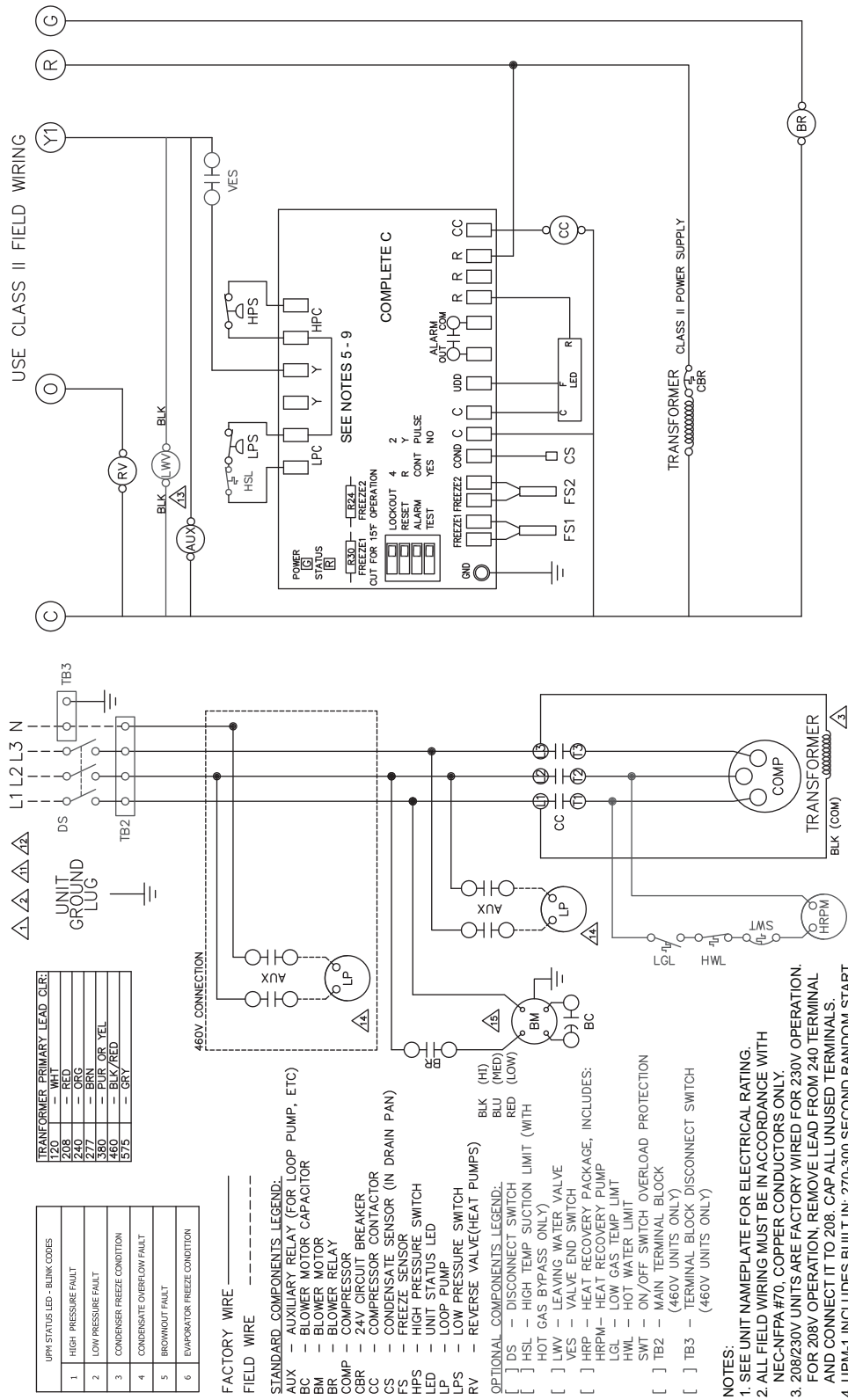
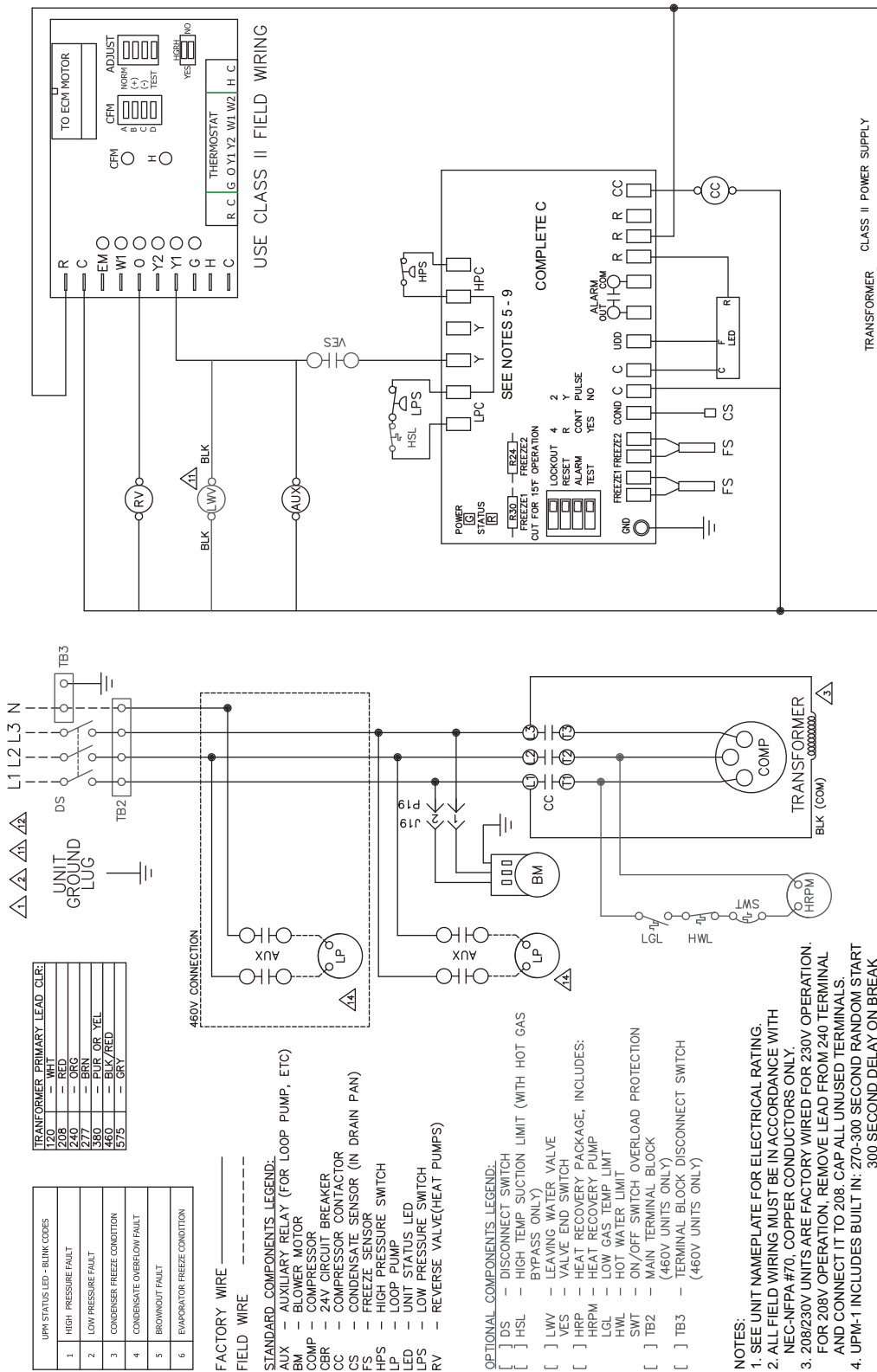

Fig. 13 — PSC Motor, Three Phase/Single Stage, Complete C Control



UPM STATUS LED - BLINK CODES	TRANSFORMER PRIMARY LEAD COLOR
1 HIGH PRESSURE FAULT	120 - WHIT
2 LOW PRESSURE FAULT	208 - RED
3 CONDENSER FREEZE CONDITION	240 - ORG
4 CONDENSATE OVERFLOW FAULT	277 - BRN
5 BROWNOUT FAULT	480 - BLK/GR YEL
6 EVAPORATOR FREEZE CONDITION	575 - BLK/RED
	575 - GRK

- STANDARD COMPONENTS LEGEND:**
- AUX - AUXILIARY RELAY (FOR LOOP PUMP, ETC)
 - BM - BLOWER MOTOR
 - COMP - COMPRESSOR
 - CBR - 24V CIRCUIT BREAKER
 - CC - COMPRESSOR CONTACTOR
 - CS - CONDENSATE SENSOR (IN DRAIN PAN)
 - FS - FREEZE SENSOR
 - HPS - HIGH PRESSURE SWITCH
 - LP - LOOP PUMP
 - LED - UNIT STATUS LED
 - LPS - LOW PRESSURE SWITCH
 - RV - REVERSE VALVE (HEAT PUMPS)

- OPTIONAL COMPONENTS LEGEND:**
- [] DS - DISCONNECT SWITCH
 - [] HSL - HIGH TEMP SUCTION LIMIT (WITH HOT GAS BYPASS ONLY)
 - [] LWV - LEAVING WATER VALVE
 - [] YES - VALVE END SWITCH
 - [] HRP - HEAT RECOVERY PACKAGE, INCLUDES: HGRM - HEAT RECOVERY PUMP LGL - LOW GAS TEMP LIMIT
 - [] HWL - HOT WATER LIMIT
 - [] SWT - ON/OFF SWITCH OVERLOAD PROTECTION
 - [] TB2 - MAIN TERMINAL BLOCK (460V UNITS ONLY)
 - [] TB3 - TERMINAL BLOCK DISCONNECT SWITCH (460V UNITS ONLY)

- NOTES:**
1. SEE UNIT NAMEPLATE FOR ELECTRICAL RATING.
 2. ALL FIELD WIRING MUST BE IN ACCORDANCE WITH NEC-NFPA #70. COPPER CONDUCTORS ONLY.
 3. 208/230V UNITS ARE FACTORY WIRED FOR 230V OPERATION. FOR 208V OPERATION, REMOVE LEAD FROM 240 TERMINAL AND CONNECT IT TO 208. CAP ALL UNUSED TERMINALS.
 4. UPM-1 INCLUDES BUILT IN: 270-300 SECOND RANDOM START 300 SECOND DELAY ON BREAK 120 SECOND LOW PRESSURE BYPASS

5. "TEST" DIP SWITCH REDUCES DELAYS TO 10 SEC WHEN SET TO YES. MUST BE SET TO "NO" FOR NORMAL OPERATION.
6. "FREEZE SENSOR" ON CONDENSER WILL OPERATE AT 28 F BY DEFAULT. IF 15 F OPERATION IS REQUIRED JUMPER R30 MUST BE CUT.
7. "ALARM OUTPUT" DIP SWITCH MUST BE SET TO "PULSE" IF BLINKING T-STAT SERVICE LIGHT IS DESIRED.
8. DEFAULT SETTINGS FOR COMPLETE C BOARD FROM FACTORY SHOWN.
9. ALARM OUTPUT IS NORMALLY OPEN (NO) DRY CONTACT. IF 24 VAC IS NEEDED, CONNECT R TO ALR-COM TERMINAL. 24 VAC WILL BE SENSED ON THE ALR-OUT WHEN THE UNIT IS IN ALARM CONDITION. OUTPUT WILL BE PULSED IF PULSE IS SELECTED.
10. TERMINAL BLOCK TB3 LOCATED INSIDE DISCONNECT SWITCH BOX.
11. CHECK FOR PROPER PHASE ROTATION ON UNITS WITH SCROLL COMPRESSORS. REVERSE ROTATION WILL DAMAGE THE COMPRESSOR AND VOID UNIT WARRANTY.
12. FACTORY-MOUNTED LOOP PUMP OR TWO-WAY WATER VALVE. BOTH DEVICES WILL NOT BE PRESENT IN THE SAME UNIT.
13. PUMP MOTOR IS WIRED BETWEEN LINE AND NEUTRAL FOR 380-460VAC UNITS. FOR 208/230VAC UNITS PUMP MOTOR IS WIRED BETWEEN LINES.

Fig. 14 — EON Motor, Three Phase/Single Stage, Complete C Control

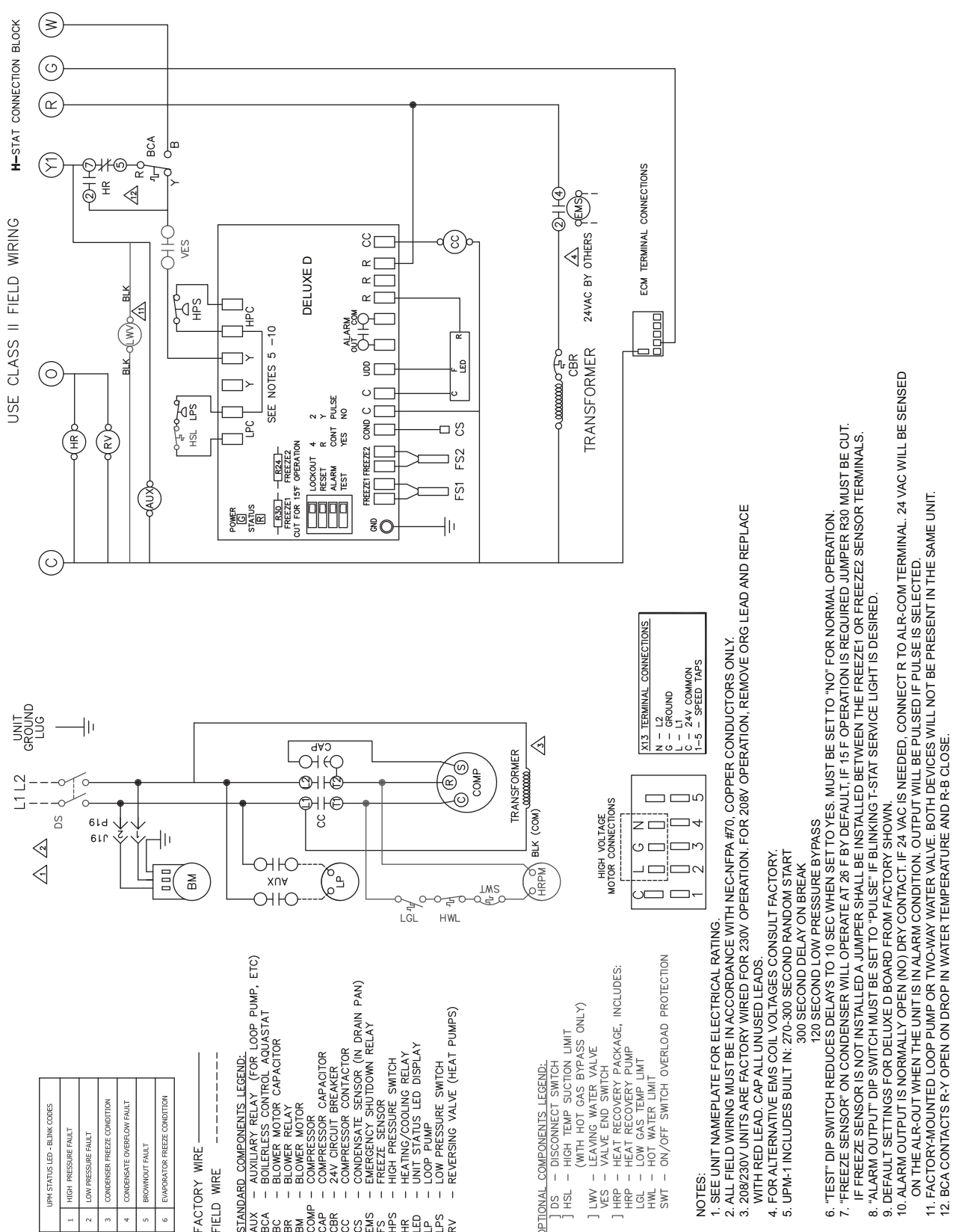

USE CLASS II FIELD WIRING

H-STAT CONNECTION BLOCK

UPM STATUS LED - BLINK CODES
1 HIGH PRESSURE FAULT
2 LOW PRESSURE FAULT
3 CONDENSER FREEZE CONDITION
4 CONDENSATE OVERFLOW FAULT
5 BROWNOUT FAULT
6 EVAPORATOR FREEZE CONDITION

FACTORY WIRE ———
FIELD WIRE - - - - -

STANDARD COMPONENTS LEGEND:

- AUX - AUXILIARY RELAY (FOR LOOP PUMP, ETC)
- BCA - BOILERLESS CONTROL AQUASTAT
- BC - BLOWER MOTOR CAPACITOR
- BM - BLOWER MOTOR
- COMP - COMPRESSOR
- CAP - CAPACITOR
- CBR - 2-POLE CIRCUIT BREAKER
- CC - COMPRESSOR CONTACTOR
- COND - CONDENSATE SENSOR (IN DRAIN PAN)
- FS - FREEZE SENSOR
- FSW - FREEZE SWITCH/DOWN RELAY
- HPS - HIGH PRESSURE SWITCH
- HR - HEATING/COOLING RELAY
- LED - UNIT STATUS LED DISPLAY
- LP - LOOP PUMP
- LPS - LOW PRESSURE SWITCH (HEAT PUMPS)
- RV - REVERSING VALVE (HEAT PUMPS)

OPTIONAL COMPONENTS LEGEND:

- [] DS - DISCONNECT SWITCH
- [] HSL - HIGH TEMP SUCTION LIMIT (WITH HOT GAS BYPASS ONLY)
- [] LWV - LEAVING WATER VALVE
- [] VES - VALVE END SWITCH
- [] HRP - HEAT RECOVERY PACKAGE, INCLUDES: HRP - HEAT RECOVERY PUMP LGL - LOW GAS TEMP LIMIT HWL - HOT WATER LIMIT SWT - ON/OFF SWITCH OVERLOAD PROTECTION

NOTES:

1. SEE UNIT NAMEPLATE FOR ELECTRICAL RATING.
2. ALL FIELD WIRING MUST BE IN ACCORDANCE WITH NEC-NFPA #70. COPPER CONDUCTORS ONLY.
3. 208/230V UNITS ARE FACTORY WIRED FOR 230V OPERATION. FOR 208V OPERATION, REMOVE ORG LEAD AND REPLACE WITH RED LEAD. CAP ALL UNUSED LEADS.
4. FOR ALTERNATIVE EMS COIL VOLTAGES CONSULT FACTORY.
5. UPM-1 INCLUDES BUILT IN: 270-300 SECOND RANDOM START 300 SECOND DELAY ON BREAK 120 SECOND LOW PRESSURE BYPASS
6. "TEST" DIP SWITCH REDUCES DELAYS TO 10 SEC WHEN SET TO YES. MUST BE SET TO "NO" FOR NORMAL OPERATION.
7. "FREEZE SENSOR" ON CONDENSER WILL OPERATE AT 26 F BY DEFAULT; IF 15 F OPERATION IS REQUIRED JUMPER R30 MUST BE CUT.
8. "ALARM OUTPUT" DIP SWITCH MUST BE SET TO "PULSE" IF BLINKING T-STAT SERVICE LIGHT IS DESIRED.
9. DEFAULT SETTINGS FOR DELUXE D BOARD FROM FACTORY SHOWN.
10. ALARM OUTPUT IS NORMALLY OPEN (NO) DRY CONTACT. IF 24 VAC IS NEEDED, CONNECT R TO ALR-COM TERMINAL. 24 VAC WILL BE SENSED ON THE ALR-OUT WHEN THE UNIT IS IN ALARM CONDITION. OUTPUT WILL BE PULSED IF PULSE IS SELECTED.
11. FACTORY-MOUNTED LOOP PUMP OR TWO-WAY WATER VALVE. BOTH DEVICES WILL NOT BE PRESENT IN THE SAME UNIT.
12. BCA CONTACTS R-Y OPEN ON/DROP IN WATER TEMPERATURE AND R-B CLOSE.

Fig. 15 — Constant Torque Motor, Single Phase/Single Stage, Deluxe D Control

UPM STATUS LED - BLINK CODES
1 HIGH PRESSURE FAULT
2 LOW PRESSURE FAULT
3 CONDENSER FREEZE CONDITION
4 CONDENSATE OVERFLOW FAULT
5 BROWNOUT FAULT
6 EVAPORATOR FREEZE CONDITION

FACTORY WIRE ———
FIELD WIRE - - - - -

STANDARD COMPONENTS LEGEND:
 AUX - AUXILIARY RELAY (FOR LOOP PUMP, ETC)
 BCA - BOILERLESS CONTROL AQUASTAT
 BM - BLOWER MOTOR
 COMP - COMPRESSOR
 CBR - 24 VOLT BREAKER
 CC - COMPRESSOR CONTACTOR
 CS - CONDENSATE SENSOR (IN DRAIN PAN)
 EMS - EMERGENCY SHUTDOWN RELAY
 FS - FREEZE SENSOR
 HPS - HIGH PRESSURE SWITCH
 HR - HEATING/COOLING RELAY
 LED - UNIT STATUS LED DISPLAY
 LP - LOOP PUMP
 LPS - LOW PRESSURE SWITCH
 RV - REVERSING VALVE (HEAT PUMPS)

OPTIONAL COMPONENTS LEGEND:
 [] DS - DISCONNECT SWITCH
 [] HSL - HIGH TEMP SUCTION LIMIT (WITH HOT GAS BYPASS ONLY)
 [] LWV - LEAVING WATER VALVE
 [] YES - VALVE END SWITCH
 [] HRP - HEAT RECOVERY PACKAGE, INCLUDES: HRP - HEAT RECOVERY PUMP
 LCL - LOW GAS TEMP LIMIT
 HWL - HOT WATER LIMIT
 SWT - ON/OFF SWITCH OVERLOAD PROTECTION

- NOTES:**
1. SEE UNIT NAMEPLATE FOR ELECTRICAL RATING.
 2. ALL FIELD WIRING MUST BE IN ACCORDANCE WITH NEC-NFPA #70, COPPER CONDUCTORS ONLY.
 3. 208/230V UNITS ARE FACTORY WIRING FOR 230V OPERATION. FOR 208V OPERATION, REMOVE ORG LEAD AND REPLACE WITH RED LEAD. CAP ALL UNUSED LEADS.
 4. FOR ALTERNATIVE EMS COIL VOLTAGES CONSULT FACTORY.
 5. UPM-1 INCLUDES BUILT IN: 270-300 SECOND RANDOM START 300 SECOND DELAY ON BREAK 120 SECOND LOW PRESSURE BYPASS
 6. "TEST" DIP SWITCH REDUCES DELAYS TO 10 SEC WHEN SET TO YES. MUST BE SET TO "NO" FOR NORMAL OPERATION.
 7. "FREEZE SENSOR" ON CONDENSER WILL OPERATE AT 26 F BY DEFAULT. IF 15 F OPERATION IS REQUIRED JUMPER R30 MUST BE CUT. IF FREEZE SENSOR IS NOT INSTALLED A JUMPER SHALL BE INSTALLED BETWEEN THE FREEZE1 OR FREEZE2 SENSOR TERMINALS.
 8. "ALARM OUTPUT" DIP SWITCH MUST BE SET TO "PULSE" IF BLINKING T-STAT SERVICE LIGHT IS DESIRED.
 9. DEFAULT SETTINGS FOR DELUXE D BOARD FROM FACTORY SHOWN
 10. ALARM OUTPUT IS NORMALLY OPEN (NO) DRY CONTACT. IF 24 VAC IS NEEDED, CONNECT R TO ALR-COM TERMINAL. 24 VAC WILL BE SENSED ON THE ALR-OUT WHEN THE UNIT IS IN ALARM CONDITION. OUTPUT WILL BE PULSED IF PULSE IS SELECTED.
 11. FACTORY-MOUNTED LOOP PUMP OR TWO-WAY WATER VALVE. BOTH DEVICES WILL NOT BE PRESENT IN THE SAME UNIT.
 12. BCA CONTACTS R-Y OPEN ON DROP IN WATER TEMPERATURE AND R-B CLOSE.

Fig. 16 — PSC Motor, Single Phase/Single Stage, Deluxe D Control

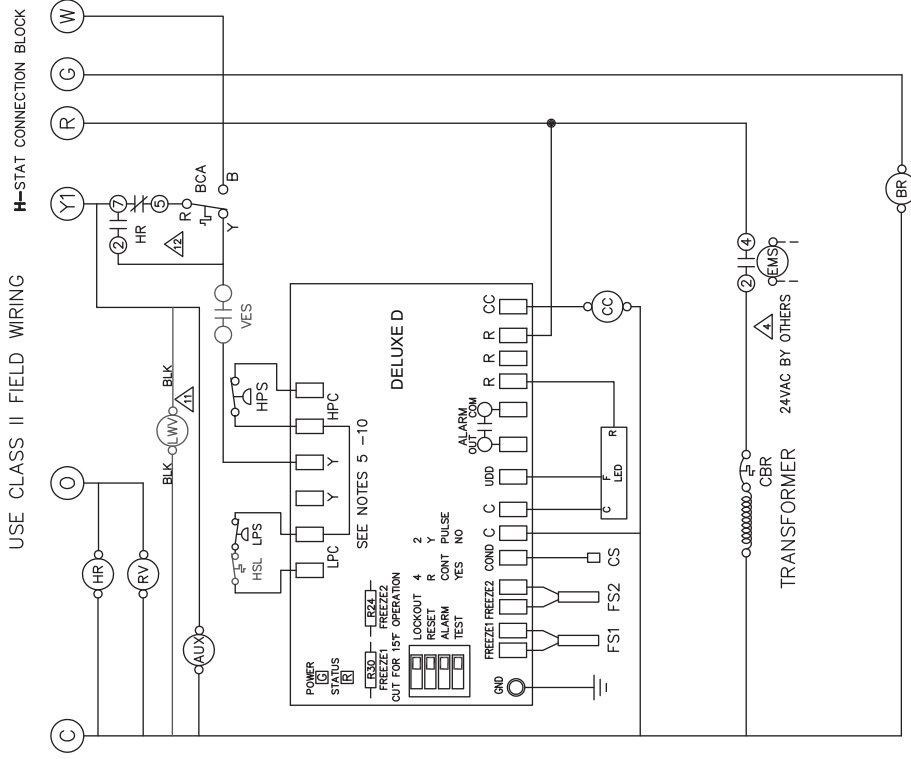

USE CLASS II FIELD WIRING

H-STAT CONNECTION BLOCK

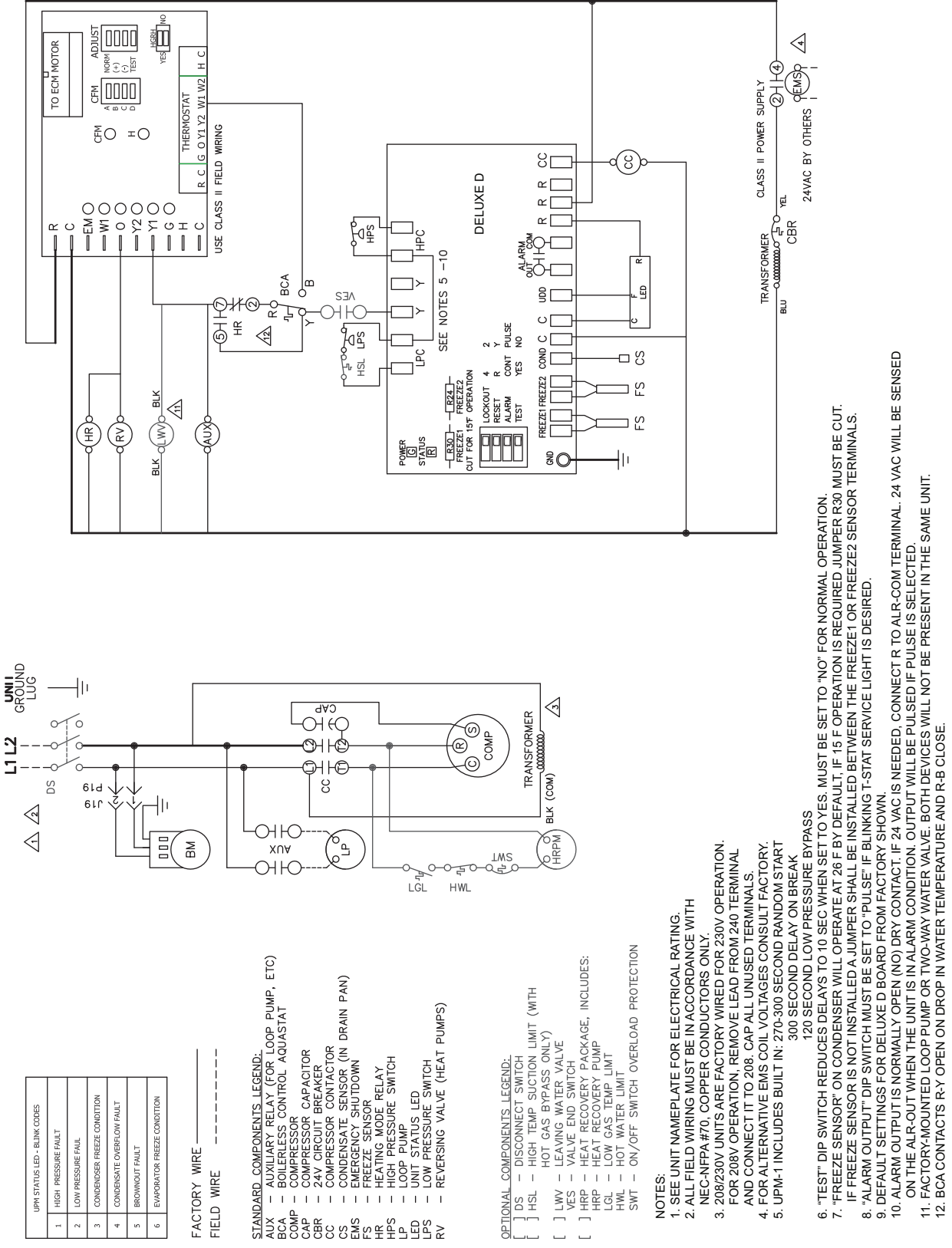

UPM STATUS LED - BLINK CODES	
1	HIGH PRESSURE FAULT
2	LOW PRESSURE FAULT
3	CONDENSER FREEZE CONDITION
4	CONDENSATE OVERFLOW FAULT
5	BROWNOUT FAULT
6	EVAPORATOR FREEZE CONDITION

FACTORY WIRE —————
 FIELD WIRE - - - - -

STANDARD COMPONENTS LEGEND:
 AUX - AUXILIARY RELAY (FOR LOOP PUMP, ETC)
 BCA - BOILERLESS CONTROL AQUASTAT
 COMP - COMPRESSOR
 CAP - COMPRESSOR CAPACITOR
 CBR - 24V CIRCUIT BREAKER
 CC - COMPRESSOR CONTACTOR
 CS - CONDENSATE SENSOR (IN DRAIN PAN)
 EMS - EMERGENCY SHUTDOWN
 FS - FREEZE SENSOR
 HR - HEATING MODE RELAY
 HPS - HIGH PRESSURE SWITCH
 LP - LOOP PUMP
 LED - UNIT STATUS LED
 LPS - LOW PRESSURE SWITCH
 RV - REVERSING VALVE (HEAT PUMPS)

OPTIONAL COMPONENTS LEGEND:
 [] DS - DISCONNECT SWITCH
 [] HSL - HIGH TEMP SUCTION LIMIT (WITH HOT GAS BYPASS ONLY)
 [] LWV - LEAVING WATER VALVE
 [] YES - VALVE END SWITCH
 [] HRP - HEAT RECOVERY PACKAGE, INCLUDES: HRP - HEAT RECOVERY PUMP
 LGL - LOW GAS TEMP LIMIT
 HWL - HOT WATER LIMIT
 SWT - ON/OFF SWITCH OVERLOAD PROTECTION

- NOTES:**
1. SEE UNIT NAMEPLATE FOR ELECTRICAL RATING.
 2. ALL FIELD WIRING MUST BE IN ACCORDANCE WITH NEC-NFPA #70, COPPER CONDUCTORS ONLY.
 3. 208/230V UNITS ARE FACTORY WIRED FOR 230V OPERATION. FOR 208V OPERATION, REMOVE LEAD FROM 240 TERMINAL AND CONNECT IT TO 208. CAP ALL UNUSED TERMINALS.
 4. FOR ALTERNATIVE EMS COIL VOLTAGES CONSULT FACTORY.
 5. UPM-1 INCLUDES BUILT IN: 270-300 SECOND RANDOM START
300 SECOND DELAY ON BREAK
120 SECOND LOW PRESSURE BYPASS
 6. "TEST" DIP SWITCH REDUCES DELAYS TO 10 SEC WHEN SET TO YES. MUST BE SET TO "NO" FOR NORMAL OPERATION.
 7. "FREEZE SENSOR" ON CONDENSER WILL OPERATE AT 26 F BY DEFAULT. IF 15 F OPERATION IS REQUIRED JUMPER R30 MUST BE CUT. IF FREEZE SENSOR IS NOT INSTALLED A JUMPER SHALL BE INSTALLED BETWEEN THE FREEZE1 OR FREEZE2 SENSOR TERMINALS.
 8. "ALARM OUTPUT" DIP SWITCH MUST BE SET TO "PULSE" IF BLINKING T-STAT SERVICE LIGHT IS DESIRED.
 9. DEFAULT SETTINGS FOR DELUXE D BOARD FROM FACTORY SHOWN.
 10. ALARM OUTPUT IS NORMALLY OPEN (NO) DRY CONTACT. IF 24 VAC IS NEEDED, CONNECT R TO ALR-COM TERMINAL. 24 VAC WILL BE SENSED ON THE ALR-OUT WHEN THE UNIT IS IN ALARM CONDITION. OUTPUT WILL BE PULSED IF PULSE IS SELECTED.
 11. FACTORY-MOUNTED LOOP PUMP OR TWO-WAY WATER VALVE. BOTH DEVICES WILL NOT BE PRESENT IN THE SAME UNIT.
 12. BCA CONTACTS R-Y OPEN ON DROP IN WATER TEMPERATURE AND R-B CLOSE.

Fig. 17 — EON Motor, Single Phase/Single Stage, Deluxe D Control

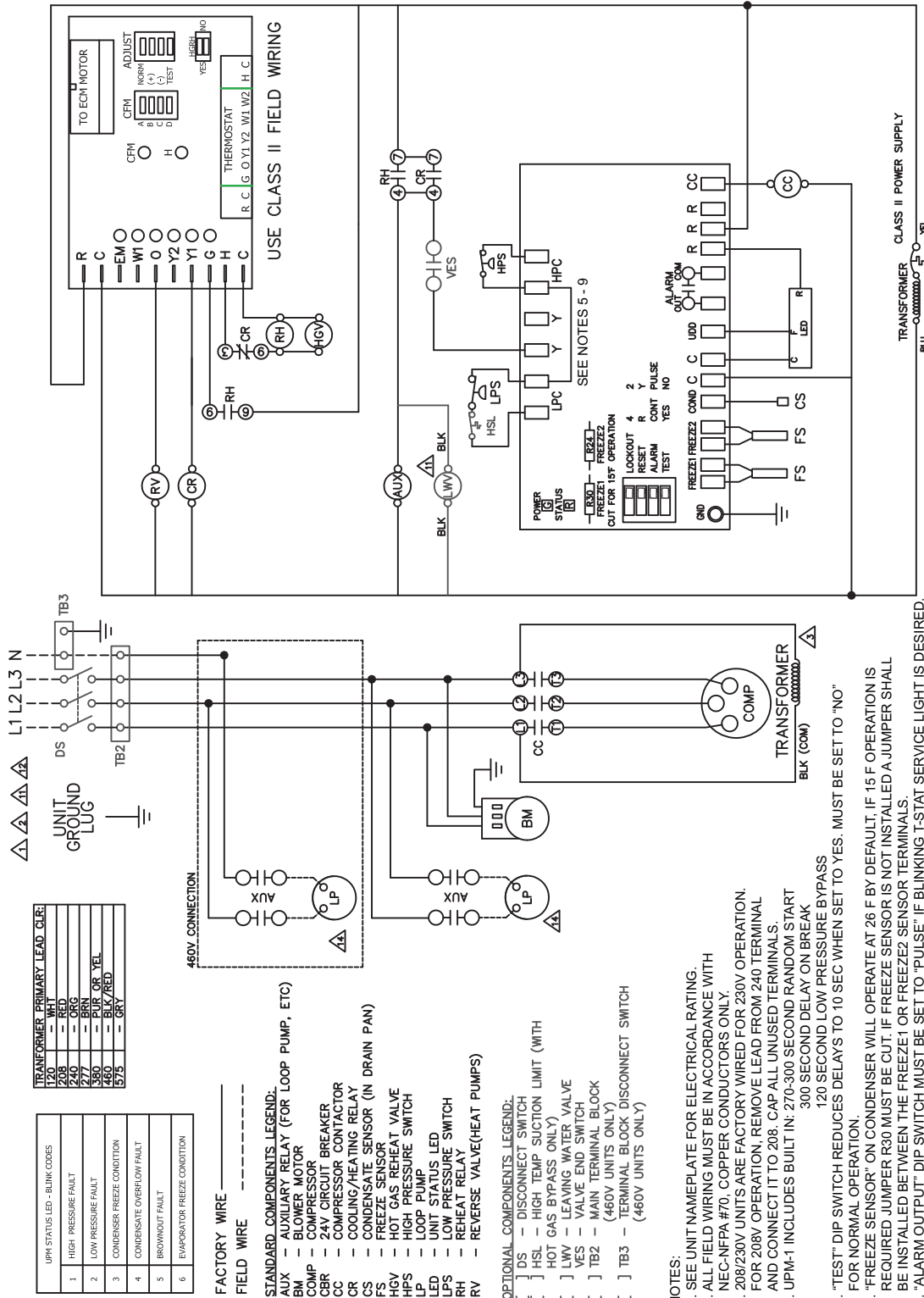

- UNIT STATUS LED - BLINK CODES**
- | | |
|---|-----------------------------|
| 1 | HIGH PRESSURE FAULT |
| 2 | LOW PRESSURE FAULT |
| 3 | CONDENSATE FREEZE CONDITION |
| 4 | CONDENSATE OVER/LOW FAULT |
| 5 | BROWNOUT FAULT |
| 6 | EVAPORATOR FREEZE CONDITION |
- TRANSFORMER PRIMARY LEAD CLR:**
- | | |
|-----|--------------|
| 176 | - WHT |
| 208 | - RED |
| 240 | - ORG |
| 277 | - BRN |
| 350 | - PUR OR YEL |
| 460 | - BLK/RED |
| 575 | - GRN |
- STANDARD COMPONENTS LEGEND:**
- AUX - AUXILIARY RELAY (FOR LOOP PUMP, ETC)
 - BM - BLOWER MOTOR
 - COMP - COMPRESSOR
 - CBR - 24V CIRCUIT BREAKER
 - CC - COMPRESSOR CONTACTOR
 - CR - COOLING/HEATING RELAY
 - CS - CONDENSATE SENSOR (IN DRAIN PAN)
 - FS - FREEZE SENSOR
 - HGV - HOT GAS REHEAT VALVE
 - HPS - HIGH PRESSURE SWITCH
 - LP - LOOP PUMP
 - LED - UNIT STATUS LED
 - LPS - LOW PRESSURE SWITCH
 - RH - REHEAT RELAY
 - RV - REVERSE VALVE(HEAT PUMPS)
- OPTIONAL COMPONENTS LEGEND:**
- [] DS - DISCONNECT SWITCH
 - [] HSL - HIGH TEMP SUCTION LIMIT (WITH HOT GAS BYPASS ONLY)
 - [] LWV - LEAVING WATER VALVE
 - [] VES - VALVE END SWITCH
 - [] TB2 - MAIN TERMINAL BLOCK (460V UNITS ONLY)
 - [] TB3 - TERMINAL BLOCK DISCONNECT SWITCH (460V UNITS ONLY)
- NOTES:**
- SEE UNIT NAMEPLATE FOR ELECTRICAL RATING.
 - ALL FIELD WIRING MUST BE IN ACCORDANCE WITH NEC-NFPA #70, COPPER CONDUCTORS ONLY.
 - 208/230V UNITS ARE FACTORY WIRED FOR 230V OPERATION. FOR 208V OPERATION, REMOVE LEAD FROM 240 TERMINAL AND CONNECT IT TO 208. CAP ALL UNUSED TERMINALS.
 - UPM-1 INCLUDES BUILT IN: 270-300 SECOND RANDOM START 300 SECOND DELAY ON BREAK 120 SECOND LOW PRESSURE BYPASS
 - "TEST" DIP SWITCH REDUCES DELAYS TO 10 SEC WHEN SET TO "YES. MUST BE SET TO "NO" FOR NORMAL OPERATION.
 - "FREEZE SENSOR" ON CONDENSER WILL OPERATE AT 26 F BY DEFAULT, IF 15 F OPERATION IS REQUIRED JUMPER R30 MUST BE CUT. IF FREEZE SENSOR IS NOT INSTALLED A JUMPER SHALL BE INSTALLED BETWEEN THE FREEZE1 OR FREEZE2 SENSOR TERMINALS.
 - "ALARM OUTPUT" DIP SWITCH MUST BE SET TO "PULSE" IF BLINKING T-STAT SERVICE LIGHT IS DESIRED.
 - DEFAULT SETTINGS FOR DELUXE D BOARD FROM FACTORY SHOWN.
 - ALARM OUTPUT IS NORMALLY OPEN (NO) DRY CONTACT. IF 24 VAC IS NEEDED, CONNECT R TO ALR-COM TERMINAL. 24 VAC WILL BE SENSED ON THE ALR-OUT WHEN THE UNIT IS IN ALARM CONDITION. OUTPUT WILL BE PULSED IF PULSE IS SELECTED.
 - TERMINAL BLOCK TB3 LOCATED INSIDE DISCONNECT SWITCH BOX.
 - CHECK FOR PROPER PHASE ROTATION ON UNITS WITH SCROLL COMPRESSORS. REVERSE ROTATION WILL DAMAGE THE COMPRESSOR AND VOID UNIT WARRANTY.
 - FACTORY-MOUNTED LOOP PUMP OR TWO-WAY WATER VALVE. BOTH DEVICES WILL NOT BE PRESENT IN THE SAME UNIT.
 - PUMP MOTOR IS WIRED BETWEEN LINE AND NEUTRAL FOR 380-460VAC UNITS. FOR 208/230VAC UNITS PUMP MOTOR IS WIRED BETWEEN LINES.

Fig. 18 — Constant Torque Motor, Three Phase/Single Stage, Deluxe D Control

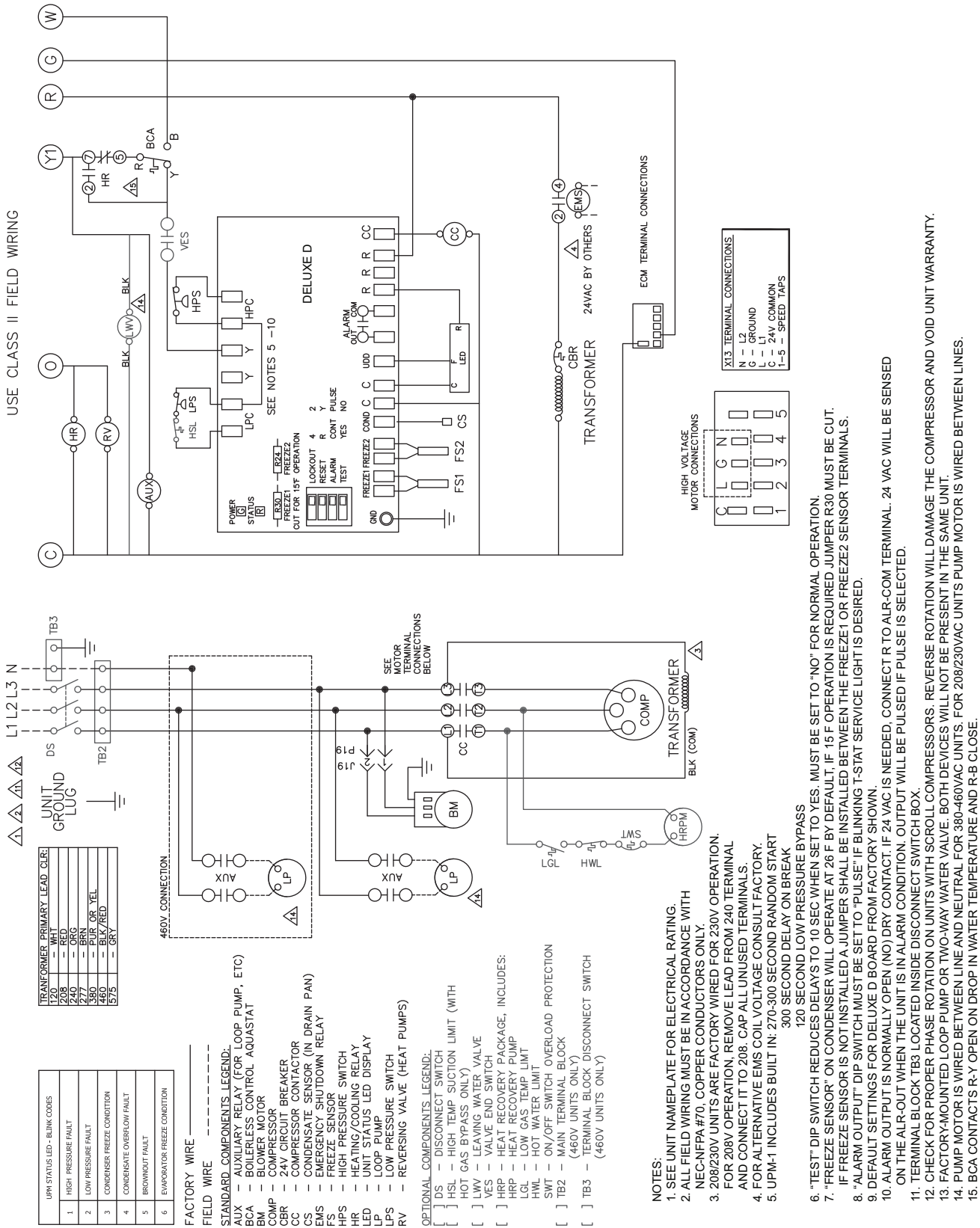

Fig. 19 — PSC Motor, Three Phase/Single Stage, Deluxe D Control

UPM STATUS LED - BLINK CODES
1. HIGH PRESSURE FAULT
2. LOW PRESSURE FAULT
3. CONDENSER FREEZE CONDITION
4. CONDENSATE OVERFLOW FAULT
5. BLOWOUT FAULT
6. EVAPORATOR FREEZE CONDITION

TRANSFORMER PRIMARY LEAD CODE	WIRE COLOR
120	WHI
208	RED
230V	BLK
240	GRY
360	BLU OR YEL
460	BLK/RED
575	GRY

- FACTORY WIRE** ———
- FIELD WIRE** - - - - -
- STANDARD COMPONENTS LEGEND:**
- AUX — AUXILIARY RELAY (FOR LOOP PUMP, ETC)
 - BCA — BOILERLESS CONTROL AQUASTAT
 - BC — BLOWER MOTOR CAPACITOR
 - BM — BLOWER MOTOR
 - BR — BLOWER RELAY
 - COMP — COMPRESSOR
 - CAP — COMPRESSOR CAPACITOR
 - CBR — 24V CIRCUIT BREAKER
 - CC — COMPRESSOR CONTACTOR
 - CS — CONDENSATE SENSOR (IN DRAIN PAN)
 - EMS — EMERGENCY SHUTDOWN RELAY
 - FS — FREEZE SENSOR
 - HPS — HIGH PRESSURE SWITCH
 - HR — HEATING/COOLING RELAY
 - HRC — HEAT RECOVERY PACKAGE, INCLUDES:
 - LED — UNIT STATUS LED DISPLAY
 - LP — LOOP PUMP
 - LPS — LOW PRESSURE SWITCH (HEAT PUMPS)
 - RV — REVERSING VALVE (HEAT PUMPS)

- OPTIONAL COMPONENTS LEGEND:**
- [] DS — DISCONNECT SWITCH
 - [] HSL — HIGH TEMP SUCTION LIMIT (WITH HOT GAS BYPASS VALVE)
 - [] LWV — LEAVING WATER VALVE
 - [] VES — VALVE END SWITCH
 - [] HRP — HEAT RECOVERY PACKAGE, INCLUDES:
 - [] HRP — HEAT RECOVERY PUMP
 - [] LGL — LOW GAS TEMP LIMIT
 - [] HWL — HOT WATER LIMIT
 - [] SWT — ON/OFF SMOKE/ITCH OVERLOAD PROTECTION
 - [] TB2 — MAIN TERMINAL BLOCK (460V UNITS ONLY)
 - [] TB3 — TERMINAL BLOCK DISCONNECT SWITCH (460V UNITS ONLY)

NOTES:

1. SEE UNIT NAMEPLATE FOR ELECTRICAL RATING.
2. ALL FIELD WIRING MUST BE IN ACCORDANCE WITH NEC-NFPA #70, COPPER CONDUCTORS ONLY.
3. 208/230V UNITS ARE FACTORY WIRED FOR 230V OPERATION. FOR 208V OPERATION, REMOVE LEAD FROM 240 TERMINAL AND CONNECT IT TO 208. CAP ALL UNUSED TERMINALS.
4. FOR ALTERNATIVE EMS COIL VOLTAGES CONSULT FACTORY.
5. UPM-1 INCLUDES BUILT IN: 2700-300 SECOND RANDOM START 300 SECOND DELAY ON BREAK 120 SECOND LOW PRESSURE BYPASS
6. "TEST" DIP SWITCH REDUCES DELAYS TO 10 SEC WHEN SET TO "NO". MUST BE SET TO "NO" FOR NORMAL OPERATION.
7. "FREEZE SENSOR" ON CONDENSER WILL OPERATE AT 26 F BY DEFAULT. IF 18 F OPERATION IS REQUIRED JUMPER R30 MUST BE CUT. IF FREEZE SENSOR IS NOT INSTALLED A JUMPER SHALL BE INSTALLED BETWEEN THE FREEZE1 OR FREEZE2 SENSOR TERMINALS.
8. "ALARM OUTPUT" DIP SWITCH MUST BE SET TO "PULSE" IF BLINKING T-STAT SERVICE LIGHT IS DESIRED.
9. DEFAULT SETTINGS FOR DELUXE D BOARD FROM FACTORY SHOWN
10. ALARM OUTPUT IS NORMALLY OPEN (NO) DRY CONTACT. IF 24 VAC IS NEEDED, CONNECT R TO ALR-COM TERMINAL. 24 VAC WILL BE SENSED ON THE ALR-OUT WHEN THE UNIT IS IN ALARM CONDITION. OUTPUT WILL BE PULSED IF PULSE IS SELECTED.
11. TERMINAL BLOCK TB3 LOCATED INSIDE DISCONNECT SWITCH BOX.
12. CHECK FOR PROPER PHASE ROTATION ON UNITS WITH SCROLL COMPRESSORS. REVERSE ROTATION WILL DAMAGE THE COMPRESSOR AND VOID UNIT WARRANTY.
13. FACTORY-MOUNTED LOOP PUMP OR TWO-WAY WATER VALVE. BOTH DEVICES WILL NOT BE PRESENT IN THE SAME UNIT.
14. PUMP MOTOR IS WIRED BETWEEN LINE AND NEUTRAL FOR 380-460VAC UNITS. FOR 208/230VAC UNITS PUMP MOTOR IS WIRED BETWEEN LINES.
15. 208/230V AND 460V BLOWER MOTORS HAVE THREE SPEED TAPS. 575 BLOWER MOTORS ARE SINGLE SPEED. FOR 460 BLOWER MOTORS WIRE BLACK AND ORANGE LEADS TOGETHER FOR MED OR LO SPEED OPERATION. CAP UNUSED LEADS.
16. BCA CONTACTS R-Y OPEN ON DROP IN WATER TEMPERATURE AND R-B CLOSE.

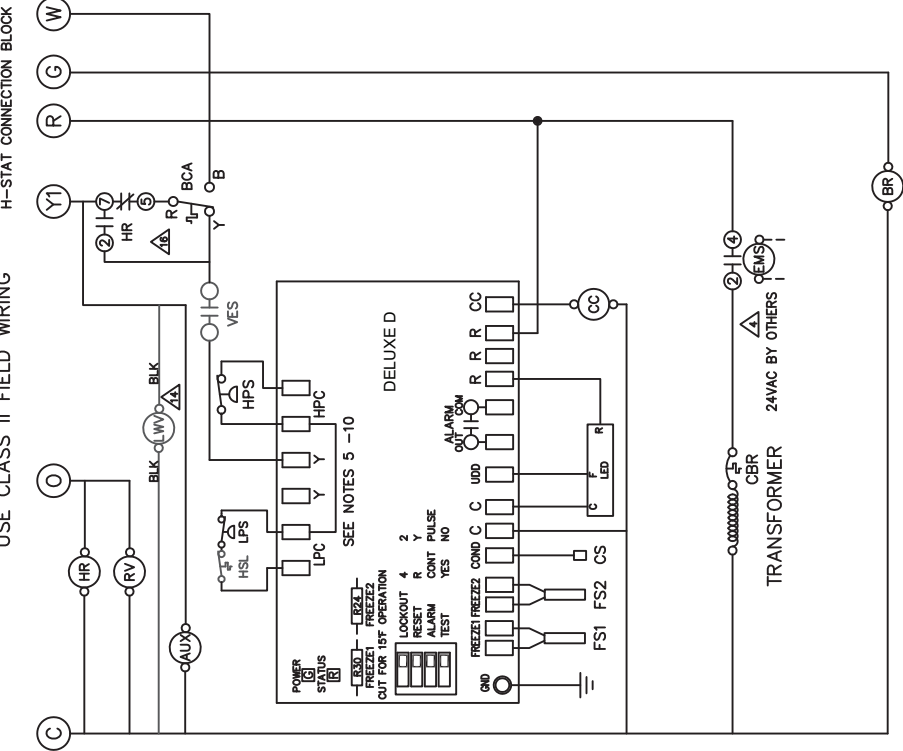
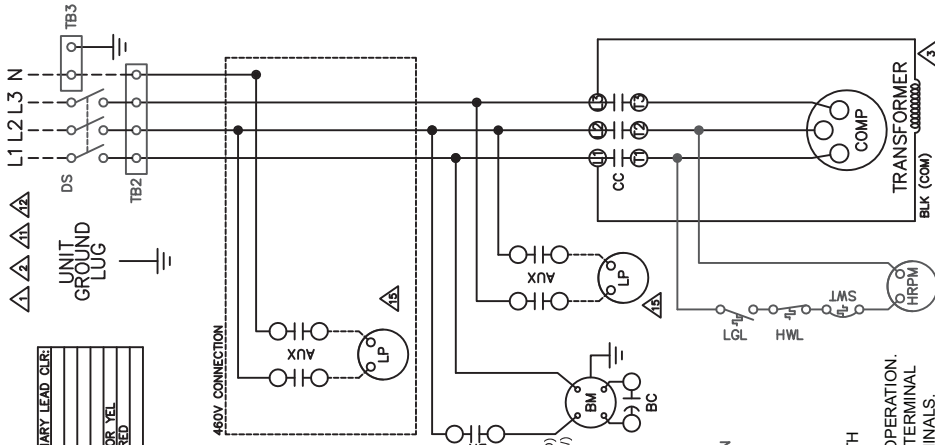

Fig. 20 — EON Motor, Three Phase/Single Stage, Deluxe D Control

Table 5 — Standard Motor — PSC for 007-012, Constant Torque for 015-070 Motor Electrical Data

50PS UNIT SIZE	RATED VOLTAGE v-ph-Hz	COMPRESSOR			BLOWER MOTOR			MIN. CIRCUIT AMP	MAX FUSE
		Qty	RLA	LRA	Qty	FLA	HP		
007	280/230-1-60	1	2.5	17.7	1	0.96	0.10	4.1	15
	265-1-60	1	2.6	13.5	1	0.85	0.10	4.1	15
009	208/230-1-60	1	3.4	22.2	1	0.96	0.10	5.2	15
	265-1-60	1	2.9	18.8	1	0.85	0.10	4.5	15
012	115-1-60	1	9.6	58.4	1	2.20	0.10	14.2	20
	208/230-1-60	1	4.6	27.9	1	0.96	0.10	6.7	15
	265-1-60	1	3.8	22.2	1	0.85	0.10	5.6	15
015	208/230-1-60	1	5.6	29.0	1	2.80	0.33	9.8	15
	265-1-60	1	4.6	20.0	1	2.60	0.33	8.4	15
018	208/230-1-60	1	7.4	33.0	1	2.80	0.33	12.1	15
	265-1-60	1	6.0	28.0	1	2.60	0.33	10.1	15
024	208/230-1-60	1	13.5	58.3	1	2.80	0.33	19.7	30
	265-1-60	1	9.0	54.0	1	2.60	0.33	13.9	20
	208/230-3-60	1	7.1	55.4	1	2.80	0.33	11.7	15
	460-3-60	1	3.5	28.0	1	2.10	0.50	6.5	15
030	208/230-1-60	1	12.8	58.3	1	4.10	0.50	20.1	30
	265-1-60	1	9.6	54.0	1	3.60	0.50	15.6	25
	208/230-3-60	1	7.7	55.4	1	2.80	0.50	12.4	20
	460-3-60	1	3.6	28.0	1	2.10	0.50	6.6	15
036	208/230-1-60	1	16.0	77.0	1	6.00	0.75	26.0	40
	208/230-3-60	1	10.0	71.0	1	6.00	0.75	18.5	25
	460-3-60	1	4.7	38.0	1	4.60	0.75	10.5	15
042	208/230-1-60	1	16.7	79.0	1	6.00	0.75	26.9	40
	208/230-3-60	1	10.4	73.0	1	6.00	0.75	19.0	25
	460-3-60	1	5.8	38.0	1	4.60	0.75	11.9	15
048	208/230-1-60	1	19.9	109.0	1	6.00	0.75	30.9	50
	208/230-3-60	1	13.6	83.1	1	6.00	0.75	23.0	35
	460-3-60	1	6.1	41.0	1	4.60	0.75	12.2	15
060	208/230-1-60	1	25.0	134.0	1	7.60	1.00	38.9	60
	208/230-3-60	1	15.9	110.0	1	7.60	1.00	27.5	40
	460-3-60	1	7.1	52.0	1	4.00	1.00	12.9	20
070	208/230-1-60	1	26.3	134.0	1	7.60	1.00	40.5	60
	208/230-3-60	1	15.6	110.0	1	7.60	1.00	27.1	40
	460-3-60	1	7.8	52.0	1	4.00	1.00	13.8	20

LEGEND

FLA — Full Load Amps
 LRA — Locked Rotor Amps
 RLA — Rated Load Amps

Table 6 — ECM Motor Electrical Data

50PS UNIT SIZE	RATED VOLTAGE v-ph-Hz	COMPRESSOR			BLOWER MOTOR			MIN. CIRCUIT AMP	MAX FUSE
		Qty	RLA	LRA	Qty	FLA	HP		
015	208/230-1-60	1	5.6	29.0	1	2.8	0.33	9.8	15
	265-1-60	1	4.6	20.0	1	2.6	0.33	8.4	15
018	208/230-1-60	1	7.4	33.0	1	2.8	0.33	12.1	15
	265-1-60	1	6.0	28.0	1	2.6	0.33	10.1	15
024	208/230-1-60	1	13.5	58.3	1	2.8	0.33	19.7	30
	265-1-60	1	9.0	54.0	1	2.6	0.33	13.9	20
	208/230-3-60	1	7.1	55.4	1	2.8	0.33	11.7	15
	460-3-60*	1	3.5	28.0	1	4.1	0.50	8.5	15
030	208/230-1-60	1	12.8	58.3	1	4.3	0.50	20.3	30
	265-1-60	1	9.6	54.0	1	4.1	0.50	16.1	25
	208/230-3-60	1	7.7	55.4	1	4.3	0.50	13.9	20
	460-3-60*	1	3.6	28.0	1	4.1	0.50	8.6	15
036	208/230-1-60	1	16.0	77.0	1	6.8	0.75	26.8	40
	208/230-3-60	1	10.0	71.0	1	6.8	0.75	19.3	25
	460-3-60*	1	4.7	38.0	1	5.5	0.75	11.4	15
042	208/230-1-60	1	16.7	79.0	1	6.8	0.75	27.7	40
	208/230-3-60	1	10.4	73.0	1	6.8	0.75	19.8	30
	460-3-60*	1	5.8	38.0	1	5.5	0.75	12.8	15
048	208/230-1-60	1	19.9	109.0	1	6.8	0.75	31.7	50
	208/230-3-60	1	13.6	83.1	1	6.8	0.75	23.8	35
	460-3-60*	1	6.1	41.0	1	5.5	0.75	13.1	15
060	208/230-1-60	1	25.0	134.0	1	9.1	1.00	40.4	60
	208/230-3-60	1	15.9	110.0	1	9.1	1.00	29.0	40
	460-3-60*	1	7.1	52.0	1	6.9	1.00	15.8	20
070	208/230-1-60	1	26.3	134.0	1	9.1	1.00	42.0	60
	208/230-3-60	1	15.6	110.0	1	9.1	1.00	28.6	40
	460-3-60*	1	7.8	52.0	1	6.9	1.00	16.7	20

LEGEND

FLA — Full Load Amps
LRA — Locked Rotor Amps
RLA — Rated Load Amps

* 460-v unit contains 265-v fan motor and requires a neutral to power motor.

Step 9 — Wire Field Controls

⚠ WARNING

To avoid possible injury or death due to electrical shock, open the power supply disconnect switch and secure it in an open position during installation.

⚠ CAUTION

Operating the unit with improper line voltage or with excessive phase imbalance is hazardous to the unit and constitutes abuse and is not covered under warranty.

All field wiring must comply with local and national fire, safety and electrical codes. Power to the unit must be within the operating voltage range indicated on the unit's nameplate. On three phase units, phases must be balanced within 2%.

Properly sized fuses or HACR circuit breakers must be installed for branch circuit protection. See equipment rating plates for proper size.

The heat pump units are provided with a concentric knock-out in the front right corner post for attaching common trade sizes of conduit. Route power supply wiring through this opening. Flexible wiring and conduit should be used to isolate vibration and noise from the building structure. Be certain to connect the ground lead to the ground lug in the control box. Connect the power leads as indicated on the unit wiring diagrams.

THERMOSTAT CONNECTIONS — Thermostat wiring is connected to a 7 position low voltage terminal block in the electrical box. The thermostat connections and their functions are as follows:

- Y** — Compressor Operation
- G** — Fan
- O** — Reversing Valve (energized in cooling)
- C** — Transformer 24 VAC Common – 3 Connections
- R** — Transformer 24 VAC Hot

If the unit is being connected to a thermostat with a malfunction light, this connection is made at the unit alarm output.

SAFETY DEVICES AND COMPLETE C CONTROLLER — Each unit is factory provided with a Complete C board controller that controls the compressor operation and monitors the safety.

IMPORTANT: If the thermostat is provided with a malfunction light powered off of the common (C) side of the transformer, a jumper between R and COM terminal of ALR contacts must be made.

IMPORTANT: If the thermostat is provided with a malfunction light powered off of the hot (R) side of the transformer, then the thermostat malfunction light connection should be connected directly to the (ALR) contact on the unit's Complete C board.

If the unit is being connected to a thermostat with a malfunction light, this connection is made at the unit malfunction output or relay. See to Fig. 21.

Safety controls include the following:

- High pressure switch located in the refrigerant discharge line and wired across the HPC terminals on the C Board
- Low pressure switch located in the unit refrigerant suction line and wired across terminals LPC1 and LPC2 on the C Board
- Complete C board dry contacts are normally open (NO)

Water side freeze protection sensor, mounted close to condensing water coil, monitors refrigerant temperature between condensing water coil and thermal expansion valve. If temperature drops below or remains at freeze limit trip for 30 seconds, the controller will shut down the compressor and enter into a soft lockout condition. The default freeze limit trip is 30 F, however this can be changed to 15 F by cutting the R30 or Freeze1 resistor located on top of DIP switch SW1. Refer to Fig. 21, item [3] for resistor location. If unit is employing a fresh water system (no anti-freeze protection), it is extremely important to have the Freeze1 R30 resistor set to 30 F in order to shut down the unit at the appropriate leaving water temperature and protect your heat pump from freezing if a freeze sensor is included.

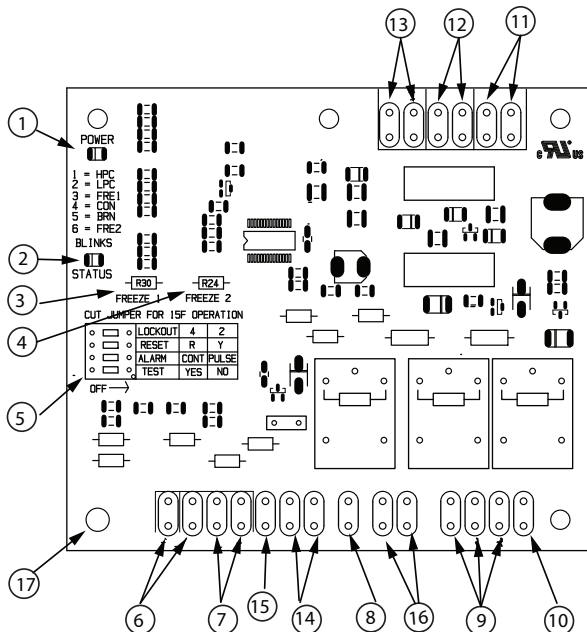

1	Board Power Indicator
2	C Board Status LED Indicator
3	Water Coil Freeze Protection Temperature Selection [R30]
4	Air Coil Freeze Protection Temperature Selection
5	C Board Settings
6	Water Coil Freeze Connection
7	Air Coil Freeze Connection
8	LED Status-Diagnostic Connection
9	24VAC Power Input
10	Compressor Contact Output
11	High Pressure Switch Connection
12	Call for Compressor Y1
13	Low Pressure Switch Connection
14	24VAC Power Common
15	Condensate Overflow Sensor
16	Dry Contact
17	C Board Ground Standoff

Fig. 21 — Complete C Control Board

- Evaporator freeze protection sensor, mounted between the thermal expansion device and the evaporator, monitors refrigerant temperature between the evaporator coil and thermal expansion valve. If temperature drops below or remains at freeze limit trip for 30 seconds, the controller will shut down the compressor and enter into a soft lockout condition. The default freeze limit trip is 30 F.
- The condensate overflow protection sensor is located in the drain pan of the unit and connected to the 'COND' terminal on the C board.

C BOARD FACTORY DEFAULT SETTINGS	
Temperature	30 F
Lockout	2
Reset	Y
Alarm	Pulse
Test	NO

C DIP SWITCH DEFAULT POSITION		
Lockout	4	2
Reset	R	Y
Alarm	Cont	Pulse
Test	Yes	No

IMPORTANT: If freeze protection sensor is not installed, a jumper between freeze contacts must be installed on the C board. Otherwise, unit will not start. See Fig. 22.

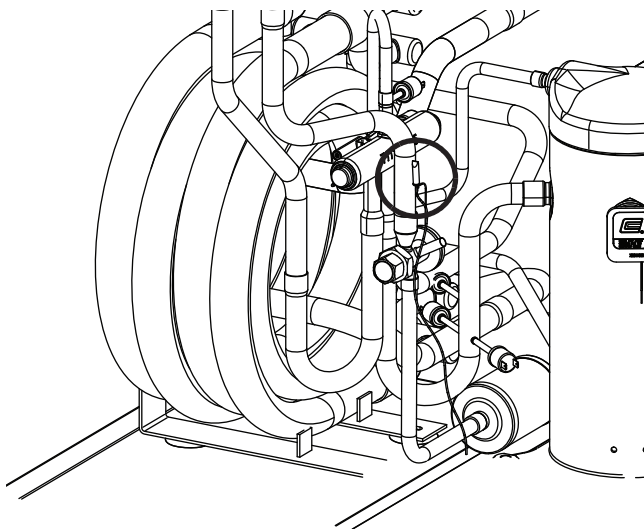

Fig. 22 — No Freeze Protection Sensor

The C Board includes the following features:

Anti-short Cycle Time — A 5-minute delay on break timer to prevent compressor short cycling.

Random Start — Each controller has a unique random start delay ranging from 270 to 300 seconds to reduce the chances of multiple units simultaneously starting after initial power up or after a power interruption, creating a large electrical spike.

Low Pressure Bypass Timer — If the compressor is running and the low-pressure switch opens, then the control will keep the compressor on for 120 seconds. After 2 minutes if the low-pressure switch remains open, the control will shut down the compressor and enter a soft lockout. The compressor will not be energized until the low-pressure switch closes and the anti-short cycle time delay expires. If the low-pressure switch opens 2 to 4 times in 1 hour, the unit will enter a hard lock out and need to be reset.

Brownout/surge/power Interruption Protection — The brownout protection in the C board will shut down the compressor if the incoming power falls below 18 VAC. The compressor will remain off until the voltage goes above 18 VAC and the anti short cycle timer (300 seconds) times out. The unit will not go into a hard lockout.

Malfunction Output — Alarm output is normally open (NO) dry contact. If 24 VAC output is needed R must be wired to the ALR-COM terminal; 24VAC will be available on the ALR-OUT terminal when the unit is in alarm condition. If pulse is selected the alarm output will be pulsed. The fault output will depend on the dip switch setting for ALARM. If it set to CONST, a constant signal will be produced to indicate a fault has occurred and the unit requires inspection to determine the type of fault. If it is set to PULSE, a pulse signal is produced and a fault code is detected by a remote device indicating the fault. See LED Fault Indication below for blink code explanations. The remote device must have a malfunction detection capability when the C board is set to PULSE.

Test DIP Switch — A test DIP switch is provided to reduce all time delay settings to 10 seconds during troubleshooting or verification of unit operation. Note that operation of the unit while in test mode can lead to accelerated wear and premature failure of the unit. The TEST switch must be set back to “NO” for normal operation.

Freeze Sensor — The default setting for the freeze limit trip is 30 F (sensor number 1); however this can be changed to 15 F by cutting the R30 resistor located on top of the DIP switch SW1. The default setting for the freeze limit trip is 30 F (sensor number 1); however this can be changed to 15 F by cutting the R24 resistor located on top of the DIP switch SW1. Since freeze sensor 2 is dedicated to monitor the evaporator coil it is recommended to leave the factory default setting on the board. The C board controller will constantly monitor the refrigerant temperature with the sensor mounted close to the condensing water coil between the thermal expansion valve and water coil. If temperature drops below or remains at the freeze limit trip for 30 seconds, the controller will shut the compressor down and enter into a soft lockout condition. Both the status LED and the Alarm contact will be active. The LED will flash three times with the code associated with this alarm condition. If this alarm occurs 2 times (or 4 if DIP switch is set to 4) within an hour, the C board controller will enter into a hard lockout condition. It will constantly monitor the refrigerant temperature with the sensor mounted close to the evaporator between the thermal expansion valve and evaporator coil. If temperature drops below or remains at the freeze limit trip for 30 seconds, the controller will shut the compressor down and enter into a soft lockout condition. Both the status LED and the Alarm contact will be active. The LED will flash six times the code associated with this alarm condition. If this alarm occurs 2 times (or 4 if DIP switch is set to 4) within an hour, the controller will enter into a hard lockout condition.

IMPORTANT: If unit is employing a fresh water system (no anti-freeze protection), it is extremely important to have the Freeze jumper R42 resistor set to 30 F in order to shut down the unit at the appropriate leaving water temperature and protect your heat pump from freezing if a freeze sensor is included.

Intelligent Reset — If a fault condition is initiated, the 5-minute delay on break time period is initiated and the unit will restart after these delays expire. During this period, the fault LED will indicate the cause of the fault. If the fault condition still exists or occurs 2 or 4 times (depending on 2 or 4 setting for Lockout dip switch) before 60 minutes, the unit will go into a hard lockout and requires a manual lockout reset. A single condensate overflow fault will cause the unit to go into a hard lockout immediately, and will require a manual lockout reset.

Lockout Reset — A hard lockout can be reset by turning the unit thermostat off and then back on when the “RESET” dip switch is set to “Y” or by shutting off unit power at the circuit breaker when the “RESET” dip switch is set to “R”. The blower motor will remain active during a lockout condition.

CONSIDERATIONS

1. Always check incoming line voltage power supply and secondary control voltage for adequacy. Transformer primaries are dual tapped for 208 and 230 volts. Connect the appropriate tap to ensure a minimum of 18 volts secondary control voltage. 24 volts is ideal for best operation.
2. Long length thermostat and control wiring leads may create voltage drop. Increase wire gauge or up-size transformers may be required to ensure minimum secondary voltage supply.
3. The following guidelines are recommended for wiring between a thermostat and the unit: 18 GA up to 60 foot, 16 GA up to 100 ft and 14 GA up to 140 ft.
4. Do not apply additional controlled devices to the control circuit power supply without consulting the factory. Doing so may void equipment warranties.
5. Check with all code authorities on requirements involving condensate disposal/over flow protection criteria.

Operate ECM Interface Board — In addition to providing a connecting point for thermostat wiring, the interface board also translates thermostat inputs into control commands for the Electronic Commutated Motor (ECM) DC fan motor

and provides thermostat signals to unit’s Complete C control. The thermostat connections and their functions are shown in Fig. 23.

IMPORTANT: CFM LED is an approximation. Utilize conventional Test and Balance equipment for accurate airflow measurement.

CFM count indicator (See Fig. 24, item 6) blinks to indicate approximate airflow in CFM and may flicker when unit is off. Each blink of the LED represents approximately 100 CFM of air delivery, so if the LED blinks 12 times, pauses, blinks 12 times, etc. the blower is delivering approximately 1200 CFM.

THERMOSTAT OUTPUTS

- Y1** First Stage Compressor Operation
- Y2** Second Stage Compressor Operation
- G** Fan
- O** Reversing Valve (energized in cooling)
- W1** Auxiliary Electric Heat (runs with compressor)
- EM/W2** Emergency Heat (electric heat only)
- NC** Transformer 24 VAC Common (extra connection)
- C1** Transformer 24 VAC Common (primary connection)
- R** Transformer 24 VAC Hot
- H** Dehumidification Mode

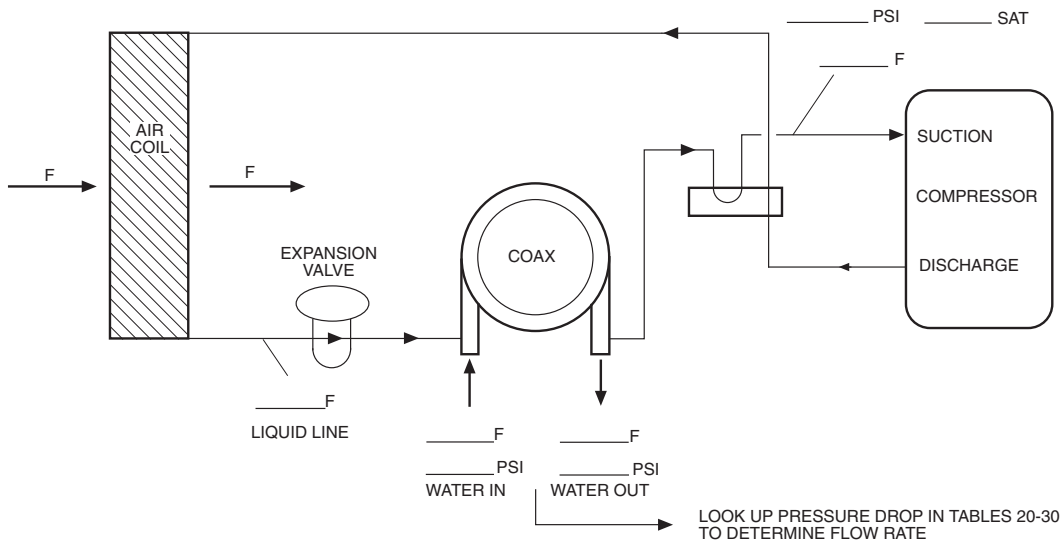
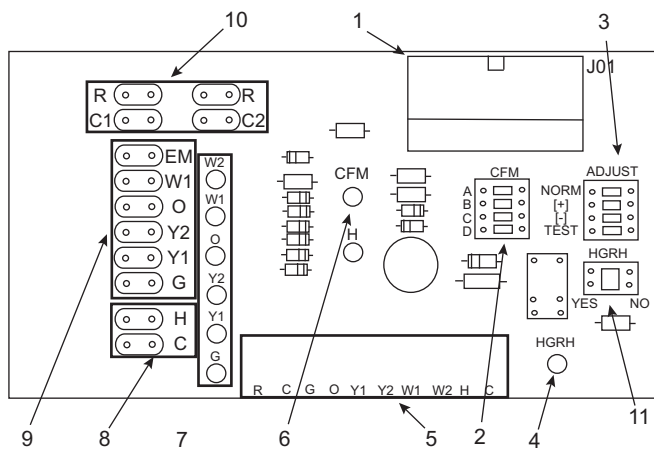

Fig. 23 — Low Voltage Field Wiring



1	Motor harness plug
2	Blower CFM adjustment
3	Motor settings
4	Dehumidification indication
5	Thermostat digital contact inputs
6	CFM count indicator
7	Thermostat input status indication
8	Reheat digital outputs
9	Thermostat outputs
10	24 VAC
11	Dehumidification method selector

Fig. 24 — ECM Interface Board Physical Layout

NOTE: Power must be off to the unit for at least three seconds before the ECM will recognize a speed change. The motor will recognize a change in the CFM adjust or Dehumidification mode settings while the unit is powered.

There are three different airflow settings from lowest airflow rate (speed tap 1) to the highest airflow rate (speed tap 4).

CAUTION

When the disconnect switch is closed, high voltage is present in some areas of the electrical panel. Exercise caution when working with energized equipment. Failure to heed this safety precaution could lead to personal injury.

COOLING — The cooling setting determines the cooling (normal) cfm for all units with ECM motor. Cooling (normal) setting is used when the unit is not in Dehumidification mode. Tap 1 is the lowest cfm setting, while tap 4 is the highest cfm setting. To avoid air coil freeze-up, tap 1 may not be used if the Dehumidification mode is selected.

HEATING — The heating setting determines the heating cfm for 50PSH, PSV units. Tap 1 is the lowest cfm setting, while tap 4 is the highest cfm setting.

CFM ADJUST — The CFM Adjust setting allows four selections. The NORM setting is the factory default position. The + or – settings adjust the airflow by ±15%. The + or – settings are used to “fine tune” airflow adjustments. The TEST setting runs the ECM at 70% torque, which causes the motor to operate like a standard PSC motor, and disables the cfm counter.

DEHUMIDIFICATION MODE — The dehumidification mode setting provides field selection of humidity control. When operating in the normal mode, the cooling airflow settings are determined by the cooling tap setting. When dehumidification is enabled, there is a reduction in airflow in cooling to increase the moisture removal of the heat pump. The Dehumidification mode can be enabled in two ways:

1. Constant Dehumidification mode: When the Dehumidification mode is selected via DIP switch, the ECM will operate with a multiplier applied to the cooling CFM settings (approximately 20 to 25% lower airflow). Any time the unit is running in the Cooling mode, it will operate at the lower airflow to improve latent capacity. The “DEHUM” LED will be illuminated at all times. Heating airflow is not affected.

NOTE: Do not select Dehumidification mode if cooling setting is tap 1.

2. Automatic (humidistat-controlled) Dehumidification mode: When the Dehumidification mode is selected via DIP switch AND a humidistat is connected to terminal DH, the cooling airflow will only be reduced when the humidistat senses that additional dehumidification is required. The DH terminal is reverse logic. Therefore, a humidistat (not dehumidistat) is required. The “DEHUM” LED will be illuminated only when the humidistat is calling for Dehumidification mode. Heating airflow is not affected.

NOTE: Do not select Dehumidification mode if cooling setting is tap 1.

PRE-START-UP

System Checkout — After completing the installation and before energizing the unit, the following system checks should be made prior to initial startup:

1. Verify that the supply voltage to the heat pump is in accordance with the nameplate ratings.
2. Make sure that all electrical connections are tight and secure.
3. Check the electrical fusing and wiring for the correct size.
4. Verify that the low voltage wiring between the thermostat and the unit is correct.
5. Verify that the water piping is complete and correct.
6. Check that the water flow is correct, and adjust if necessary.
7. Check the blower for free rotation, and that it is secured to the shaft.
8. Verify that vibration isolation has been provided.
9. Unit is serviceable. Be certain that all access panels are secured in place.
10. Verify that the blower support has been removed.
11. Verify that ductwork has been properly fastened to supply and return duct collars.
12. Make sure return air filters are positioned correctly in the filter rack if removed during installation.

AIR COIL — To obtain maximum performance, clean the air coil before starting the unit. A 10% solution of dishwasher detergent and water is recommended for both sides of the coil. Rinse thoroughly with water.

START-UP

Use the procedure outlined below to initiate proper unit start-up.

NOTE: This equipment is designed for indoor installation only. Set the thermostat to the highest setting.

Operating Limits

ENVIRONMENT — This equipment is designed for indoor installation only. Extreme variations in temperature, humidity and corrosive water or air will adversely affect the unit performance, reliability and service life.

POWER SUPPLY — A voltage variation of $\pm 10\%$ of nameplate utilization voltage is acceptable.

UNIT STARTING CONDITIONS — Units start and operate in an ambient temperature of 45 F with entering-air temperature at 50 F, entering-water temperature at 60 F and with both air and water at the flow rates used.

NOTE: These operating limits are not normal or continuous operating conditions. Assume that such a start-up is for the purpose of bringing the building space up to occupancy temperature. See Table 7 for operating limits.

WARNING

When the disconnect switch is closed, high voltage is present in some areas of the electrical panel. Exercise caution when working with the energized equipment. Failure to heed this warning may result in personal injury.

1. Restore power to system.
2. Turn thermostat fan position to ON. Blower should start.
3. Balance airflow at registers.
4. Adjust all valves to the full open position and turn on the line power to all heat pump units.
5. Operate unit in the cooling cycle. Refer to Table 7 for unit operating limits.

NOTE: Three factors determine the operating limits of a unit: (1) entering air temperature, (2) water temperature and (3) ambient temperature. Whenever any of these factors are at a minimum or maximum level, the other two factors must be at a normal level to ensure proper unit operation.

Table 7 — Operating Limits

AIR LIMITS	STANDARD UNIT	EXTENDED RANGE OPTION
COOLING		
Minimum ambient air temperature F	50	50
Maximum ambient air temperature F	100	100
Minimum evaporator entering air db/wb F	68/57	68/57
Rated air coil entering air db/wb F	80/67	80/67
Maximum evaporator entering air db/wb F	95/85	98/85
Minimum water coil entering fluid temperature F	50	50
Water loop typical coil entering fluid range temperature F	70/90	70/90
Maximum water coil entering fluid temperature F	110	110
HEATING		
Minimum ambient air temperature F	50	40
Maximum ambient air temperature F	100	85
Minimum evaporator entering air db F	50	50
Rated air coil entering air F	68	68
Maximum evaporator entering air db F	80	80
Normal water coil entering fluid range F	50-80	25-80*
Minimum water coil entering Fluid F	50	20*

LEGEND

db — Dry Bulb
wb — Wet Bulb

*Antifreeze solution is required at these fluid temperatures.

Scroll Compressor Rotation — It is important to be certain the compressor is rotating in the proper direction. To determine whether or not the compressor is rotating in the proper direction:

1. Connect service gages to suction and discharge pressure fittings.
2. Energize the compressor.
3. The suction pressure should drop and the discharge pressure should rise, as is normal on any start-up.

If the suction pressure does not drop and the discharge pressure does not rise to normal levels:

1. Turn off power to the unit. Install disconnect tag.
2. Reverse any two of the unit power leads.
3. Reapply power to the unit and verify pressures are correct.

The suction and discharge pressure levels should now move to their normal start-up levels.

When the compressor is rotating in the wrong direction, the unit makes more noise and does not provide cooling.

After a few minutes of reverse operation, the scroll compressor internal overload protection will open, thus activating the unit lockout. This requires a manual reset. To reset, turn the thermostat on and then off.

NOTE: There is a 5-minute time delay before the compressor will start.

Unit Start-Up Cooling Mode

1. Adjust the unit thermostat to the warmest position. Slowly reduce the thermostat position until the compressor activates.
2. Check for cool air delivery at unit grille a few minutes after the unit has begun to operate.
3. Verify that the compressor is on and that the water flow rate is correct by measuring pressure drop through the heat exchanger using P/T plugs. See Table 8. Check the elevation and cleanliness of the condensate lines; any dripping could be a sign of a blocked line. Be sure the condensate trap includes a water seal.
4. Check the temperature of both supply and discharge water. If temperature is within range, proceed. If temperature is outside the range, check the cooling refrigerant pressures. Contact Carrier Commercial Services or product management for acceptable temperature ranges.
5. Check air temperature drop across the coil when compressor is operating. Air temperature drop should be between 15 and 25 F.

Table 8 — Water Temperature Change through Heat Exchanger

WATER FLOW RATE (GPM)	COOLING RISE (F)		HEATING DROP (F)	
	Min	Max	Min	Max
For Closed Loop: Ground Source or Cooling/Boiler Systems at 3 gpm/ton	9	12	4	8
For Open Loop: Ground Water Systems at 1.5 gpm/ton	20	26	10	17

Unit Start-Up Heating Mode

NOTE: Operate the unit in heating cycle after checking the cooling cycle. Allow 5 minutes between tests for the pressure or reversing valve to equalize.

1. Turn thermostat to lowest setting and set thermostat switch to HEAT position.
2. Slowly turn the thermostat to a higher temperature until the compressor activates.
3. Check for warm air delivery at the unit grille within a few minutes after the unit has begun to operate.
4. Check the temperature of both supply and discharge water. If temperature is within range, proceed. If temperature is outside the range, check the heating refrigerant

pressures. Contact Carrier Commercial Services or product management for acceptable temperature ranges.

5. Once the unit has begun to run, check for warm air delivery at the unit grille.
6. Check air temperature rise across the coil when compressor is operating. Air temperature rise should be between 20 and 30 F after 15 minutes at load.
7. Check for vibration, noise and water leaks.

Flow Regulation — Flow regulation can be accomplished by two methods. Most water control valves have a flow adjustment built into the valve. By measuring the pressure drop through the unit heat exchanger, the flow rate can be determined. Adjust the water control valve until the flow of 1.5 to 2 gpm is achieved. Since the pressure constantly varies, two pressure gages may be needed in some applications.

An alternative method is to install a flow control device. These devices are typically an orifice of plastic material designed to allow a specified flow rate that are mounted on the outlet of the water control valve. Occasionally these valves produce a velocity noise that can be reduced by applying some back pressure. To accomplish this, slightly close the leaving isolation valve of the well water setup.

⚠ WARNING

To avoid possible injury or death due to electrical shock, open the power supply disconnect switch and secure it in an open position before flushing system.

Flushing — Once the piping is complete, units require final purging and loop charging. A flush cart pump of at least 1.5 hp is needed to achieve adequate flow velocity in the loop to purge air and dirt particles from the loop. Flush the loop in both directions with a high volume of water at a high velocity. Follow the steps below to properly flush the loop:

1. Verify power is off.
2. Fill loop with water from hose through flush cart before using flush cart pump to ensure an even fill. Do not allow the water level in the flush cart tank to drop below the pump inlet line in order to prevent air from filling the line.
3. Maintain a fluid level in the tank above the return tee in order to avoid air entering back into the fluid.
4. Shutting off the return valve that connects into the flush cart reservoir will allow 50 psig surges to help purge air pockets. This maintains the pump at 50 psig.
5. To purge, keep the pump at 50 psig until maximum pumping pressure is reached.
6. Open the return valve to send a pressure surge through the loop to purge any air pockets in the piping system.
7. A noticeable drop in fluid level will be seen in the flush cart tank. This is the only indication of air in the loop.

NOTE: If air is purged from the system while using a 10 in. PVC flush tank, the level drop will only be 1 to 2 in. since liquids are incompressible. If the level drops more than this, flushing should continue since air is still being compressed in the loop. If level is less than 1 to 2 in., reverse the flow.

8. Repeat this procedure until all air is purged.
9. Restore power.

Antifreeze may be added before, during, or after the flushing process. However, depending on when it is added in the process, it can be wasted. Refer to the Antifreeze section for more detail.

Loop static pressure will fluctuate with the seasons. Pressures will be higher in the winter months than during the warmer months. This fluctuation is normal and should be considered when charging the system initially. Run the unit in either

heating or cooling for several minutes to condition the loop to a homogenous temperature.

When complete, perform a final flush and pressurize the loop to a static pressure of 40 to 50 psig for winter months or 15 to 20 psig for summer months.

After pressurization, be sure to remove the plug from the end of the loop pump motor(s) to allow trapped air to be discharged and to ensure the motor housing has been flooded. Be sure the loop flow center provides adequate flow through the unit by checking pressure drop across the heat exchanger.

Antifreeze — In areas where entering loop temperatures drop below 40 F or where piping will be routed through areas subject to freezing, antifreeze is needed.

Alcohols and glycols are commonly used as antifreeze agents. Freeze protection should be maintained to 15 F below the lowest expected entering loop temperature. For example, if the lowest expected entering loop temperature is 30 F, the leaving loop temperature would be 22 to 25 F. Therefore, the freeze protection should be at 15 F (30 F – 15 F = 15 F).

IMPORTANT: All alcohols should be pre-mixed and pumped from a reservoir outside of the building or introduced under water level to prevent fuming.

Calculate the total volume of fluid in the piping system. See Table 9. Use the percentage by volume in Table 10 to determine the amount of antifreeze to use. Antifreeze concentration should be checked from a well-mixed sample using a hydrometer to measure specific gravity.

FREEZE PROTECTION SELECTION — The 30 F FP1 factory setting (water) should be used to avoid freeze damage to the unit.

Once antifreeze is selected, the JW3 jumper (FP1) should be clipped on the control to select the low temperature (antifreeze 13 F) set point to avoid nuisance faults.

Table 9 — Approximate Fluid Volume (gal.) per 100 Ft of Pipe

PIPE	DIAMETER (in.)	VOLUME (gal.)
Copper	1	4.1
	1.25	6.4
	1.5	9.2
Rubber Hose	1	3.9
Polyethylene	3/4 IPS SDR11	2.8
	1 IPS SDR11	4.5
	1 1/4 IPS SDR11	8.0
	1 1/2 IPS SDR11	10.9
	2 IPS SDR11	18.0
	1 1/4 IPS SCH40	8.3
	1 1/2 IPS SCH40	10.9
2 IPS SCH40	17.0	

LEGEND

- IPS** — Internal Pipe Size
- SCH** — Schedule
- SDR** — Standard Dimensional Ratio

NOTE: Volume of heat exchanger is approximately 1.0 gallon.

Table 10 — Antifreeze Percentages by Volume

ANTIFREEZE	MINIMUM TEMPERATURE FOR FREEZE PROTECTION (F)			
	10	15	20	25
Methanol (%)	25	21	16	10
100% USP Food Grade Propylene Glycol (%)	38	30	22	15
Ethanol (%)	29	25	20	14

Cooling Tower/Boiler Systems — These systems typically use a common loop temperature maintained at 50 to 100 F. Carrier recommends using a closed circuit evaporative cooling tower with a secondary heat exchanger between the tower and the water loop. If an open type cooling tower is used continuously, chemical treatment and filtering will be necessary.

Ground Coupled, Closed Loop and Plateframe Heat Exchanger Well Systems — These systems allow water temperatures from 25 to 110 F. The external loop field is divided up into 2 in. polyethylene supply and return lines. Each line has valves connected in such a way that upon system start-up, each line can be isolated for flushing using only the system pumps. Locate air separation in the piping system prior to the fluid re-entering the loop field.

OPERATION

Cooling Mode — When the thermostat calls for cooling (Y), the loop pump or solenoid valve if present is energized and compressor will start. Once the thermostat is satisfied, the compressor shuts down accordingly and the fan ramps down to either fan only mode or off over a span of 30 seconds (ECM Motors).

NOTE: A fault condition initiating a lockout will de-energize the compressor.

Heating Mode — Heating operates in the same manner as cooling, but with the reversing valve de-energized. The compressor will run until the desired setpoint temperature on the thermostat is achieved. Once the thermostat is satisfied, the compressor shuts down and the fan ramps down in either fan only mode or turns off over a span of 30 seconds.

Power Up Mode — The unit will not operate until all the inputs, terminals and safety controls are checked for normal operation.

NOTE: The compressor will have a 5-minute anti-short cycle upon power up.

Units with Aquazone™ Complete C Control

STANDBY — Y and W terminals are not active in Standby mode. However, the O and G terminals may be active, depending on the application. The compressor will be off.

COOLING — Y and O terminals are active in Cooling mode. After power up, the first call to the compressor will initiate a 270 to 300 second random start delay and a 5-minute anti-short cycle protection time delay. After both delays are complete, the compressor is energized.

NOTE: On all subsequent compressor calls the random start delay is omitted.

HEATING STAGE 1 — Terminal Y is active in heating stage 1. After power up, the first call to the compressor will initiate a 270 to 300 second random start delay and a 5-minute anti-short cycle protection time delay. After both delays are complete, the compressor is energized.

NOTE: On all subsequent compressor calls the random start delay is omitted.

HEATING STAGE 2 — To enter Stage 2 mode (units equipped with 2 step compressor or with two compressors only), terminal Y2 is active (Y is already active). Also, the G terminal must be active or the W terminal is disregarded. The compressor relay will remain on and EH1 is immediately turned on. EH2 will turn on after 10 minutes of continual stage 2 demand.

LOCKOUT MODE — The status LED will flash fast in Lockout mode and the compressor relay will be turned off immediately. Lockout mode can be “soft” reset via the Y input or can be reset via the disconnect depending on the DIP switch settings. The last fault causing the lockout is stored in memory and can be viewed by entering test mode.

LOCKOUT WITH EMERGENCY HEAT — While in Lockout mode, if W becomes active, then Emergency Heat mode will occur.

EMERGENCY HEAT — In Emergency Heat mode, terminal W is active while terminal Y is not. Terminal G must be active

in the 50PS units the fan will be run if W is energized. EH1 is immediately turned on. EH2 will turn on.

Units with Aquazone Deluxe D Control

STANDBY/FAN ONLY — The compressor will be off. The Fan Enable, Fan Speed, and reversing valve (RV) relays will be on if inputs are present.

NOTE: DIP switch 5 on S1 does not have an effect upon Fan 1 and Fan 2 outputs.

HEATING STAGE 1 — In Heating Stage 1 mode, the Fan Enable and Compressor relays are turned on immediately. Once the demand is removed, the relays are turned off and the control reverts to Standby mode.

EMERGENCY HEAT — In Emergency Heat mode, the Fan Enable and Fan Speed relays are turned on. The EH1 output is turned on immediately.

COOLING STAGE 2 — In Cooling Stage 2 mode, the Fan Enable, compressor and RV relays remain on. The Fan Speed relay is turned on immediately and turned off immediately once the Cooling Stage 2 demand is removed. The control reverts to Cooling Stage 1 when the thermostat removes all Y2 call.

Units with Hot Gas Reheat Option

FAN ONLY — A (G) call from the thermostat to the (G) terminal of the Deluxe D control board will bring the unit on in fan only mode.

COOLING STAGE 1 — A simultaneous call from (G), (Y1), and (O) to the (G), (Y1) will bring the unit on in Cooling Stage 1.

COOLING STAGE 2 — A simultaneous call from (G), (Y1), (Y2), and (O) to the (G) will bring the unit on in Cooling Stage 2. When the call is satisfied at the thermostat the unit will continue to run in Cooling Stage 1 until the 49 Cooling Stage 1 call is removed or satisfied, shutting down the unit.

NOTE: Not all units have two-stage cooling functionality.

HEATING STAGE 1 — A simultaneous call from (G) and (Y1) to the (G) and (Y1) terminals will bring the unit on in Heating Stage 1.

HEATING STAGE 2 — A simultaneous call from (G), (Y1), and (Y2) will bring the unit on in Heating Stage 2. When the call is satisfied at the thermostat the unit will continue to run in Heating Stage 1 until the call is removed or satisfied, shutting down the unit.

NOTE: Not all units have two-stage heating functionality.

REHEAT MODE — A call from the humidistat/dehumidistat to the (H) terminal will bring the unit on in Reheat mode if there is no call for cooling at the thermostat. When the humidistat/dehumidistat call is removed or satisfied the unit will shut down.

NOTE: Cooling always overrides Reheat mode. In the Cooling mode, the unit cools and dehumidifies. If the cooling thermostat is satisfied but there is still a call for dehumidification, the unit will continue to operate in Reheat mode.

Sequence of Operation - On/Off Control — The sequence of operation in the cooling and heating mode is the same as a regular heat pump. In the reheat mode on a call from the humidistat the reheat relay coil is energized through the “H” circuit. The blower relay, reversing valve and compressor contactor are energized through the contacts of the reheat relay. See typical wiring diagrams at the end of the manual. The cooling relay remains deenergized enabling the reheat solenoid.

NOTE: The reheat mode always operates in the cooling mode.

Should the temperature in the space increase above set point the compressor terminal Y is energized which will de-energize the reheat valve putting the unit into the straight cooling mode.

A call for cooling or heating will always take precedence over hot gas reheat.

COMPLETE C AND DELUXE D BOARD SYSTEM TEST

Test mode provides the ability to check the control operation in a timely manner. The control enters a 20-minute test mode by momentarily shorting the test terminals. All time delays are sped up 15 times. The follow operations are common to both Complete C and Deluxe D controls.

Retry Mode — In Retry mode, the status LED will flash the code for the corresponding fault. If the fault clears and the thermostat call (Y) is still present the Complete C or Deluxe D control will run the compressor once the ASC (anti-short cycle) timer has expired and will try to satisfy the call. If the call is satisfied, the unit will resume its normal operation.

If 2 or 4 consecutive faults occur (depending on the DIP switch setting) within 1 hour, the controller will lock the compressor operation out and will flash the alarm code on the status LED as well as alarm dry contact output. When the Complete C or Deluxe D control enters lockout mode, the alarm will also be shown on the panel mounted LED.

LED Fault Indication — Two LED indicators are provided. The GREEN power LED indicates 18-30 VAC present at the board.

The RED LED is a fault indicator with blink codes as follows:

- One Blink = High pressure lockout
- Two Blinks = Low pressure lockout
- Three Blinks = Freeze sensor lockout
- Four Blinks = Condensate overflow
- Five Blinks = Brownout

Complete C Board Default Settings — The Complete C board will come from the factory with the following default settings:

- Freeze — “Terminals not jumped” on all the time
- Temp — 30 F
- Lockout — 2
- Reset — Y
- Alarm — PULSE
- Test — NO
- Dry Contact — Normally Open (NO)

SERVICE

Perform the procedures outlined below periodically, as indicated.

An annual “checkup” is recommended by a licensed refrigeration mechanic. Recording the performance measurements of volts, amps, and water temperature differences (both heating and cooling) is recommended. This data should be compared to the information on the unit’s data plate and the data taken at the original startup of the equipment.

Periodic lockouts almost always are caused by air or water flow problems. The lockout (shutdown) of the unit is a normal protective measure in the design of the equipment. If continual lockouts occur, call a mechanic immediately and have them check for: water flow problems, water temperature problems, air flow problems or air temperature problems. Use of the pressure and temperature charts for the unit may be required to properly determine the cause.

⚠ WARNING

To prevent injury or death due to electrical shock or contact with moving parts, open unit disconnect switch before servicing unit.

IMPORTANT: When a compressor is removed from this unit, system refrigerant circuit oil will remain in the compressor. To avoid leakage of compressor oil, the refrigerant lines of the compressor must be sealed after it is removed.

IMPORTANT: All refrigerant discharged from this unit must be recovered without exception. Technicians must follow industry accepted guidelines and all local, state and federal statutes for the recovery and disposal of refrigerants.

IMPORTANT: To avoid the release of refrigerant into the atmosphere, the refrigerant circuit of this unit must only be serviced by technicians who meet local, state and federal proficiency requirements.

Filters — Filter changes or cleanings are required at regular intervals. The time period between filter changes will depend upon the type of environment the equipment is used in. In a single family home that is not under construction, changing or cleaning the filter every 60 days may be sufficient. In other applications such as motels, where daily vacuuming produces a large amount of lint, filter changes may need to be as frequent as biweekly. See Fig. 1 and 2 for replacement filter sizes.

NOTE: Horizontal units containing two filters are taped together at the factory to facilitate removal. This should be done by end user as new filters are installed.

IMPORTANT: Units should never be operated without a filter.

Water Coil — Keep all air out of the water coil. Check open loop systems to be sure the well head is not allowing air to infiltrate the water line. Always keep lines airtight.

Inspect heat exchangers regularly, and clean more frequently if the unit is located in a “dirty” environment. Keep the heat exchanger full of water at all times. Open loop systems should have an inverted P trap placed in the discharge line to keep water in the heat exchanger during off cycles. Closed loop systems must have a minimum of 15 psig during the summer and 40 psig during the winter. Check P trap frequently for proper operation.

⚠ CAUTION

To avoid fouled machinery and extensive unit clean-up, DO NOT operate units without filters in place. DO NOT use equipment as a temporary heat source during construction.

Condensate Drain Pans — The condensate drain should be checked annually by cleaning and flushing to ensure proper drainage.

Check condensate drain pans for algae growth twice a year. If algae growth is apparent, consult a water treatment specialist for proper chemical treatment. Applying an algaecide every three months will typically eliminate algae problems in most locations.

Refrigerant System — Verify air and water flow rates are at proper levels before servicing. To maintain sealed circuitry integrity, do not install service gages unless unit operation appears abnormal.

Check to see that unit is within the superheat and subcooling temperature ranges. If the unit is not within these ranges, recover and reweigh in refrigerant charge.

Compressor — Conduct annual amperage checks to ensure that amp draw is no more than 10% greater than indicated on the serial plate data.

Fan Motors — All units have lubricated fan motors. Fan motors should never be lubricated unless obvious, dry operation is suspected. Periodic maintenance oiling is NOT recommended, as it will result in dirt accumulating in the excess oil and cause eventual motor failure. Conduct annual dry operation check and amperage check to ensure amp draw is no more than 10% greater than indicated on serial plate data.

Condensate Drain Cleaning — Clean the drain line and unit drain pan at the start of each cooling season. Check flow by pouring water into drain. Be sure trap is filled to maintain an air seal.

Air Coil Cleaning — Remove dirt and debris from evaporator coil as required by condition of the coil. Clean coil with a stiff brush, vacuum cleaner, or compressed air. Use a fin comb of the correct tooth spacing when straightening mashed or bent coil fins.

Condenser Cleaning — Water-cooled condensers may require cleaning of scale (water deposits) due to improperly maintained closed-loop water systems. Sludge build-up may need to be cleaned in an open water tower system due to induced contaminants.

Local water conditions may cause excessive fouling or pitting of tubes. Condenser tubes should therefore be cleaned at least once a year, or more often if the water is contaminated.

Proper water treatment can minimize tube fouling and pitting. If such conditions are anticipated, water treatment analysis is recommended. Refer to the Carrier System Design Manual, Part 5, for general water conditioning information.

CAUTION

Follow all safety codes. Wear safety glasses and rubber gloves when using inhibited hydrochloric acid solution. Observe and follow acid manufacturer's instructions.

Clean condensers with an inhibited hydrochloric acid solution. The acid can stain hands and clothing, damage concrete, and, without inhibitor, damage steel. Cover surroundings to guard against splashing. Vapors from vent pipe are not harmful, but take care to prevent liquid from being carried over by the gases.

Warm solution acts faster, but cold solution is just as effective if applied for a longer period.

GRAVITY FLOW METHOD — Do not add solution faster than vent can exhaust the generated gases.

When condenser is full, allow solution to remain overnight, then drain condenser and flush with clean water. Follow acid manufacturer's instructions. See Fig. 25.

FORCED CIRCULATION METHOD — Fully open vent pipe when filling condenser. The vent may be closed when condenser is full and pump is operating. See Fig. 26.

Regulate flow to condenser with a supply line valve. If pump is a non overloading type, the valve may be fully closed while pump is running.

For average scale deposit, allow solution to remain in condenser overnight. For heavy scale deposit, allow 24 hours. Drain condenser and flush with clean water. Follow acid manufacturer's instructions.

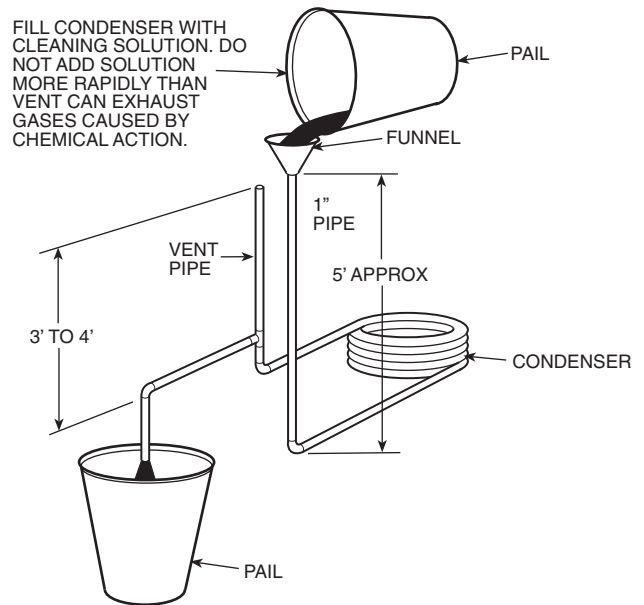

Fig. 25 — Gravity Flow Method

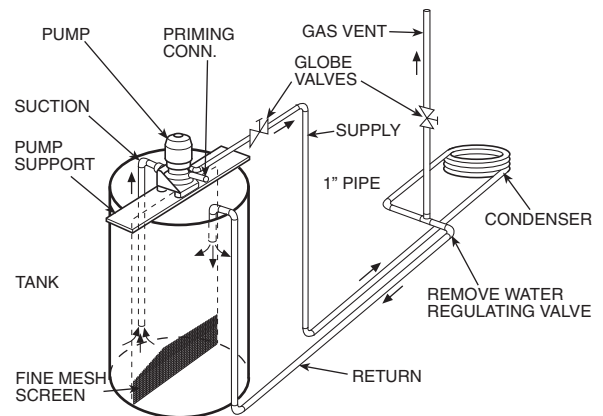

Fig. 26 — Forced Circulation Method

Checking System Charge — Units are shipped with full operating charge. If recharging is necessary:

1. Insert thermometer bulb in insulating rubber sleeve on liquid line near filter drier. Use a digital thermometer for all temperature measurements. DO NOT use a mercury or dial-type thermometer.
2. Connect pressure gage to discharge line near compressor.
3. After unit conditions have stabilized, read head pressure on discharge line gage.

NOTE: Operate unit a minimum of 15 minutes before checking charge.

4. From standard field-supplied Pressure-Temperature chart for R-410A, find equivalent saturated condensing temperature.
5. Read liquid line temperature on thermometer; then subtract from saturated condensing temperature. The difference equals subcooling temperature.
6. Compare the subcooling temperature with the normal temperature. If the measured liquid line temperature does not agree with the required liquid line temperature, ADD refrigerant to raise the temperature or REMOVE refrigerant (using standard practices) to lower the temperature (allow a tolerance of $\pm 3^\circ \text{F}$).

Refrigerant Charging

⚠ WARNING

To prevent personal injury, wear safety glasses and gloves when handling refrigerant. Do not overcharge system — this can cause compressor flooding.

NOTE: Do not vent or depressurize unit refrigerant to atmosphere. Remove and recover refrigerant following accepted practices.

Air Coil Fan Motor Removal

⚠ CAUTION

Before attempting to remove fan motors or motor mounts, place a piece of plywood over evaporator coils to prevent coil damage.

Disconnect motor power wires from motor terminals before motor is removed from unit.

1. Shut off unit main power supply.
2. Loosen bolts on mounting bracket and remove inlet ring.
3. Remove motor.

Slide motor/bracket assembly to extreme right and lift out through space between fan scroll and side frame. Rest motor on a high platform such as a step ladder. Do not allow motor to hang by its power wires.

TROUBLESHOOTING

When troubleshooting problems with a WSHP, consider the following:

Control Sensors — The control system employs 2 nominal 10,000 ohm thermistors (FP1 and FP2) that are used for freeze protection. Be sure FP1 is located in the discharge fluid and FP2 is located in the air discharge. See Fig. 27.

Thermistor — A thermistor may be required for single-phase units where starting the unit is a problem due to low voltage. See Fig. 28 for thermistor nominal resistance.

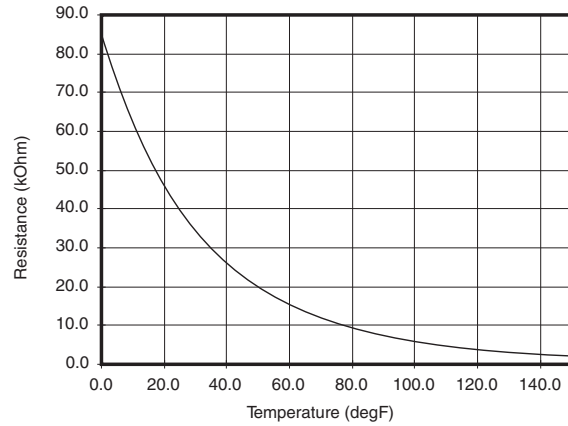

Fig. 28 — Thermistor Nominal Resistance

Thermostatic Expansion Valves — Thermostatic expansion valves (TXV) are used as a means of metering the refrigerant through the evaporator to achieve a preset superheat at the TXV sensing bulb. Correct superheat of the refrigerant is important for the most efficient operation of the unit and for the life of the compressor.

Packaged heat pumps typically use one bi-flow TXV to meter refrigerant in both modes of operation. When diagnosing possible TXV problems it may be helpful to reverse the refrigerant flow to assist with the diagnosis.

Geothermal and water source heat pumps are designed to operate through a wide range of entering water temperatures that will have a direct effect on the unit refrigerant operating pressures. Therefore, diagnosing TXV problems can be difficult.

TXV FAILURE — The most common failure mode of a TXV is when the valve fails while closed. Typically, a TXV uses spring pressure to close the valve and an opposing pressure, usually from a diaphragm, to open the valve. The amount of pressure exerted by the diaphragm will vary, depending on the pressure inside of the sensing bulb. As the temperature of and pressure within the bulb decreases, the valve will modulate closed and restrict the refrigerant flow through the valve. The result is less refrigerant in the evaporator and an increase in the superheat. As the temperature at the bulb increases, the diaphragm pressure will increase, which opens the valve and allows more refrigerant flow and a reduction in the superheat.

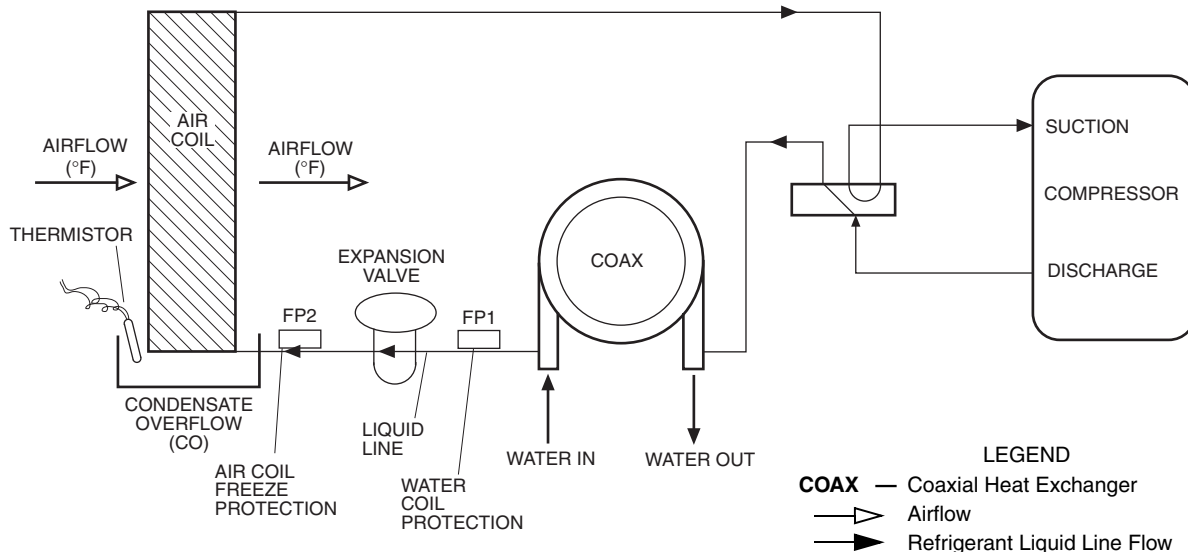

Fig. 27 — FP1 and FP2 Thermistor Location

If the sensing bulb, connecting capillary, or diaphragm assembly are damaged, pressure is lost and the spring will force the valve to a closed position. Often, the TXV will not close completely so some refrigerant flow will remain, even if inadequate flow for the heat pump to operate.

The TXV sensing bulb must be properly located, secured, and insulated as it will attempt to control the temperature of the line to which it is connected. The sensing bulb must be located on a dedicated suction line close to the compressor. On a packaged heat pump, the bulb may be located almost any place on the tube running from the compressor suction inlet to the reversing valve. If the bulb is located on a horizontal section, it should be placed in the 10:00 or 2:00 position for optimal performance.

CAUTION

Use caution when tightening the strap. The strap must be tight enough to hold the bulb securely but caution must be taken not to over-tighten the strap, which could dent, bend, collapse or otherwise damage the bulb.

The bulb must be secured to the pipe using a copper strap. The use of heat transfer paste between the bulb and the pipe will also help ensure optimum performance.

The bulb must also be properly insulated to eliminate any influence on valve operation by the surrounding conditions. Cork tape is the recommended insulation as it can be molded tight to the bulb to prevent air infiltration.

Causes of TXV Failure — The most common causes of TXV failure are:

1. A cracked, broken, or damaged sensing bulb or capillary can be caused by excessive vibration of the capillary during shipping or unit operation.

If the sensing bulb is damaged or if the capillary is cracked or broken, the valve will be considered failed and must be replaced. Replacement of the TXV “power head” or sensing bulb, capillary, diaphragm assembly is possible on some TXVs. The power head assembly screws onto most valves, but not all are intended to be replaceable. If the assembly is not replaceable, replace the entire valve.

2. Particulate debris within the system can be caused by several sources including contaminated components, tubing, and service tools, or improper techniques used during brazing operations and component replacement.

Problems associated with particulate debris can be compounded by refrigerant systems that use POE (polyol ester oil). POE oil has solvent-like properties that will clean the interior surfaces of tubing and components. Particulates can be released from interior surfaces and may migrate to the TXV strainer, which can lead to plugging of the strainer.

3. Corrosive debris within the system may happen after a failure, such as a compressor burn out, if system was not properly cleaned.
4. Noncondensables may be present in the system. Noncondensables includes any substance other than the refrigerant or oil such as air, nitrogen, or water. Contamination can be the result of improper service techniques, use of contaminated components, and/or improper evacuation of the system.

Symptoms — The symptoms of a failed TXV can be varied and will include one or more of the following:

- Low refrigerant suction pressure
- High refrigerant superheat
- High refrigerant subcooling
- TXV and/or low pressure tubing frosting

- Equalizer line condensing and at a lower temperature than the suction line or the equalizer line frosting
- FP1 faults in the heating mode in combination with any of the symptoms listed above
- FP2 faults in the cooling mode in combination with any of the symptoms listed above. Some symptoms can mimic a failed TXV but may actually be caused by another problem.

Before conducting an analysis for a failed TXV the following must be verified:

- Confirm that there is proper water flow and water temperature in the heating mode.
- Confirm that there is proper airflow and temperature in the cooling mode.
- Ensure coaxial water coil is clean on the inside; this applies to the heating mode and may require a scale check.
- Refrigerant may be undercharged. To verify, subcooling and superheat calculations may be required.

Diagnostics—Several tests may be required to determine if a TXV has failed. The following tools may be required for testing:

1. Refrigerant gage manifold compatible with the refrigerant in the system.
2. Digital thermometer, preferably insulated, with wire leads that can be connected directly to the tubing.
3. Refrigerant pressure-temperature chart for the refrigerant used.

To determine that a TXV has failed, verify the following:

- The suction pressure is low and the valve is non-responsive.
The TXV sensing bulb can be removed from the suction line and warmed by holding the bulb in your hand. This action should result in an increase in the suction pressure while the compressor is operating. The sensing bulb can also be chilled by immersion in ice water, which should result in a decrease in the suction pressure while the compressor is operating. No change in the suction pressure would indicate a nonresponsive valve.
- Simultaneous LOW suction pressure, HIGH refrigerant subcooling and HIGH superheat may indicate a failed valve.
- LOW suction pressure, LOW subcooling and HIGH superheat may indicate an undercharge of refrigerant. HIGH subcooling and LOW superheat may indicate an overcharge of refrigerant. The suction pressure will usually be normal or high if there is an overcharge of refrigerant.
- LOW suction pressure and frosting of the valve and/or equalizer line may indicate a failed valve. However, these symptoms may also indicate an undercharge of refrigerant. Calculate the subcooling and superheat to verify a failed valve or refrigerant charge issue.

Repair

WARNING

Puron® refrigerant (R-410A) operates at higher pressure than R-22, which is found in other WSHPs. Tools such as manifold gages must be rated to withstand the higher pressures. Failure to use approved tools may result in a failure of tools, which can lead to severe damage to the unit, injury or death.

⚠ WARNING

Most TXVs are designed for a fixed superheat setting and are therefore considered non-adjustable. Removal of the bottom cap will not provide access for adjustment and can lead to damage to the valve or equipment, unintended venting of refrigerant, personal injury, or possibly death.

⚠ CAUTION

Use caution when tightening the strap. The strap must be tight enough to hold the bulb securely but caution must be taken not to over-tighten the strap, which could dent, bend, collapse or otherwise damage the bulb.

⚠ CAUTION

Puron refrigerant (R-410A) requires the use of synthetic lubricant (POE oil). Do not use common tools on systems that contain R-22 refrigerants or mineral oil. Contamination and failure of this equipment may result.

IMPORTANT: Always recover the refrigerant from the system with suitable approved tools, recovery equipment, and practices prior to attempting to remove or repair any TXV.

IMPORTANT: Due to the hygroscopic nature of the POE oil in Puron refrigerant (R-410A) and other environmentally balanced refrigerants, any component replacement must be conducted in a timely manner using caution and proper service procedure for these types of refrigerants. A complete installation instruction will be included with each replacement TXV/filter drier assembly. It is of critical importance these instructions are carefully understood and followed. Failure to follow these instructions can result in a system that is contaminated with moisture to the extent that several filter drier replacements may be required to properly dry the system.

IMPORTANT: Repair of any sealed refrigerant system requires training in the use of refrigeration tools and procedures. Repair should only be attempted by a qualified service technician. A universal refrigerant handling certificate will be required. Local and/or state license or certificate may also be required.

⚠ CAUTION

Disconnect power from unit before removing or replacing connectors, or servicing motor. Wait 5 minutes after disconnecting power before opening motor.

Moisture Check — To perform moisture check:

- Check that connectors are orientated “down” (or as recommended by equipment manufacturer).
- Arrange harnesses with “drip loop” under motor.
- Check if condensate drain is plugged.
- Check for low airflow (too much latent capacity).
- Check for undercharged condition.
- Check and plug leaks in return ducts, cabinet.

Table 11 — Good Practices

DO	DO NOT
Check motor, controls wiring, and connections thoroughly before replacing motor.	Automatically assume the motor is bad.
Orient connectors down so water cannot get in. Install “drip loops.”	Locate connectors above 7 and 4 o'clock positions.
Use authorized motor and control model numbers for replacement.	Replace one motor or control model number with another (unless replacement is authorized).
Keep static pressure to a minimum by: <ul style="list-style-type: none"> • Using high efficiency, low-static filters. • Keeping filters clean. • Designing ductwork for minimum static and maximum comfort. • Improving ductwork when replacement is necessary. 	Use high pressure drop filters. Use restricted returns.
Size equipment wisely.	Oversize system then compensate with low airflow.
Check orientation before inserting motor connectors.	Plug in power connector backwards. Force plugs.

Table 12 — Troubleshooting

FAULT	POSSIBLE CAUSE	SOLUTION
Entire unit does not run	Power Supply Off	Apply power, close disconnect.
	Blown Fuse	Replace fuse or reset circuit breaker. Check for correct fuses.
	Voltage Supply Low	If voltage is below minimum voltage specified on unit data plate, contact local power company.
	Thermostat	Set the fan to ON, the fan should run. Set thermostat to COOL and lowest temperature setting, the unit should run in the cooling mode (reversing valve energized). Set unit to HEAT and the highest temperature setting, the unit should run in the heating mode (reversing valve deenergized). If neither the blower or compressor run in all three cases, the thermostat could be miswired or faulty. To ensure miswired or faulty thermostat verify that 24 volts is available at the low voltage terminal strip between "R" and "C", "Y" and "C", and "O" and "C". If the blower does not operate, verify 24 volts between terminals "G" and "C". Replace the thermostat if defective.
Blower operates but compressor does not	Thermostat	Check setting, calibration, and wiring.
	Wiring	Check for loose or broken wires at compressor, capacitor, or contactor.
	Safety Controls	Check C board red default LED for blink code.
	Compressor overload open	If the compressor is cool and the overload will not reset, replace compressor.
	Compressor motor grounded	Internal winding grounded to the compressor shell. Replace compressor.
	Compressor windings Open	After compressor has cooled, check continuity of the compressor windings. If the windings are open, replace the compressor.
Unit off on high pressure control	Discharge pressure too high	In "COOLING" mode: Lack of or inadequate water flow. Entering water temperature is too warm. Scaled or plugged condenser. In "HEATING" mode: Lack of or inadequate air flow. Blower inoperative, clogged filter or restrictions in duct work
	Refrigerant charge	The unit is overcharged with refrigerant. Reclaim refrigerant, evacuate and recharge with factor recommended charge.
	High pressure	Check for defective or improperly calibrated high pressure switch.
Unit off on low pressure control	Suction pressure too low	In "COOLING" mode: Lack of or inadequate air flow. Entering air temperature is too cold. Blower inoperative, clogged filter or restrictions in duct work In "HEATING" mode: Lack of or inadequate water flow. Entering water temperature is too cold. Scaled or plugged condenser.
	Refrigerant charge	The unit is low on refrigerant. Check for refrigerant leak, repair, evacuate and recharge with factory recommended charge.
	Low pressure switch	Check for defective or improperly calibrated low pressure switch.
Unit short cycles	Unit oversized	Recalculate heating and or cooling loads.
	Thermostat	Thermostat installed near a supply air grill; relocate thermostat. Readjust heat anticipator.
	Wiring and controls	Check for defective or improperly calibrated low pressure switch.
Insufficient cooling or heating	Unit undersized	Recalculate heating and or cooling loads. If excessive, possibly adding insulation and shading will rectify the problem.
	Loss of conditioned air by leakage	Check for leaks in duct work or introduction of ambient air through doors or windows.
	Airflow	Lack of adequate air flow or improper distribution of air. Replace dirty filter.
	Refrigerant charge	Low on refrigerant charge causing inefficient operation.
	Compressor	Check for defective compressor. If discharge is too low and suction pressure is too high, compressor is not pumping properly. Replace compressor.
	Reversing Valve	Defective reversing valve creating bypass of refrigerant from discharge of suction side of compressor. Replace reversing valve.
	Operating pressures	Compare unit operation pressures to the pressure/temperature chart for the unit.
	TXV	Check TXV for possible restriction or defect. Replace if necessary.
Control board trouble shooting	Compressor will not run, no fault blink code	<pre> graph TD Q1[Is Green Power LED light on and no Red Blink Code?] -- No --> A1[- Check all power supplies - Check all safety switches] Q1 -- Yes --> Q2[Is there power to the "Y" Call (C-Y)?] Q2 -- No --> A2[Check thermostat settings and configurations for heat pumps, and wiring] Q2 -- Yes --> Q3[Is there 24 V power from C to CC?] Q3 -- No --> A3[Check for Red Blink Code. If Red Blink Code is not present, replace UPM Board] Q3 -- Yes --> A4[UPM Board is Good] </pre>

**50PSH.PSV
START-UP CHECKLIST**

CUSTOMER: _____ JOB NAME: _____
MODEL NO.: _____ SERIAL NO.: _____ DATE: _____

I. PRE-START-UP

- DOES THE UNIT VOLTAGE CORRESPOND WITH THE SUPPLY VOLTAGE AVAILABLE? (Y/N) _____
- HAVE THE POWER AND CONTROL WIRING CONNECTIONS BEEN MADE AND TERMINALS TIGHT? (Y/N) _____
- HAVE WATER CONNECTIONS BEEN MADE AND IS FLUID AVAILABLE AT HEAT EXCHANGER? (Y/N) _____
- HAS PUMP BEEN TURNED ON AND ARE ISOLATION VALVES OPEN? (Y/N) _____
- HAS CONDENSATE CONNECTION BEEN MADE AND IS A TRAP INSTALLED? (Y/N) _____
- IS AN AIR FILTER INSTALLED? (Y/N) _____

II. START-UP

- IS FAN OPERATING WHEN COMPRESSOR OPERATES? (Y/N) _____
- IF 3-PHASE SCROLL COMPRESSOR IS PRESENT, VERIFY PROPER ROTATION PER INSTRUCTIONS. (Y/N) _____

UNIT VOLTAGE — COOLING OPERATION

PHASE AB VOLTS _____ PHASE BC VOLTS _____ PHASE CA VOLTS _____
(if 3 phase) (if 3 phase)
PHASE AB AMPS _____ PHASE BC AMPS _____ PHASE CA AMPS _____
(if 3 phase) (if 3 phase)

CONTROL VOLTAGE

- IS CONTROL VOLTAGE ABOVE 21.6 VOLTS? (Y/N) _____.
- IF NOT, CHECK FOR PROPER TRANSFORMER CONNECTION.

TEMPERATURES

FILL IN THE ANALYSIS CHART ATTACHED.

COAXIAL HEAT EXCHANGER	COOLING CYCLE:	FLUID IN	_____ F	FLUID OUT	_____ F	_____ PSI	_____ FLOW
	HEATING CYCLE:	FLUID IN	_____ F	FLUID OUT	_____ F	_____ PSI	_____ FLOW
AIR COIL	COOLING CYCLE:	AIR IN	_____ F	AIR OUT	_____ F		
	HEATING CYCLE:	AIR IN	_____ F	AIR OUT	_____ F		

HEATING CYCLE ANALYSIS

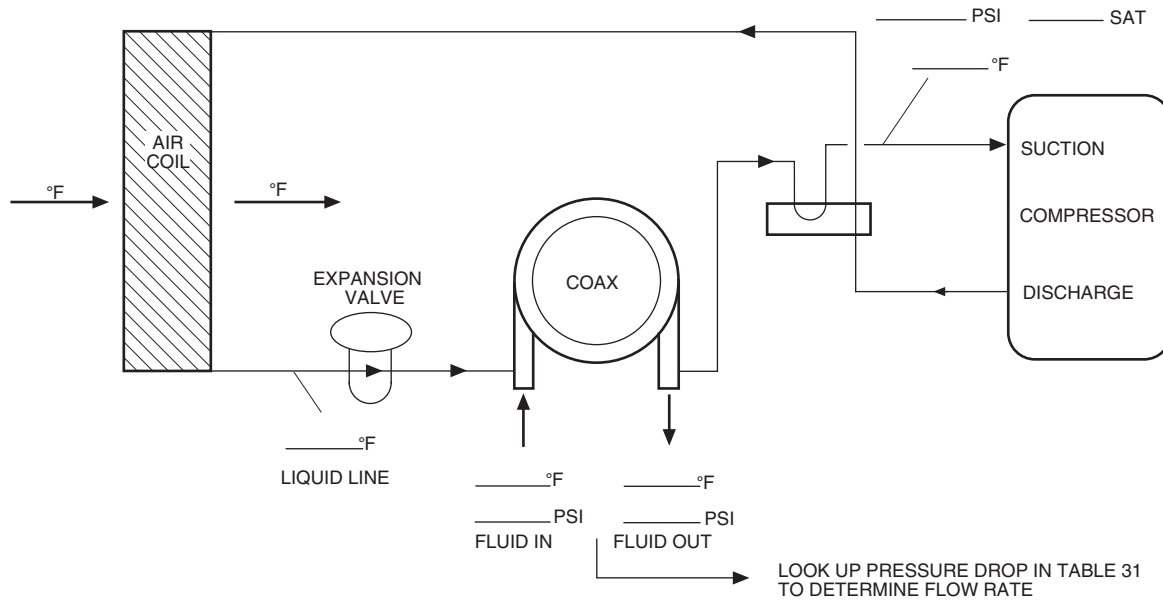

COOLING CYCLE ANALYSIS

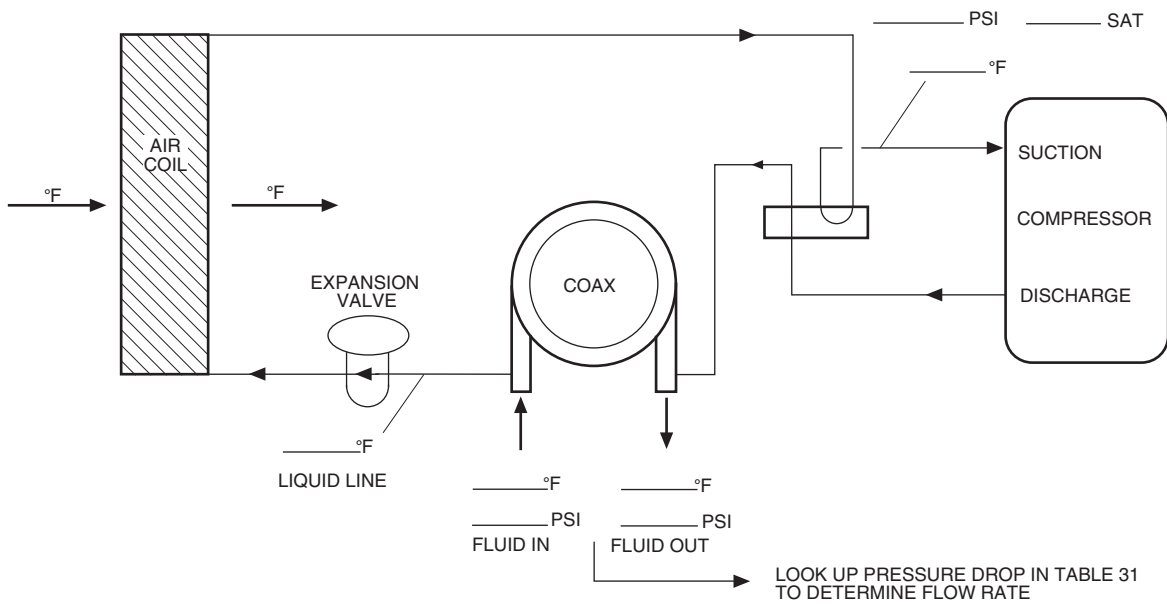

HEAT OF EXTRACTION (ABSORPTION) OR HEAT OF REJECTION =

$$\frac{\text{FLOW RATE (GPM)}}{\text{(Btu/hr)}} \times \text{TEMP. DIFF. (DEG. F)} \times \text{FLUID FACTOR}^* =$$

$$\text{SUPERHEAT} = \text{SUCTION TEMPERATURE} - \text{SUCTION SATURATION TEMPERATURE}$$

$$= \text{ (DEG F)}$$

$$\text{SUBCOOLING} = \text{DISCHARGE SATURATION TEMPERATURE} - \text{LIQUID LINE TEMPERATURE}$$

$$= \text{ (DEG F)}$$

*Use 500 for water, 485 for antifreeze.

CUT ALONG DOTTED LINE