

Omega **ENERZONE Legacy Series** are a direct replacement for Enerzone electromechanical control units. These units feature state of the art components such as microprocessor based controls, R410a refrigerant and dimensions that match the original Enerzone units. This provides contractors with a simple “drop-in” replacement unit with the added feature of modern microprocessor control capabilities.

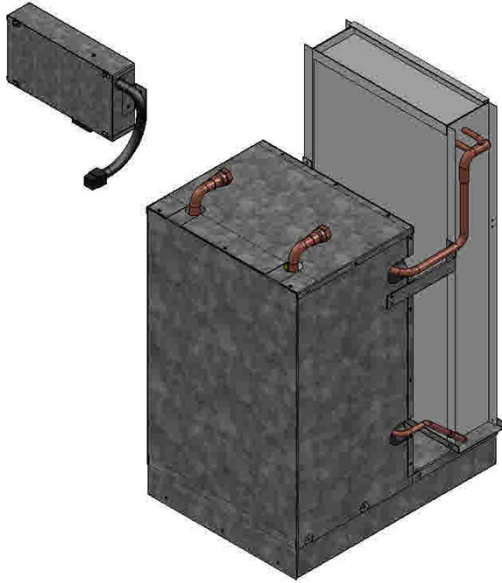

FEATURES

- Omega ENERZONE Legacy unit is a modern heat pump. Each unit comes with R410A refrigerant and is fully factory tested before shipment. Omega is pleased to offer a 1 year parts warranty and an optional 5 year compressor warranty on all units, from time of shipment.
- Omega units come standard with a microelectronic Legacy control box that easily replaces the existing electromechanical chassis control. Controls and relays are mounted on a single printed circuit board with factory wiring to connection plugs. This direct digital control board is designed to provide control of the entire unit as well as outputs for unit status and fault detection.
- Each unit also comes complete with low pressure and high pressure sensors. Factory installed logic makes sure the unit operates safely and will take the unit offline in case of malfunction or dangerous operation. Intelligent microprocessor based control continuously monitors operation of the unit and attempts to keep the unit online during difficult start-ups (ie. lower temperature start-ups).

STANDARD FEATURES

- Quiet, high efficiency R410A compressors are available for all units. Units up to 1-1/2 Ton use a rotary compressor. Units 2 tons and above utilize scroll compressors. All compressors come with overload protection.
- Thermal Expansion Valve (TEV) for refrigerant metering is used on all units to ensure accurate refrigerant flow through the unit.
- Water coil freeze protection is offered on all units through direct refrigeration control. Internal logic of the board also minimizes nuisance trip outs.
- Casing is manufactured from heavy gauge galvanized steel.

OPTIONAL FEATURES

- Hose kits in 24” lengths are available for installation to existing units.
- Auto flow valves can be factory installed to ensure proper water flow to the unit is maintained. Auto flow valves require a differential pressure between 2 and 80psi to operate correctly and maintain the desired water flow.
- An auto shut off valve is available to disable water flow through the unit when there is no call for the compressor. This provides an opportunity to save system pump energy when the compressor unit is off.
- A geothermal option is available for low temperature applications. Contact your representative for details.
- Return air filters are available for installation.

EASY INSTALLATION

Installations are made easy by simply removing the existing unit and replacing it with a new Omega Legacy and control box unit. This allows for minimal installation time for contractors.

- Dimensionally the units are identical to existing units. Supply, return and condensate connections are designed to line up with the existing water connections.
- Electrical power is designed to be accepted into an electrical box to improve the safety of existing installations.
- The Legacy control box provide a simple interface to the existing controls.

Dimensional Data

MODEL	CAPACITY	A	B	C	D	E	F	Outlet	Inlet
	Nominal Tonnage	in	in	in	in	in	in		
HRP-030	3/4	11 1/8	22 1/16	15.00	11 1/2	15.00	21 1/16	1/2 NPT	1/2 NPT
HRP-040	1	11 1/8	22 1/16	15.00	11 1/2	15.00	21 1/16	1/2 NPT	1/2 NPT
HRP-060	1 1/2	13 3/16	22 1/4	18.00	14.00	17 7/8	28 3/32	1/2 NPT	1/2 NPT
HRP-080	2	17 1/8	23 5/16	22 3/16	18.00	22.00	29 1/8	3/4 NPT	3/4 NPT
HRP-100	2 1/2	17 1/8	23 5/16	22 3/16	18.00	22.00	29 1/8	3/4 NPT	3/4 NPT

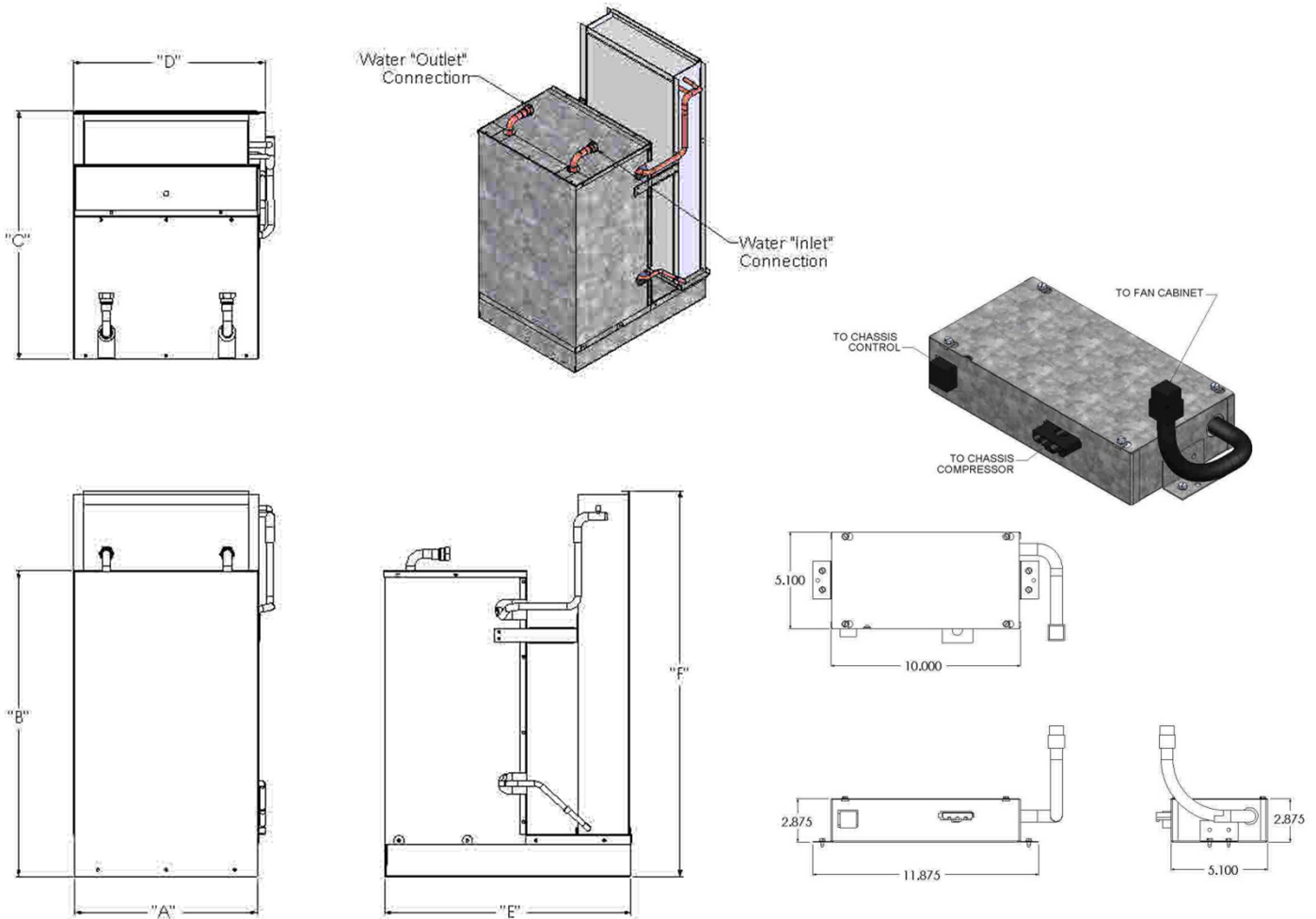

Performance Data

MODEL	REFRIG	WATER FLOW	AIR FLOW	WATER DROP	COOLING				HEATING		
					GPM	CFM	BTUH	WATT	COP	EER	BTUH
HRP-030	R410	3.00	310	6'	9873	796	3.63	12.60	14100	944	4.37
HRP-040	R410	3.13	475	7'	13010	1000	3.81	13.26	16600	1114	4.37
HRP-060	R410	4.60	600	14'	17600	1455	3.59	12.10	22600	1577	4.20
HRP-080	R410	6.72	817	15'	23952	1766	3.98	13.56	30415	1964	4.54
HRP-100	R410	6.50	1006	15'	28326	2314	3.59	12.24	36501	2505	4.27