

ELEVATION™ X 36 DIRECT VENT GAS FIREPLACE



Specifications

Model	BTU	Width		Height		Depth		Glass Size
		Actual	Framing	Actual	Framing	Actual	Framing	
EX36NTEL	37,000	38 3/4"	39 3/4"	44"	43 3/4"	22"	22 1/4"	27" x 32 1/4"
EX36PTEL	34,000							

Dimensions

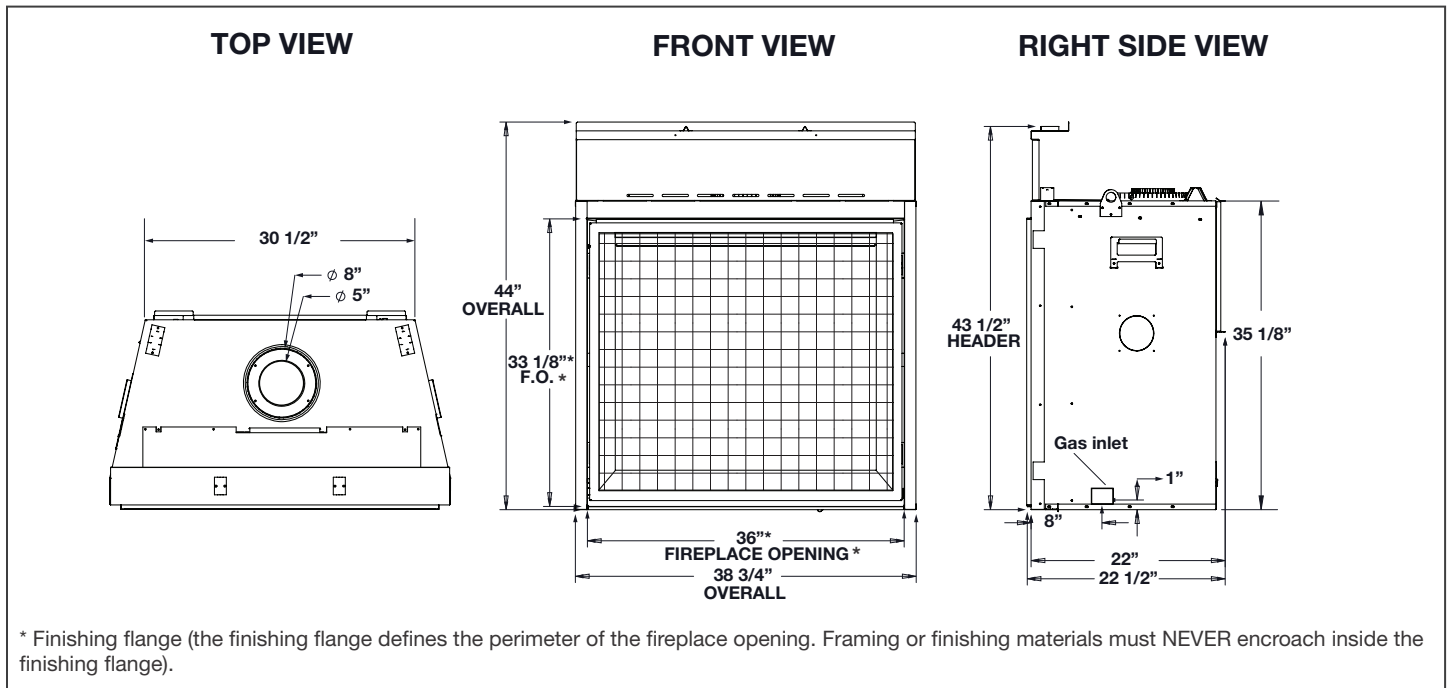

Appliance Location

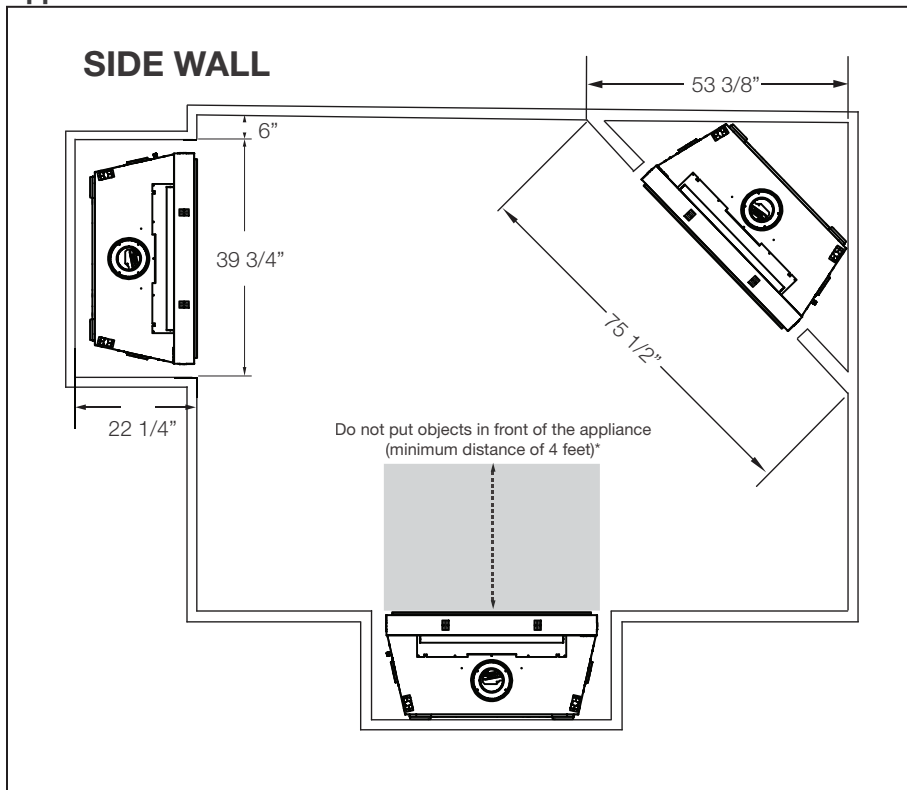

Combustible Mantel Clearances

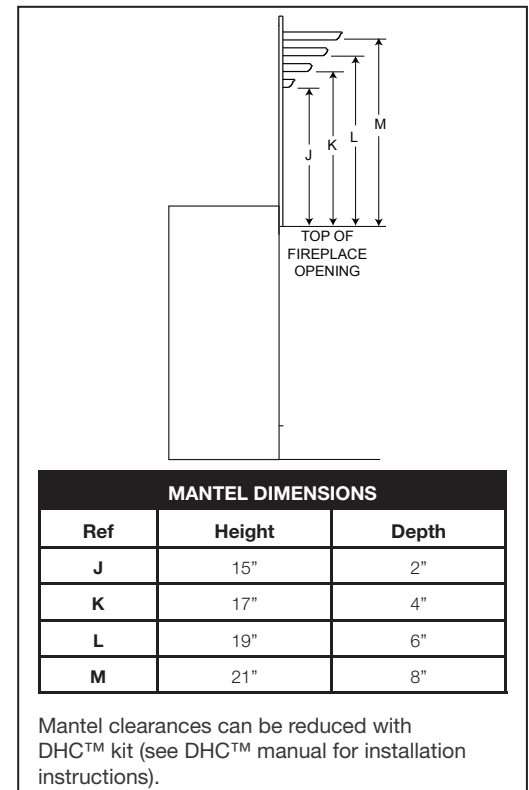

W415-2776 / 10.02.19

ELEVATION™ X 36 DIRECT VENT GAS FIREPLACE



Product information provided is not complete and is subject to change without notice. Please consult the installation manual for the most up to date installation information.

Wall Penetration

note:
Vent Sections
 When passing through a wall, use firestop spacer W010-1800 (supplied).
 When passing through a ceiling, use firestop spacer W500-0028 (not supplied).

Horizontal vent sections: A minimum clearance of 3" (76mm) on the top of the vent to combustibles and 2" (51mm) on the sides and bottom of the vent to combustibles is required.

Vertical vent sections: A minimum clearance of 1" (25mm) all around the vent pipe on all vertical runs to combustibles is required.

Framing

Flush Finish Framing

Recessed Finish Framing

* Recess frame can be "backed" with 3/4" ply to support TV mounting hardware.

FOYER À GAZ VENTILÉ DIRECTE ÉLÉVATION^{MD} X 36



Spécifications

Modèle	BTU	Largeur		Hauteur		Profondeur		Taille de verre
		Réel	Ossature	Réel	Ossature	Réel	Ossature	
EX36NTEL	37,000	38 3/4"	39 3/4"	44"	43 3/4"	22"	22 1/4"	27" x 32 1/4"
EX36PTEL	34,000							

Dimensions

VUE DE FACE

VUE DE CÔTÉ DROIT

VUE DE DESSUS

* La bride de finition (la bride de finition définit le périmètre de l'ouverture de l'appareil. Les matériaux d'ossature ou de finition NE JAMAIS empiètent à l'intérieur de la bride de finition).

Emplacement de l'Appareil

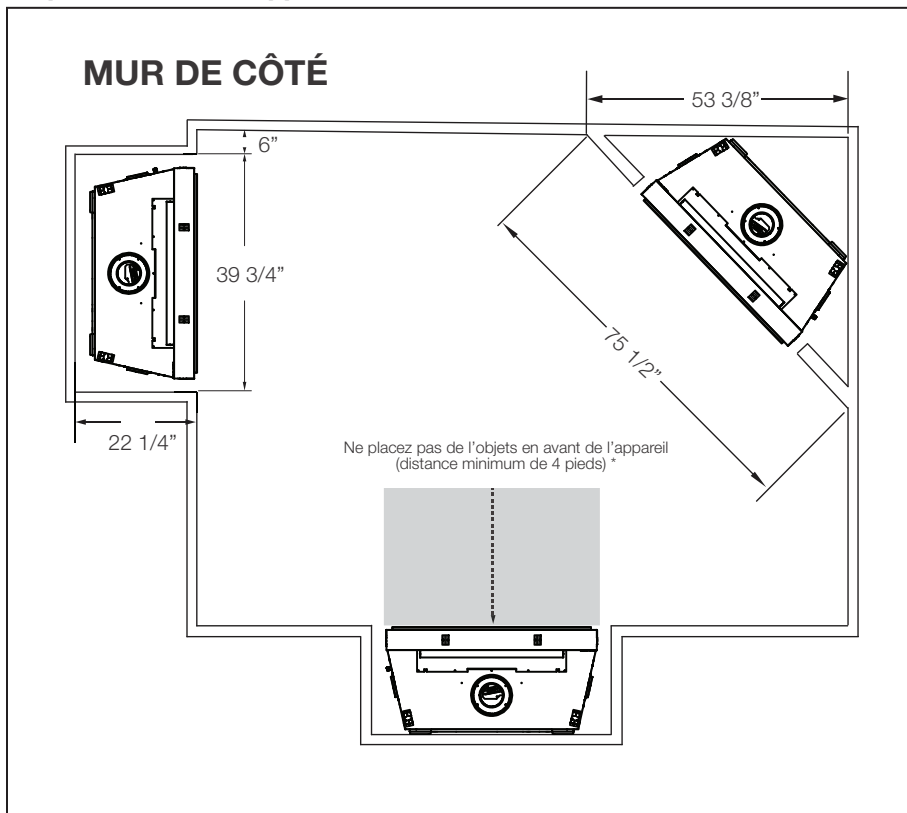

Dégagements Combustible de la Tablette

DESSUS DE L'OUVERTURE DE L'APPAREIL

DIMENSIONS DE LA TABLETTE		
Réf	Hauteur	Profondeur
J	15"	2"
K	17"	4"
L	19"	6"
M	21"	8"

Les dégagements de la tablette peuvent être réduits avec le kit DHCTM (voir le manuel DHCTM pour les instructions d'installation).

W415-2776 / 10.02.19

L'information du produit fourni n'est pas complet et est sujet de changer sans préavis. Consultez le manuel d'installation pour information d'installation actuel.

Pénétration du Mur

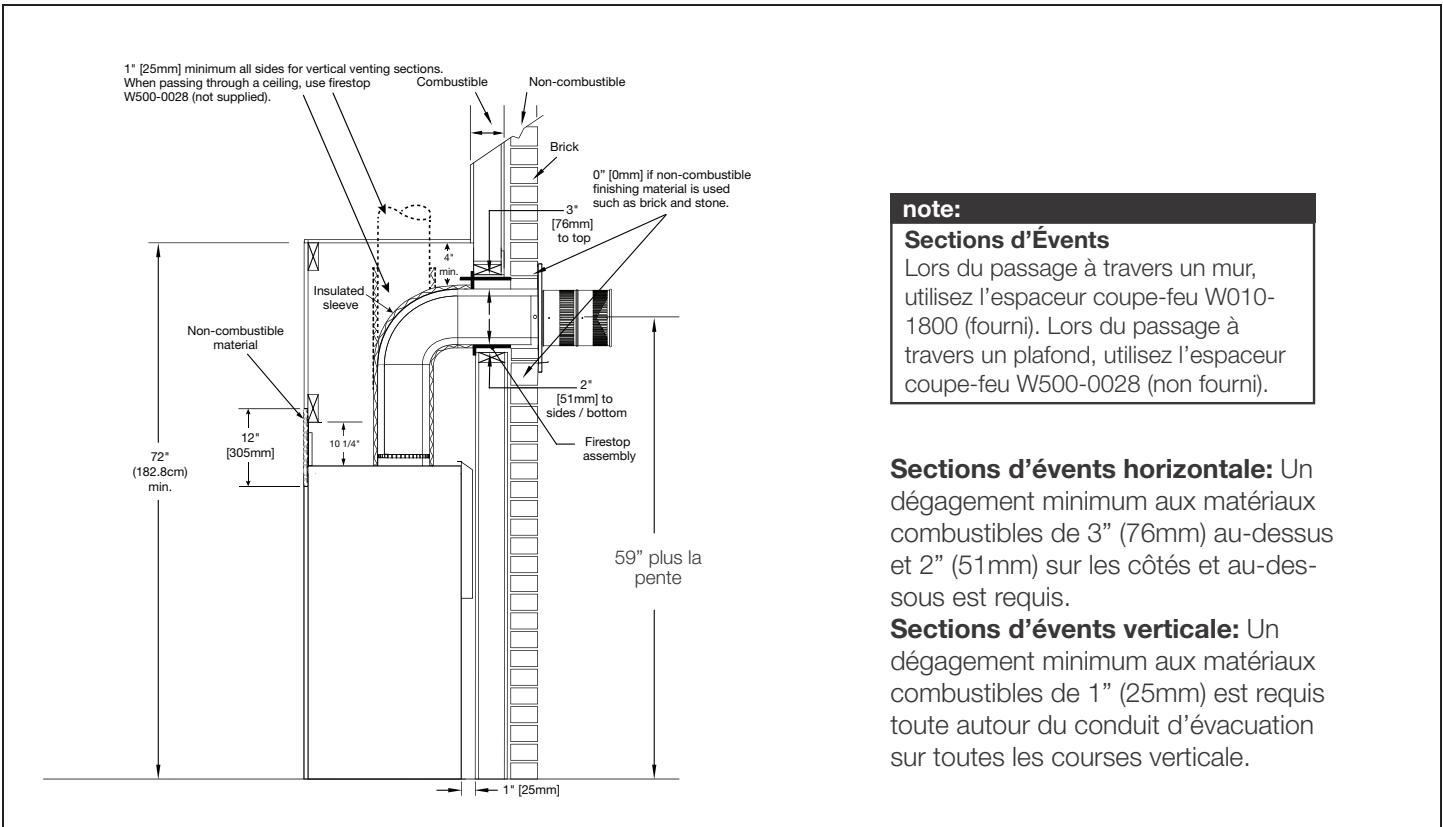

Ossature Fini - Affleuré et Encastré

